

**9. DECKS AND DECK SYSTEMS**

Reinforced concrete decks on girders are the predominant type of deck used on highway bridges in Minnesota. The deck is the structural element that transfers vehicle and pedestrian loads to the girders. It is analyzed as a continuous beam with the girders acting as supports. The top and bottom primary moment resisting reinforcement runs transversely in the deck. The concrete stool between the girder top flange and the deck bottom varies to allow placement of the deck to the proper elevation.

Only reinforced concrete decks supported on girders are covered in this section. Practices for slab type bridges, where the superstructure does not contain girder supports, are located in Article 5.3 of this manual.

Timber decks may be used on secondary roads and temporary bridges as part of the superstructure. Guidance for the design of timber decks is provided in Section 8.

Specialized deck systems are used for railroad bridges. A common design is a thru-girder system with floor beams supporting a bent plate. This channel shaped bent plate holds the ballast on which the rails are supported. These specialized deck systems are not currently covered in this manual.

**9.1 General**

**Bridge Deck Protection Policy**

Refer to BDM Article 2.4.1.1.2 for the bridge deck protection policy.

**9.1.1 Deck Drainage**

**Deck Drainage Considerations**

The design of a deck requires:

- Removing water from the driving surface using a crown cross-section to protect against potential hydroplaning.
- Channeling drainage water away from the bridge and features below the bridge using road grades and end slopes respectively.

Deck drains and drainage systems on bridges are strongly discouraged due to their high maintenance requirements. Debris tends to build up in the drains, causing plugging of the system. Drainage systems are also prone to leakage, which is especially a problem for box type structures where the system runs inside the box. Bridges with lengths less than 500 feet that are located over lakes or streams can usually be designed such that deck drains are not necessary. Bridges that are longer than 500 feet may have problems with deck flooding in severe rainstorms, and may require deck drains. The Bridge Waterways Unit will work with the Bridge Preliminary

Plans Unit to investigate the need for deck drains and include the requirements, if any, in the Preliminary Bridge Plan.

### **Superstructure Drains**

When drainage systems are required on bridges, avoid direct runoff into "waters of the state", as defined in *Mn. Statute 115.01, Subdivision 22*.

Extend drains a minimum of 1 inch below the bottom of superstructure. Use a longer extension (up to 1 foot maximum), if possible, where geometry below allows. See Standard Bridge Detail B701, B702, B705, or B706.

Avoid drain outlets over roadways, shoulders, sidewalks/trails, streams, railroad tracks, and end slopes. Drains placed over riprap require the area to be grouted, or a grouted flume section provided. At down spouts or deck drains, provide splash blocks.

Avoid drainage details that include flat elements (grades less than 5%). Pipes and drainage elements with flat profiles tend to collect debris and plug.

Note that special drainage requirements are necessary for bridges where a Corps of Engineers "404 permit" is required. The Bridge Waterways Unit may also require the addition of containment and treatment features to the project for bridges located in or near scenic waterways or near public water supply sources.

Provide the materials and gages for corrugated metal (C.M.) drains and semi-circle deck drains, such as those used on railroad bridges, in the plan details.

## **9.2 Concrete Deck on Beams**

Figure 9.2.1 illustrates the two most common concrete deck systems used. See the deck protection policy in BDM Article 2.4.1.1.2 for determination of which deck system to use for a given bridge project. The upper portion of the figure shows a monolithic deck constructed with a single concrete pour. The lower portion illustrates a deck with a wearing course.

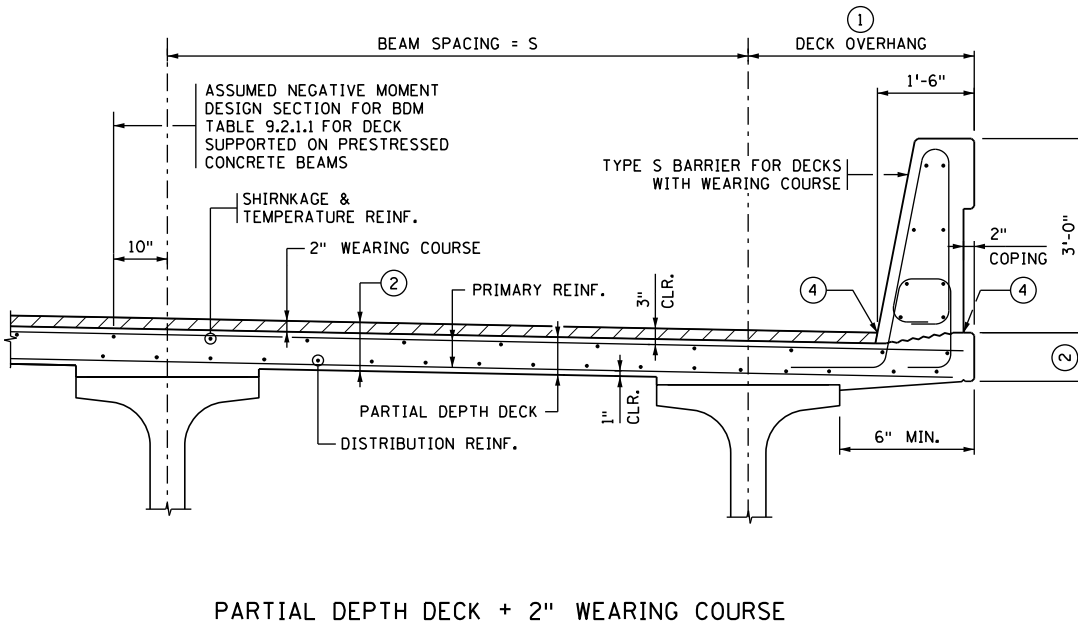
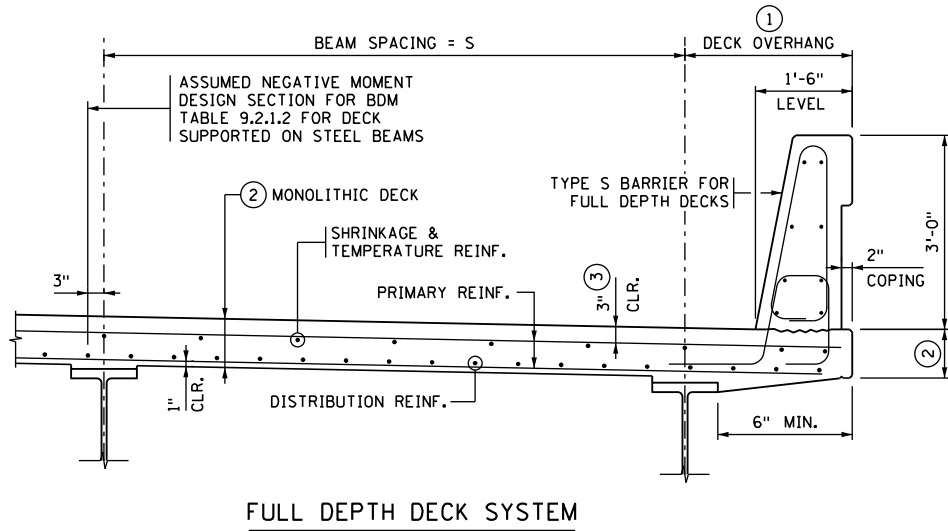

**GEOMETRY AND DESIGN ASSUMPTIONS FOR MOST COMMON CONCRETE DECK SYSTEMS**

**NOTES:**

EITHER DECK SYSTEM CAN BE USED WITH EITHER BEAM TYPE.  
 REINFORCEMENT CLEAR COVER SHOWN IS FOR EPOXY COATED STEEL BARS. COVER MAY DIFFER FOR STAINLESS OR GFRP BARS.

- ① PER BDM ARTICLE 2.4.1.1.1 GENERALLY LIMIT THE OVERHANG TO THE SMALLEST OF:
  - BEAM DEPTH
  - 40% OF BEAM SPACING
  - DECK COPING WIDTH + BARRIER WIDTH + 1'-0" + 1/2 FLANGE WIDTH
- ② FOR VEHICULAR BRIDGES, REQ'D. DECK THICKNESS AND EDGE OF DECK THICKNESS IS DEPENDENT ON BEAM SPACING (SEE TABLES 9.2.1.1 & 9.2.1.2). FOR PEDESTRIAN BRIDGES, USE 7" DECK THICKNESS WITH NO WEARING COURSE.
- ③ FOR PEDESTRIAN BRIDGES, PROVIDE 2" CLEAR COVER.
- ④ GUTTER LINE AND COPING ELEVATION TO MATCH.

**Figure 9.2.1**

**9.2.1 Deck Design  
and Detailing****Design**

The default reinforcement bar type used in concrete bridge decks is an epoxy coated bar with a yield strength,  $F_y$ , equal to 60 ksi which meets the material requirements of ASTM A615.

In special cases, as outlined in Technical Memorandum No. 17-02-B-01, use stainless steel reinforcement and design accordingly. Note that stainless steel bars have a higher yield strength and different clear cover requirements.

Use of glass fiber reinforced polymer (GFRP) reinforcement bars has been limited to a small number of specific projects and is not to be specified unless approved by the State Bridge Design Engineer.

For design of conventionally reinforced concrete decks, the following requirements apply:

- Use the traditional approximate method of analysis for design of the top and bottom transverse reinforcement. Do not use the empirical deck design method in LRFD Article 9.7.2.
- For analysis, assume the deck is a continuous transverse strip with the beams below as supports.
- For skews less than or equal to  $20^\circ$ , detail deck transverse bars parallel to the skew. For design of the transverse bars, use the beam spacing measured along the skew for the deck span length.
- For skews greater than  $20^\circ$ , detail deck transverse bars at right angles to the centerline of roadway. For design of the transverse bars, use the beam spacing measured normal to the roadway centerline for the deck span length.
- For dead load, include deck self-weight plus a future wearing course of 20 psf. Apply a load factor of 1.25.
- If LRFD Appendix A4 assumptions and limitations are met, use the live load moments provided in LRFD Table A4-1 for design. Apply negative moment live load at the design section specified in LRFD Article 4.6.2.1.6.
- For decks without a wearing course, assume  $\frac{1}{2}$  inch of wear when determining structural depth,  $d$ , for the bottom transverse reinforcement. For decks with a wearing course, do not include the wearing course (sacrificial) when determining structural depth,  $d$ , for the bottom transverse reinforcement.
- Check crack control per LRFD Article 5.6.7 using the Class 2 exposure condition ( $\gamma_e = 0.75$ ). In addition, although the actual concrete clear cover to top transverse bars may exceed 2 inches, calculate  $d_c$  using a maximum clear concrete cover equal to 2 inches.

- For bottom longitudinal reinforcement, provide distribution reinforcement per LRFD Article 9.7.3.2. For bridges with varying beam spacing, base the distribution reinforcement for each unit (where a unit is defined as the number of spans between expansion joints) on the widest beam spacing found within the unit.
  - For the deck region in non-pier areas, provide top longitudinal reinforcement that meets the requirements for shrinkage and temperature reinforcement in LRFD Article 5.10.6.
  - For the deck region over/near a pier, provide top longitudinal reinforcement consistent with the superstructure modeling assumptions:
    - Where deck is continuous, but beams are not continuous, provide reinforcement per Figure 9.2.1.8.
    - Where deck and prestressed beams are continuous, design reinforcement for factored negative moment.
    - Where deck and steel beams are continuous, design reinforcement for factored negative moment and meet requirements of LRFD Article 6.10.1.7. See Figure 9.2.1.9 for additional information.
  - Design the deck overhang to carry the lesser of:
    - the  $M_c$  corresponding to the rail capacity  $R_w$
    - $\frac{4}{3} \cdot M_{cFt}$ ,  
where  $M_{cFt}$  = the barrier flexural resistance about the longitudinal axis corresponding to  $F_t$ .
- See discussion below and Memo to Designers (2017-01) for additional guidance on deck overhang design.

Tables 9.2.1.1 and 9.2.1.2 provide minimum reinforcement requirements based on the traditional deck design method for decks supported on precast pretensioned concrete beams and steel beams, respectively. The tables may be used for all LRFD deck designs that fit the assumptions, as well as for decks of bridges originally designed by the AASHTO Standard Specifications Load Factor method (bridge widenings).

#### **[5.10.6]**

The transverse reinforcement given in Tables 9.2.1.1 and 9.2.1.2 is adequate for interior region deck overhangs (measured from centerline of beam to edge of deck) of up to 40% of the beam spacing when a 36 inch tall Type S concrete barrier which meets NCHRP Report 350 Test Level 4 (TL-4) is used. See Standard Details Manual Part II Figures 5-397.138(A) through 5-397.139(D) for Type S concrete barrier details. For exterior region overhangs (regions where the longitudinal barrier reinforcement is discontinuous, such as end of bridge joints and expansion joints), refer to Memo to Designers (2017-01) for overhang reinforcement requirements.

Decks with geometry or loads that fall outside the Table 9.2.1.1 and 9.2.1.2 assumptions require a special design.

Overhangs are to be designed to meet the strength requirements of Section 13. LRFD A13.4.2 specifies that the moment resistance of the deck overhang must be greater than or equal to the barrier flexural resistance about the longitudinal axis,  $M_c$ . This ensures that the deck will be strong enough to force the yield line failure mechanism to occur in the barrier. However, the barrier flexural resistance in the interior regions can be substantially larger than that required to resist the design collision force. For example, the interior panel of a TL-4, 36 inch Type S barrier on a deck with a wearing course has a capacity  $R_w = 117.4$  kips and a corresponding  $M_c = 17.1$  kip-ft/ft, which is well above the design collision force  $F_t = 54$  kips and corresponding  $M_{cFt} = 7.9$  kip-ft/ft for an NCHRP Report 350 Test Level 4 barrier. Because of the large difference between barrier capacity and collision force, MnDOT requires the deck overhang to carry the lesser of:

- the  $M_c$  corresponding to the rail capacity  $R_w$
- $\frac{4}{3} \cdot M_{cFt}$   
where  $M_{cFt} =$  the barrier flexural resistance about the longitudinal axis corresponding to  $F_t$

Because the yield line equations in LRFD assume the collision load is applied at the top of the barrier, adjustment of collision force  $F_t$  for the difference between the barrier height and height of application is required when  $\frac{4}{3} \cdot M_{cFt}$  governs. Refer to the design example in BDM Article 9.3 and the Memo to Designers (2017-01) for more information.

### Geometry

Figures 9.2.1.4 through 9.2.1.7 show standard practice deck details. Typical deck reinforcement layouts at deck edges and medians are illustrated in the figures.

Use a uniform deck thickness for all spans based on the minimum thickness required for the widest beam spacing. For new bridges, use a 9 inch minimum deck thickness on all vehicular structures and a 7 inch minimum deck thickness on pedestrian bridges. For bridge repair projects on vehicular bridges, a lesser deck thickness (8 inch minimum) may be used when approved by the Regional Bridge Construction Engineer to achieve an acceptable load rating.

For the edge-of-deck thickness, use a uniform thickness in all spans. Refer to Memo to Designers (2017-01) for additional guidance regarding the edge-of-deck thickness.

The standard height for bridge sidewalks at the gutter line is 6 inches above the top of roadway. For bridge medians, match approach roadway median shape and height as shown in the preliminary bridge plan.

Dimension the bottom of deck on the outside of the fascia beam at 1 inch below the top of the beam for prestressed concrete beams. For steel beams, detail the bottom of deck on the outside of the fascia beam to meet the bottom of the top flange. See Figures 9.2.1.4 through 9.2.1.7.

Check the slope of the bottom of the deck on overhangs. Confirm that the bottom edge of the deck is higher than the location next to the beam top flange.

### **Detailing**

For main transverse deck reinforcement, provide straight bars located in both the top and the bottom reinforcing mats. Refer to Memo to Designers (2017-01) for some exceptions to this in the deck overhang where hooked bars are required.

The main transverse reinforcement will vary with the beam spacing. For skewed bridges where the beam spacing changes from one span to another, continue the reinforcement for the wider beam spacing until the reinforcement is completely outside of the span with the wider beam spacing.

For the acute corners of highly skewed bridges, detail the deck reinforcement as follows: In addition to the 2-#5 bars that run parallel to the expansion joint at the end of the deck, place 2 top mat #5 bars that are 10 feet long and run parallel to the joint with a spacing of 5 inches. Also, run a series of radial transverse bars that shorten as they progress into the corner. Finally, place a bent bar in the corner that ties to the outside deck longitudinal bar and the end bar running parallel to the joint. See Figure 9.2.1.1.

Add a longitudinal tie at the end of the deck if the deck projects past the end of the diaphragm more than 1 foot.

For bridges with transverse deck reinforcement parallel to the skew, dimension transverse bar spacing along edge of deck.

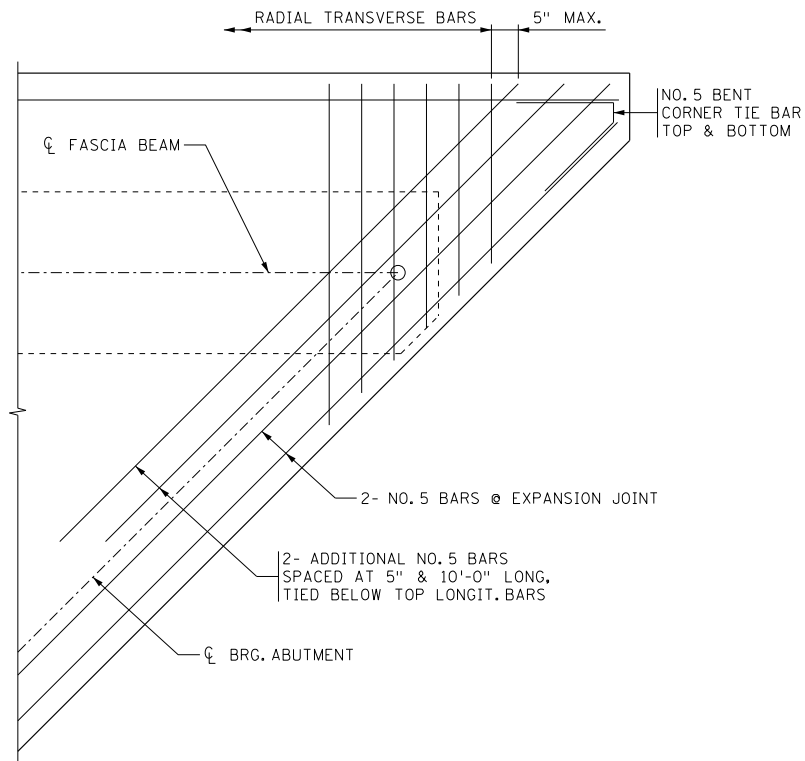

TYPICAL DECK REINFORCEMENT PLAN FOR HIGHLY SKEWED CORNERS

**Figure 9.2.1.1**

Several detailing practices are to be used near piers:

- Detail longitudinal steel (temperature and distribution) as continuous over piers.
- Provide additional longitudinal steel to minimize transverse deck cracking. See Figures 9.2.1.8 and 9.2.1.9.
- For decks supported on non-continuous prestressed beams, detail a partial depth sawcut in the deck over the pier backfilled with a sealant. See Figure 9.2.1.10.
- Place polystyrene on the corners of prestressed concrete beam bridges with skews greater than 20° to reduce wandering of the transverse deck crack at the centerline of pier. See Figure 9.2.1.10.

**Deck Placement Sequence**

One contributor to through-deck transverse cracking is inadequate sequencing of deck pours. Provide a deck placement sequence for the following types of bridges:

- Bridges with decks wider than 90 feet.
- Continuous bridges with spans exceeding 150 feet.



- Bridges where the concrete placement rate is lower than 60% of the span length per hour. (Note that a single pump truck can be assumed to maintain a pour rate of 70 cubic yards per hour.)

The overall goal of the deck placement sequence is have minimal tension in the deck due to self-weight when the entire deck is complete.

Generally, for continuous superstructures containing span lengths between 150 and 200 feet, locate the transverse construction joint for the first pour at the 0.6 point of the first span. Start the following pour at the 0.6 point of the adjacent span and proceed toward and terminate at the end of the previous pour. Continue this pattern for all interior spans. The last placement will extend from the end of the bridge to the previous placement. A typical deck placement sequence for a 3 span bridge fitting the above criteria is shown in Figure 9.2.1.2.

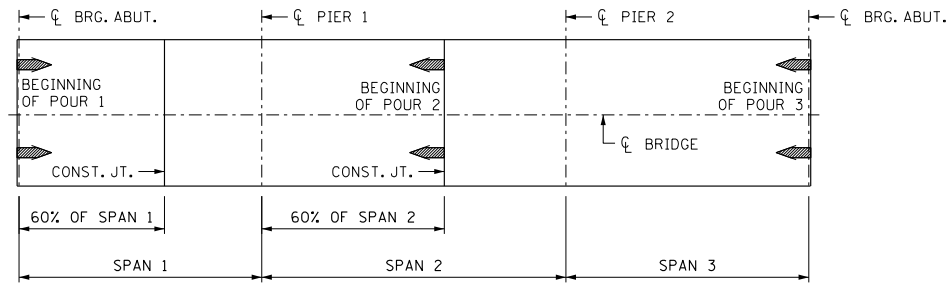
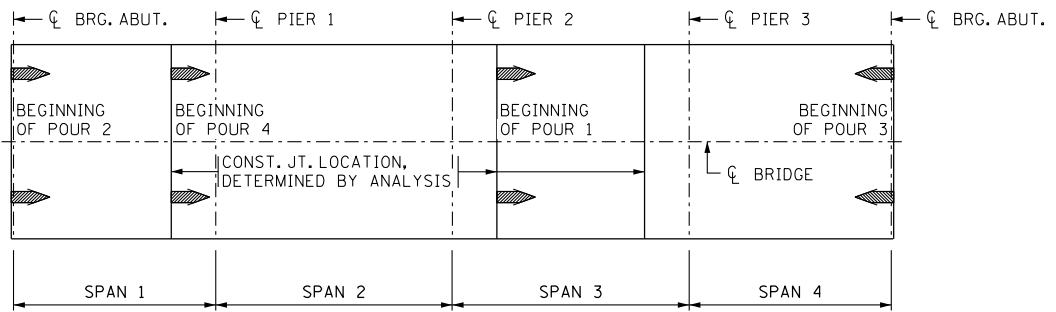

Figure 9.2.1.2

For continuous superstructures containing span lengths greater than 200 feet, conduct an analysis to determine construction joint locations for the deck pour sequence. For the initial trial, set the joint locations at points of dead load contraflexure. Choose a pour sequence that minimizes upward deflections in previously placed spans (i.e. longer pour sections should be placed before shorter adjacent sections). Place positive moment sections prior to negative moment sections. Next, analyze the deck for the initial trial pour sequence to determine the cumulative stresses in the deck. Then begin adjusting construction joint locations and reanalyzing until the pour sequence with the lowest tension stresses in the deck is reached. An acceptable pour sequence for a multi-span bridge fitting the above criteria is shown in Figure 9.2.1.3. Since adjacent spans may not be poured within 72 hours of each other, the second pour is permitted to be the next most flexible section after the first pour. Note that the third and fourth pours require placement of both positive and negative moment sections. If the



**Figure 9.2.1.3**

contractor will be unable to complete the placement of the entire section in one pour, the positive moment area is to be placed first followed by the negative sections.

For superstructures which consist of a series of simply supported spans that require a deck placement sequence, locate transverse construction joints at the end of a span.

Where possible, consider orienting the direction of the concrete pours in the uphill direction, allowing gravity to reduce possible tension in the deck.

On bridges with strip seal expansion joints where a deck pour begins at the abutment, investigate the effects of beam end rotation. Too much rotation can negatively affect the joint size or cause deck and end block formwork to fail if not appropriately handled during concrete placement. If this is a problem, consider revising the pour sequence or placing the abutment end block after the deck is complete.

In all cases, a minimum of 72 hours is required between adjacent deck pours.

For unusual span length configurations, discuss the deck placement sequence with the Regional Bridge Construction Engineer.

**Design Assumptions for Deck Reinforcement Tables 9.2.1.1 and 9.2.1.2:**

- Transverse reinforcement is based on the traditional deck design method.
- Concrete strength,  $f'_c = 4$  ksi.
- Epoxy coated steel rebar strength,  $f_y = 60$  ksi.
- Dead load includes deck self-weight plus a future wearing course of 0.020 ksf. A load factor of 1.25 was applied to the future wearing course. Dead load bending moment is based on equation  $M_{DC} = w_{DC} \cdot L^2/10$ .
- Positive live load moments were taken from LRFD Table A4-1.
- Negative live load moments were interpolated from values in LRFD Table A4-1.
- Concrete clear cover for top transverse reinforcement is 3".
- Concrete clear cover for bottom transverse reinforcement is 1".
- For decks without a wearing course, 1/2" wear was assumed in determining the structural depth,  $d_s$ , for the bottom transverse reinforcement.
- For decks with a wearing course, the 2" wearing course was not used (sacrificial) in determining structural depth,  $d_s$ , for the bottom transverse reinforcement.
- Crack control used a Class 2 exposure condition ( $\gamma_e = 0.75$ ).
- For crack control check, although the actual concrete clear cover to top transverse bars exceeds 2 inches,  $d_c$  calculation used a maximum clear concrete cover equal to 2 inches.
- LRFD Art. 9.7.2.4 (under empirical design) requires that the ratio of the effective beam spacing to slab thickness be less than 18. The slab thicknesses given in the tables fit these requirements and are similar to what MnDOT has used successfully in the past.
- Bottom longitudinal reinforcement is distribution reinforcement per LRFD Article 9.7.3.2.

**EPOXY COATED STEEL REINFORCEMENT FOR DECKS SUPPORTED ON  
PRECAST PRETENSIONED CONCRETE BEAMS**

Negative moment design section is assumed at 10 inches from centerline for I-beams, based on 1/3 of the M-series beam top flange per LRFD Article 4.6.2.1.6 (conservative for MN-series and MW-series beams). Similarly, negative moment design section is assumed at 8.7 inches from centerline for rectangular beams, which is based on 1/3 of the rectangular beam width.

| Maximum Beam Spacing <sup>①</sup> | Transverse Reinforcement Size and Spacing |                        |                |                          | Deck Thickness T <sup>②</sup> | Longitudinal Reinforcement Size and Spacing, Bottom Mat <sup>③</sup> | Longitudinal Reinforcement Size and Spacing, Top Mat <sup>③</sup> |
|-----------------------------------|---|------------------------|----------------|--------------------------|-------------------------------|--|---|
|                                   | Bottom Mat                                |                        | Top Mat        |                          |                               |  |   |
|                                   | With Wearing Course                       | Without Wearing Course | Deck on I-Beam | Deck on Rectangular Beam |                               |  |   |
| 5'-0"                             | 4 @ 6.5"                                  | 4 @ 9"                 | 4 @ 10"        | 4 @ 9.5"                 | 9"                            | 4 @ 9"   | 4 @ 1'-6"   |
| 5'-6"                             | 4 @ 6.5"                                  | 4 @ 8.5"               | 4 @ 9"         | 4 @ 8.5"                 | 9"                            | 4 @ 9"   | 4 @ 1'-6"   |
| 6'-0"                             | 4 @ 6.5"                                  | 4 @ 8"                 | 4 @ 8.5"       | 4 @ 8"                   | 9"                            | 4 @ 9"   | 4 @ 1'-6"   |
| 6'-6"                             | 4 @ 6"                                    | 4 @ 8"                 | 4 @ 8"         | 4 @ 7.5"                 | 9"                            | 4 @ 9"   | 4 @ 1'-6"   |
| 7'-0"                             | 4 @ 5.5"                                  | 4 @ 7.5"               | 4 @ 7.5"       | 4 @ 7"                   | 9"                            | 4 @ 8"   | 4 @ 1'-6"   |
| 7'-6"                             | 4 @ 5.5"                                  | 4 @ 7"                 | 4 @ 7"         | 4 @ 6.5"                 | 9"                            | 4 @ 8"   | 4 @ 1'-6"   |
| 8'-0"                             | 4 @ 5"                                    | 4 @ 6.5"               | 4 @ 6.5"       | 4 @ 6.5"                 | 9"                            | 4 @ 7"   | 4 @ 1'-6"   |
| 8'-6"                             | 5 @ 7.5"                                  | 4 @ 6"                 | 4 @ 6.5"       | 4 @ 6"                   | 9"                            | 4 @ 7"   | 4 @ 1'-6"   |
| 9'-0"                             | 5 @ 7"                                    | 4 @ 6"                 | 4 @ 6"         | 4 @ 6"                   | 9"                            | 5 @ 10"  | 4 @ 1'-6"   |
| 9'-6"                             | 5 @ 6.5"                                  | 4 @ 5.5"               | 4 @ 6"         | 4 @ 5.5"                 | 9"                            | 5 @ 9"   | 4 @ 1'-6"   |
| 10'-0"                            | 5 @ 6"                                    | 4 @ 5.5"               | 4 @ 5.5"       | 4 @ 5"                   | 9"                            | 5 @ 8"   | 4 @ 1'-6"   |
| 10'-6"                            | 5 @ 6"                                    | 4 @ 5"                 | 4 @ 5"         | 5 @ 6.5"                 | 9"                            | 5 @ 8"   | 4 @ 1'-6"   |
| 11'-0"                            | 5 @ 5.5"                                  | 5 @ 7.5"               | 5 @ 6"         | 5 @ 6"                   | 9"                            | 5 @ 8"   | 4 @ 1'-6"   |
| 11'-6"                            | 5 @ 5.5"                                  | 5 @ 7"                 | 5 @ 5.5"       | 5 @ 5.5"                 | 9"                            | 5 @ 8"   | 4 @ 1'-6"   |
| 12'-0"                            | 5 @ 5"                                    | 5 @ 6.5"               | 5 @ 5.5"       | 5 @ 5.5"                 | 9"                            | 5 @ 7"   | 4 @ 1'-6"   |
| 12'-6"                            | 6 @ 7"                                    | 5 @ 6.5"               | 5 @ 5"         | 5 @ 5"                   | 9"                            | 5 @ 7"   | 4 @ 1'-6"   |
| 13'-0"                            | 6 @ 7"                                    | 5 @ 6.5"               | 5 @ 5"         | 5 @ 5"                   | 9.5"                          | 5 @ 7"   | 4 @ 1'-6"   |
| 13'-6"                            | 6 @ 7.5"                                  | 5 @ 6.5"               | 5 @ 5"         | 5 @ 5"                   | 9.75"                         | 5 @ 8"   | 4 @ 1'-6"   |
| 14'-0"                            | 6 @ 7"                                    | 5 @ 6.5"               | 5 @ 5"         | 6 @ 6"                   | 10"                           | 5 @ 8"   | 4 @ 1'-6"   |
| 14'-6"                            | 6 @ 7.5"                                  | 5 @ 6.5"               | 5 @ 5"         | 6 @ 6"                   | 10.25"                        | 5 @ 8"   | 4 @ 1'-6"   |
| 15'-0"                            | 6 @ 7.5"                                  | 5 @ 6.5"               | 5 @ 5"         | 6 @ 6"                   | 10.5"                         | 5 @ 8"   | 4 @ 1'-6"   |

① For skews ≤ 20°, beam spacing is measured along the skew.  
For skews > 20°, beam spacing is measured normal to roadway centerline.

② Deck thickness includes wearing course.

③ Reinforcement shown is for deck regions in non-pier areas only and is based on LRFD 5.10.6. Note that additional reinforcement is required for deck regions over/near piers. See Figure 9.2.1.8 for additional top longitudinal reinforcement required in deck regions over/near piers when only deck is continuous. For beams made continuous, design longitudinal reinforcement in deck regions over/near piers for factored negative moment.

**Table 9.2.1.1**

**EPOXY COATED STEEL REINFORCEMENT FOR DECKS SUPPORTED ON STEEL BEAMS**

Negative moment design section is assumed at 3 inches from centerline of beam, based on 1/4 of a 12 inch top flange per LRFD Article 4.6.2.1.6.

| Maximum Beam Spacing <sup>①</sup> | Transverse Reinforcement Size and Spacing |                        |          | Deck Thickness T <sup>②</sup> | Longitudinal Reinforcement Size and Spacing, Bottom Mat <sup>③</sup> | Longitudinal Reinforcement Size and Spacing, Top Mat <sup>③</sup> |
|-----------------------------------|---|------------------------|----------|-------------------------------|--|---|
|                                   | Bottom Mat                                |                        | Top Mat  |                               |  |   |
|                                   | With Wearing Course                       | Without Wearing Course |          |                               |  |   |
| 5'-0"                             | 4 @ 6.5"                                  | 4 @ 9"                 | 4 @ 8"   | 9"                            | 4 @ 9"   | 4 @ 1'-6"   |
| 5'-6"                             | 4 @ 6.5"                                  | 4 @ 8.5"               | 4 @ 7"   | 9"                            | 4 @ 9"   | 4 @ 1'-6"   |
| 6'-0"                             | 4 @ 6.5"                                  | 4 @ 8"                 | 4 @ 6.5" | 9"                            | 4 @ 9"   | 4 @ 1'-6"   |
| 6'-6"                             | 4 @ 6"                                    | 4 @ 8"                 | 4 @ 6"   | 9"                            | 4 @ 9"   | 4 @ 1'-6"   |
| 7'-0"                             | 4 @ 5.5"                                  | 4 @ 7.5"               | 4 @ 5.5" | 9"                            | 4 @ 8"   | 4 @ 1'-6"   |
| 7'-6"                             | 4 @ 5.5"                                  | 4 @ 7"                 | 4 @ 5.5" | 9"                            | 4 @ 8"   | 4 @ 1'-6"   |
| 8'-0"                             | 4 @ 5"                                    | 4 @ 6.5"               | 4 @ 5"   | 9"                            | 4 @ 7"   | 4 @ 1'-6"   |
| 8'-6"                             | 5 @ 7.5"                                  | 4 @ 6"                 | 5 @ 6.5" | 9"                            | 4 @ 7"   | 4 @ 1'-6"   |
| 9'-0"                             | 5 @ 7"                                    | 4 @ 6"                 | 5 @ 6.5" | 9"                            | 4 @ 6"   | 4 @ 1'-6"   |
| 9'-6"                             | 5 @ 6.5"                                  | 4 @ 5.5"               | 5 @ 6"   | 9"                            | 4 @ 6"   | 4 @ 1'-6"   |
| 10'-0"                            | 5 @ 6"                                    | 4 @ 5.5"               | 5 @ 6"   | 9"                            | 4 @ 5"   | 4 @ 1'-6"   |
| 10'-6"                            | 5 @ 6"                                    | 4 @ 5"                 | 5 @ 5.5" | 9"                            | 4 @ 5"   | 4 @ 1'-6"   |
| 11'-0"                            | 5 @ 6"                                    | 4 @ 5"                 | 5 @ 5.5" | 9.25"                         | 4 @ 5"   | 4 @ 1'-6"   |
| 11'-6"                            | 5 @ 6"                                    | 4 @ 5"                 | 5 @ 5"   | 9.5"                          | 4 @ 5"   | 4 @ 1'-6"   |
| 12'-0"                            | 5 @ 6"                                    | 5 @ 7.5"               | 5 @ 5"   | 9.75"                         | 4 @ 6"   | 4 @ 1'-6"   |
| 12'-6"                            | 5 @ 6"                                    | 5 @ 7.5"               | 5 @ 5"   | 10"                           | 4 @ 6"   | 4 @ 1'-6"   |
| 13'-0"                            | 5 @ 6"                                    | 5 @ 7.5"               | 6 @ 6.5" | 10.25"                        | 4 @ 6"   | 4 @ 1'-6"   |
| 13'-6"                            | 5 @ 6"                                    | 5 @ 7"                 | 6 @ 6.5" | 10.5"                         | 4 @ 6"   | 4 @ 1'-6"   |
| 14'-0"                            | 5 @ 6"                                    | 5 @ 7"                 | 6 @ 6.5" | 10.75"                        | 4 @ 6"   | 4 @ 1'-6"   |
| 14'-6"                            | 5 @ 5.5"                                  | 5 @ 7"                 | 6 @ 6.5" | 11"                           | 4 @ 6"   | 4 @ 1'-6"   |
| 15'-0"                            | 5 @ 5.5"                                  | 5 @ 7"                 | 6 @ 6.5" | 11.25"                        | 4 @ 6"   | 4 @ 1'-6"   |

① For skews ≤ 20°, beam spacing is measured along the skew.

For skews > 20°, beam spacing is measured normal to roadway centerline.

② Deck thickness includes wearing course.

③ Reinforcement shown is for positive moment region only and is based on LRFD 5.10.6. Where deck and steel beams are continuous, design longitudinal reinforcement in negative moment regions for the factored negative moment and meet requirements of LRFD Article 6.10.1.7. See Figure 9.2.1.9 for longitudinal reinforcing requirements in negative moment regions.

**Table 9.2.1.2**

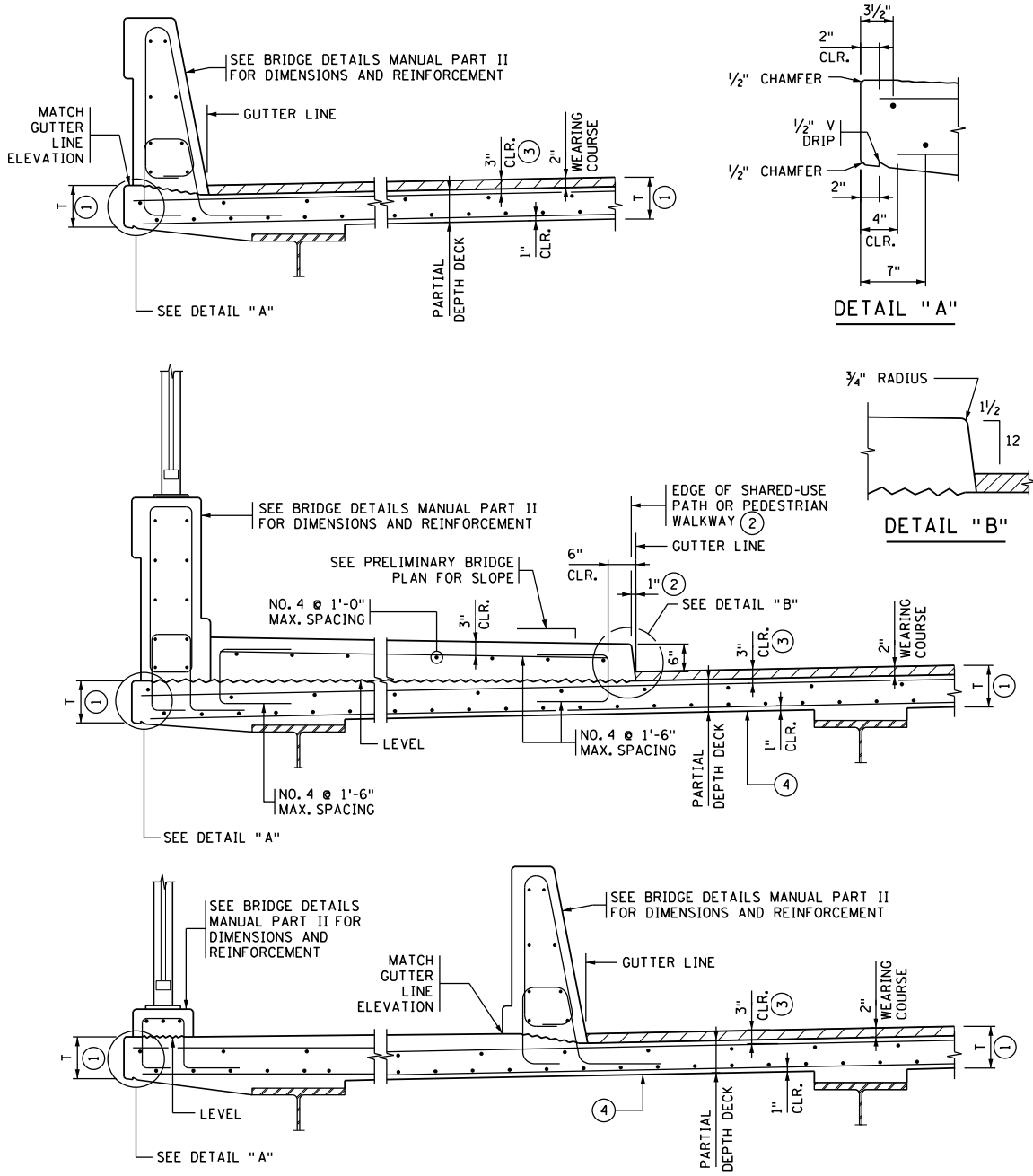

- ① T EQUALS DECK THICKNESS GIVEN IN TABLE 9.2.1.1 OR 9.2.1.2 OF THIS MANUAL.
- ② LOCATION OF TOP EDGE OF SHARED-USE PATH OR PEDESTRIAN WALKWAY IS DEFINED AS 1" OUTSIDE OF GUTTER LINE.
- ③ CONCRETE CLEAR COVER SHOWN IS FOR EPOXY COATED STEEL BARS. COVER MAY DIFFER FOR OTHER BAR TYPES.
- ④ FOR CROWN SECTION SLOPE BOTTOM OF DECK TO MATCH TOP OF ROADWAY SLOPE. CONTINUE SLOPE UNDER SIDEWALK TO FASCIA BEAM. FOR SUPERELEVATED SECTION WITH SIDEWALK ON HIGH SIDE OF DECK, ADJUST FASCIA BEAM VERTICAL LOCATION AS NEEDED TO PROVIDE A MINIMUM PARTIAL DEPTH DECK THICKNESS EQUAL TO T-2.

**CONCRETE DECK REINFORCEMENT SECTIONS**  
(WITH CONCRETE WEARING COURSE)

*Figure 9.2.1.4*

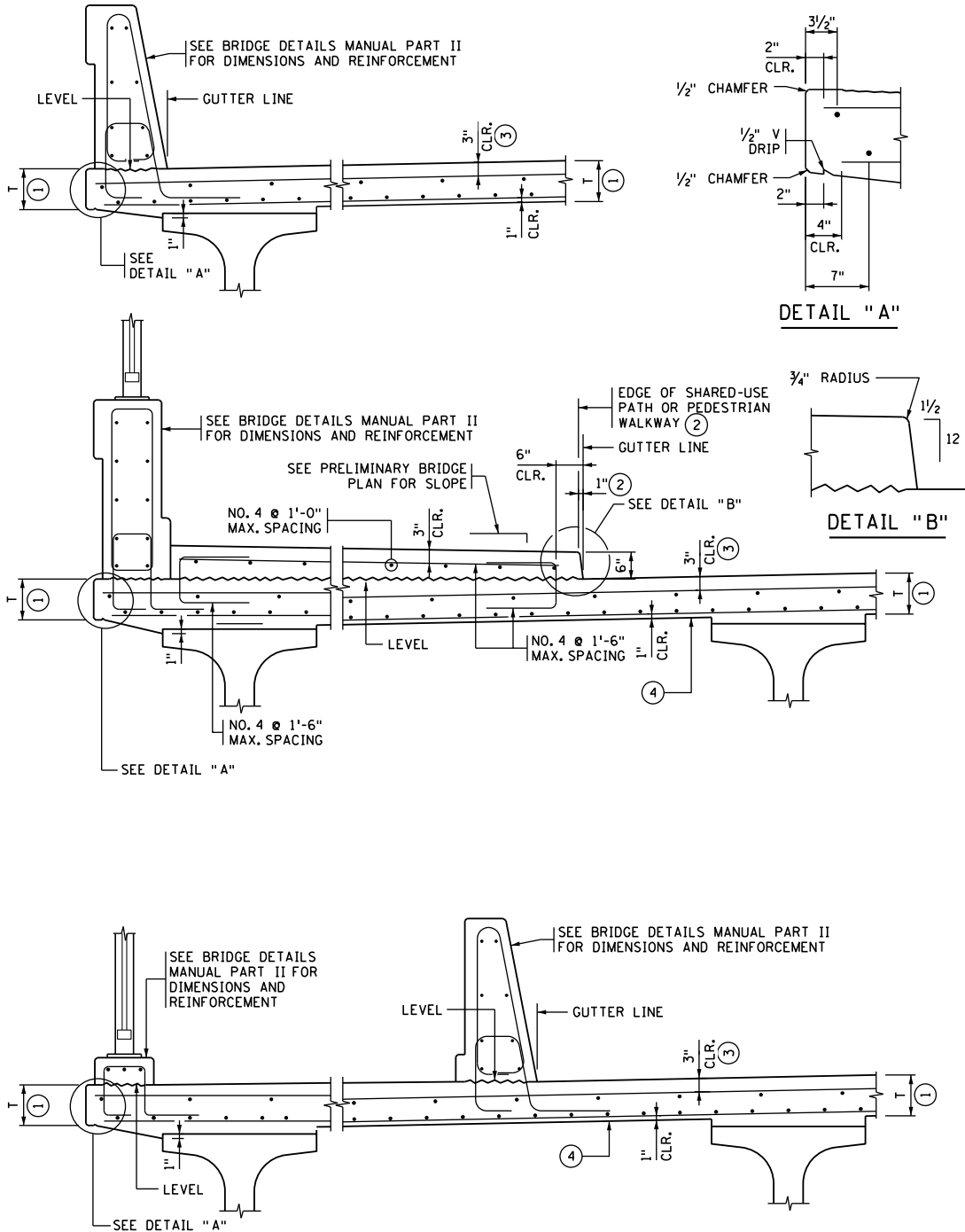

- ① T EQUALS DECK THICKNESS GIVEN IN TABLE 9.2.1.1 OR 9.2.1.2 OF THIS MANUAL.
- ② LOCATION OF TOP EDGE OF SHARED-USE PATH OR PEDESTRIAN WALKWAY IS DEFINED AS 1" OUTSIDE OF GUTTER LINE.
- ③ CONCRETE CLEAR COVER SHOWN IS FOR EPOXY COATED STEEL BARS. COVER MAY DIFFER FOR OTHER BAR TYPES.
- ④ FOR CROWN SECTION SLOPE BOTTOM OF DECK TO MATCH TOP OF ROADWAY SLOPE. CONTINUE SLOPE UNDER SIDEWALK TO FASCIA BEAM. FOR SUPERELEVATED SECTION WITH SIDEWALK ON HIGH SIDE OF DECK, ADJUST FASCIA BEAM VERTICAL LOCATION AS NEEDED TO PROVIDE A MINIMUM PARTIAL DEPTH DECK THICKNESS EQUAL TO T-2.

**CONCRETE DECK REINFORCEMENT SECTIONS**

(WITHOUT CONCRETE WEARING COURSE)

**Figure 9.2.1.5**

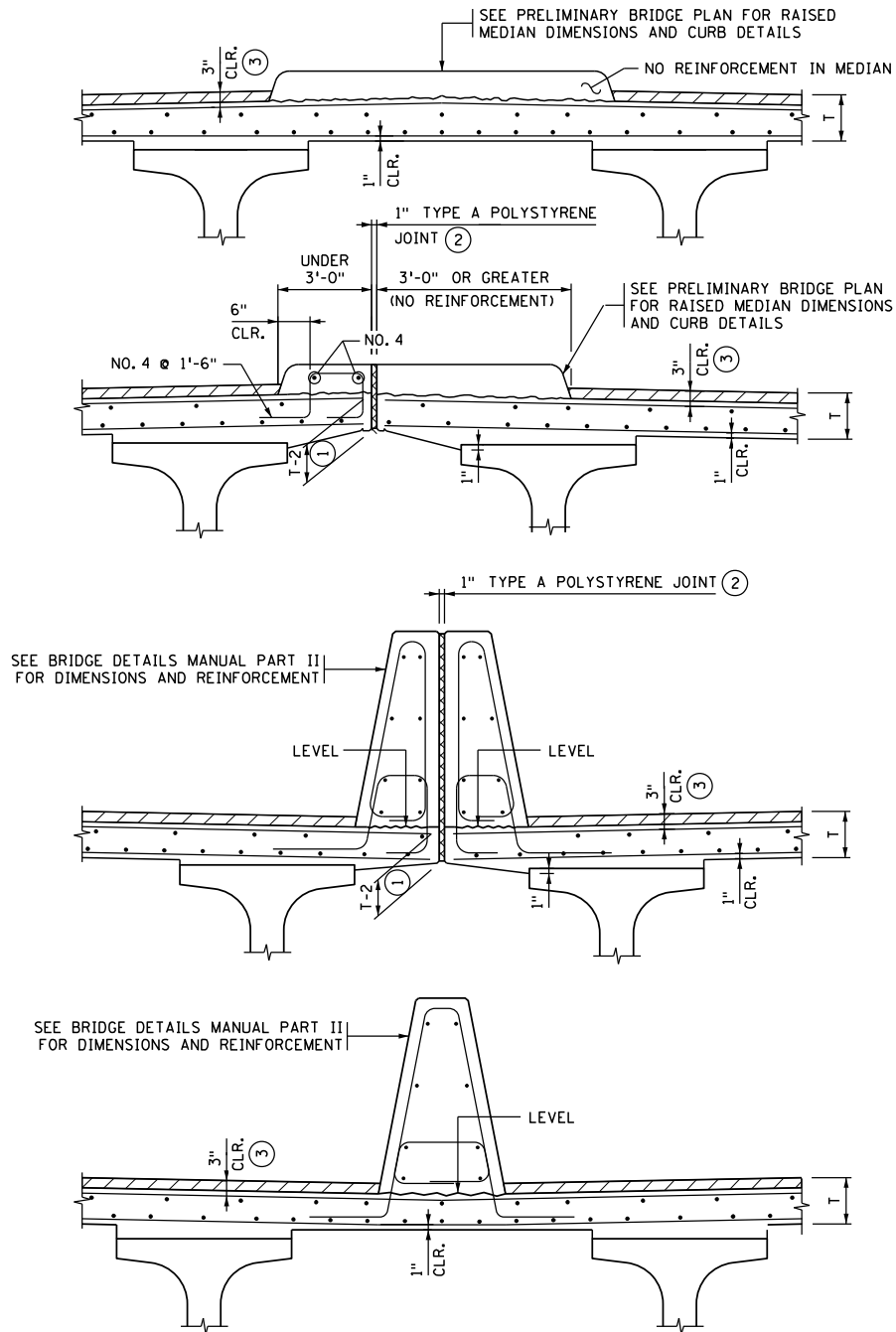

**NOTES:**

IF BOTH SHOULDER AREAS SLOPE INTO BARRIER BOTH ADJACENT BEAMS MAY HAVE TO DROP TO PREVENT NEGATIVE STOOLS.

- (1) T EQUALS DECK THICKNESS GIVEN IN TABLE 9.2.1.1. OR 9.2.1.2 OF THIS MANUAL.
- (2) PROVIDE SPLIT MEDIAN CAP WHEN REQUIRED BY REGIONAL BRIDGE CONSTRUCTION ENGINEER.
- (3) CONCRETE CLEAR COVER SHOWN IS FOR EPOXY COATED STEEL BARS. COVER FOR OTHER BARS MAY DIFFER.

**CONCRETE DECK REINFORCEMENT SECTIONS**  
(WITH CONCRETE WEARING COURSE)

**Figure 9.2.1.6**



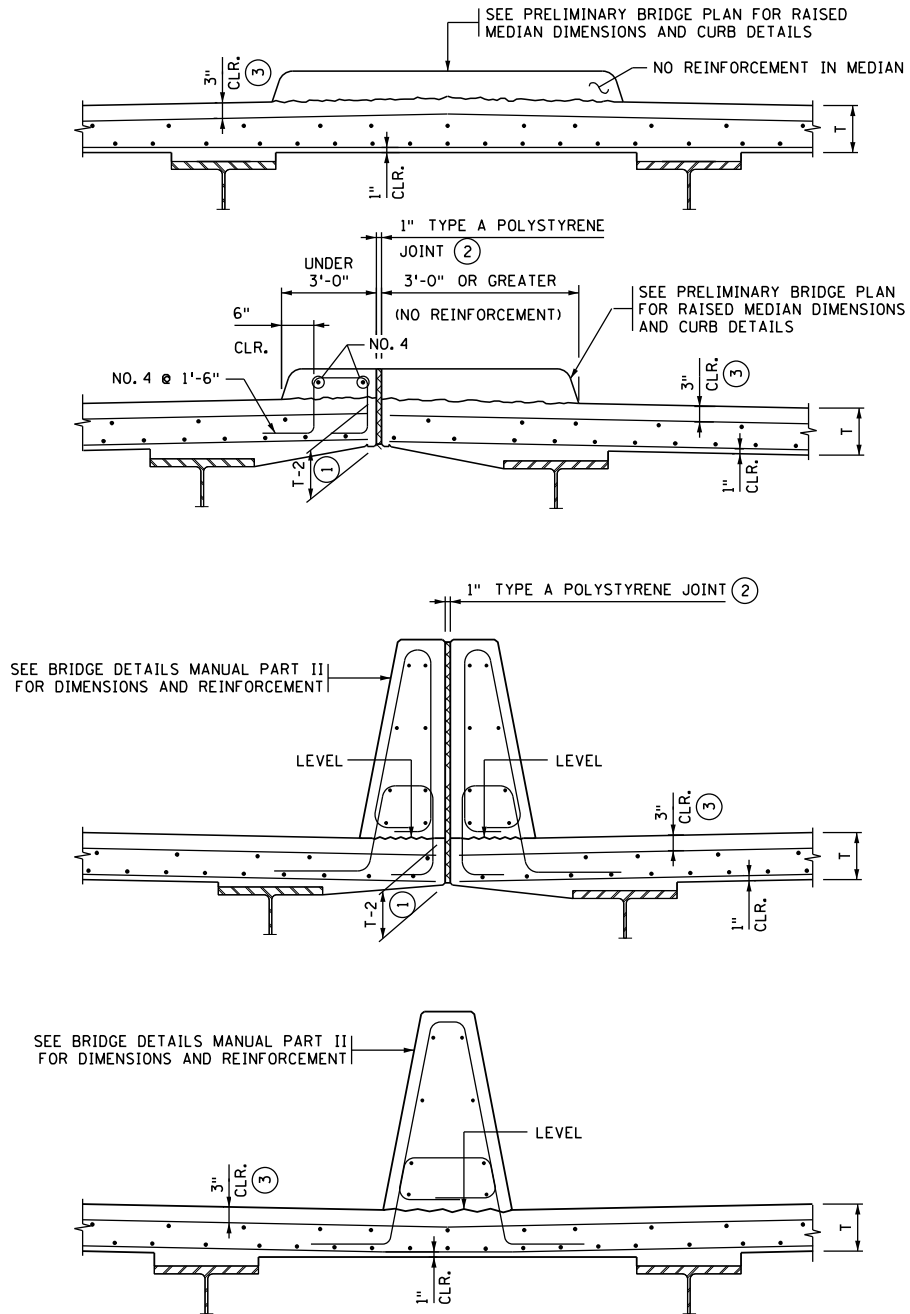

**NOTES:**

IF BOTH SHOULDER AREAS SLOPE INTO BARRIER BOTH ADJACENT BEAMS MAY HAVE TO DROP TO PREVENT NEGATIVE STOOLS.

- ① T EQUALS DECK THICKNESS GIVEN IN TABLE 9.2.1.1. OR 9.2.1.2 OF THIS MANUAL.
- ② PROVIDE SPLIT MEDIAN CAP WHEN REQUIRED BY REGIONAL BRIDGE CONSTRUCTION ENGINEER.
- ③ CONCRETE CLEAR COVER SHOWN IS FOR EPOXY COATED STEEL BARS. COVER FOR OTHER BARS MAY DIFFER.

**CONCRETE DECK REINFORCEMENT SECTIONS**  
(WITH CONCRETE WEARING COURSE)

**Figure 9.2.1.7**

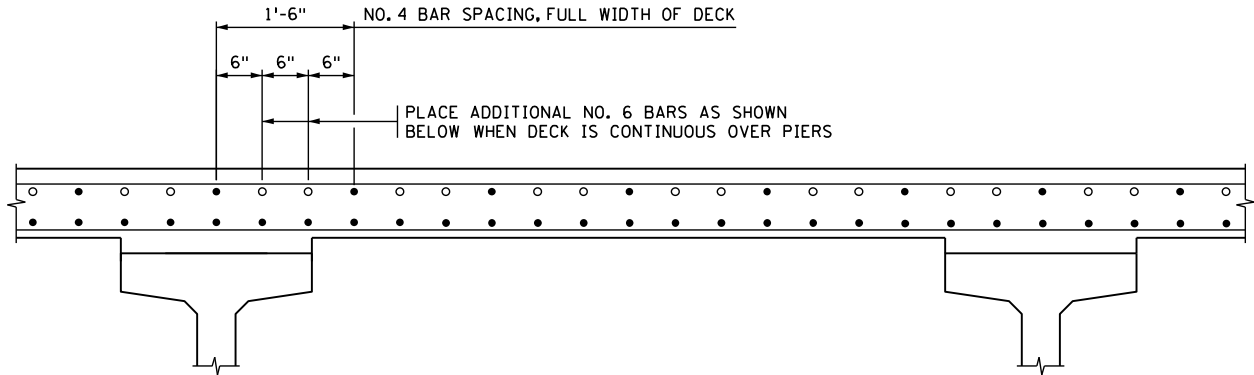

TRANSVERSE SECTION

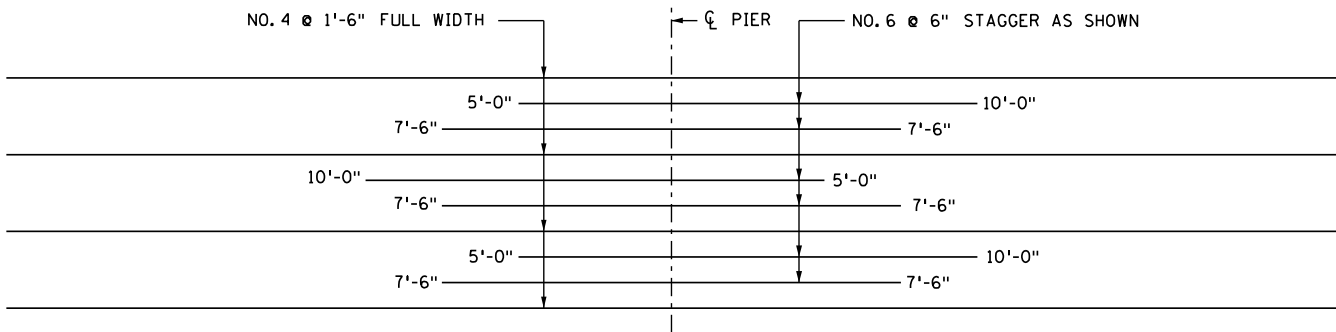

PLAN OF TOP LONGITUDINAL REINFORCEMENT AT PIER

LONGITUDINAL REINFORCEMENT FOR CONCRETE DECK WITH MAIN REINFORCEMENT PERPENDICULAR TO TRAFFIC WITH ONLY DECK (NOT BEAMS) CONTINUOUS OVER PIER

CONCRETE DECK REINFORCEMENT DETAILS FOR PRESTRESSED CONCRETE BEAM SPANS

*Figure 9.2.1.8*

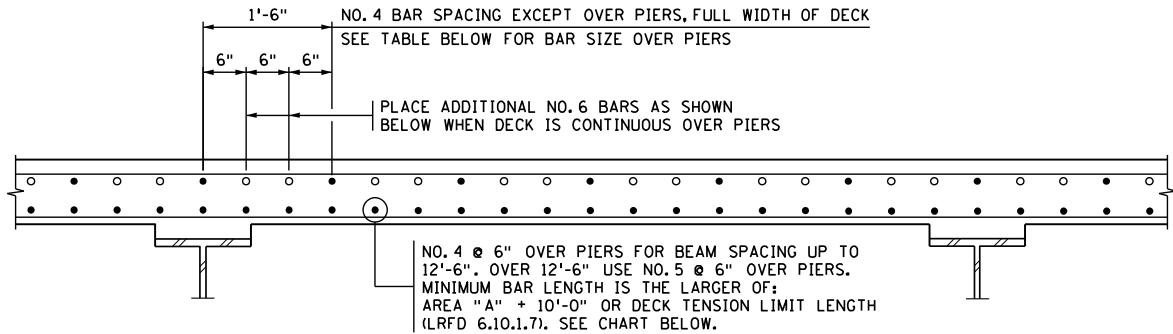

TRANSVERSE SECTION

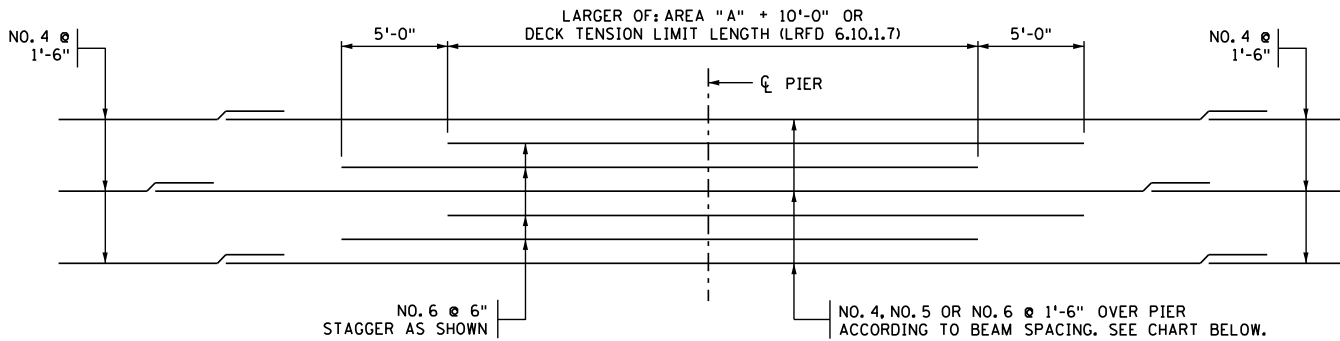

PLAN OF TOP LONGITUDINAL REINFORCEMENT AT PIER

| THROUGH REINFORCEMENT OVER PIERS |                     |                  |
|----------------------------------|---------------------|------------------|
| BEAM SPACING                     | BOTTOM LONGITUDINAL | TOP LONGITUDINAL |
| UP TO 10'-6"                     | NO. 4 @ 6"          | NO. 4 @ 1'-6"    |
| OVER 10'-6" TO 12'-6"            | NO. 4 @ 6"          | NO. 5 @ 1'-6"    |
| OVER 12'-6" TO 14'-6"            | NO. 5 @ 6"          | NO. 6 @ 1'-6"    |
| OVER 14'-6"                      | SPECIAL DESIGN      |                  |

PERMISSIBLE SPLICES IN REINFORCEMENT BARS TO BE LOCATED  
AWAY FROM  $\zeta$  OF PIER AND ALTERNATED ON EACH SIDE OF PIER

LONGITUDINAL REINFORCEMENT FOR CONCRETE DECK WITH MAIN REINFORCEMENT  
PERPENDICULAR TO TRAFFIC AND CONTINUOUS OVER 3 OR MORE BEAMS

CONCRETE DECK REINFORCEMENT DETAILS FOR  
CONTINUOUS STEEL BEAM SPANS (AASHTO LRFD 6.10.1.7)

Figure 9.2.1.9

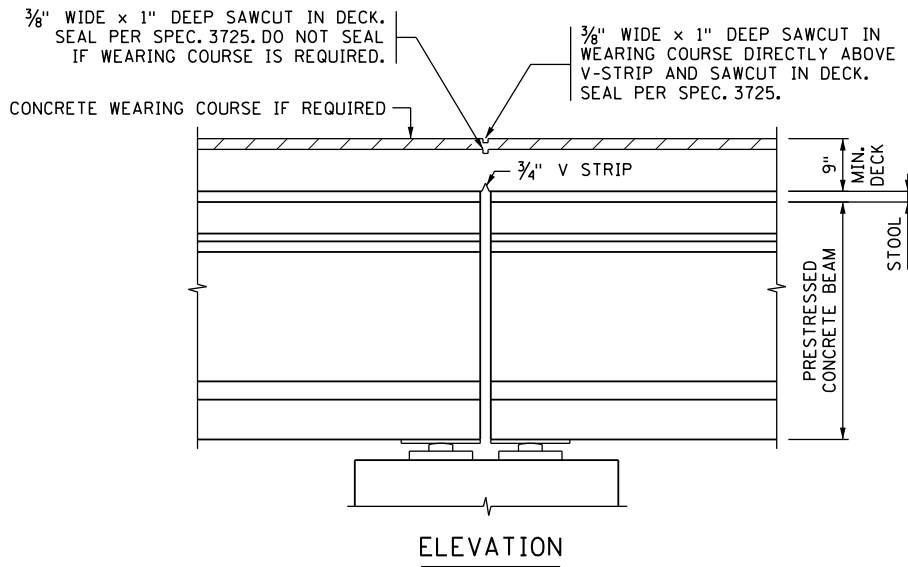
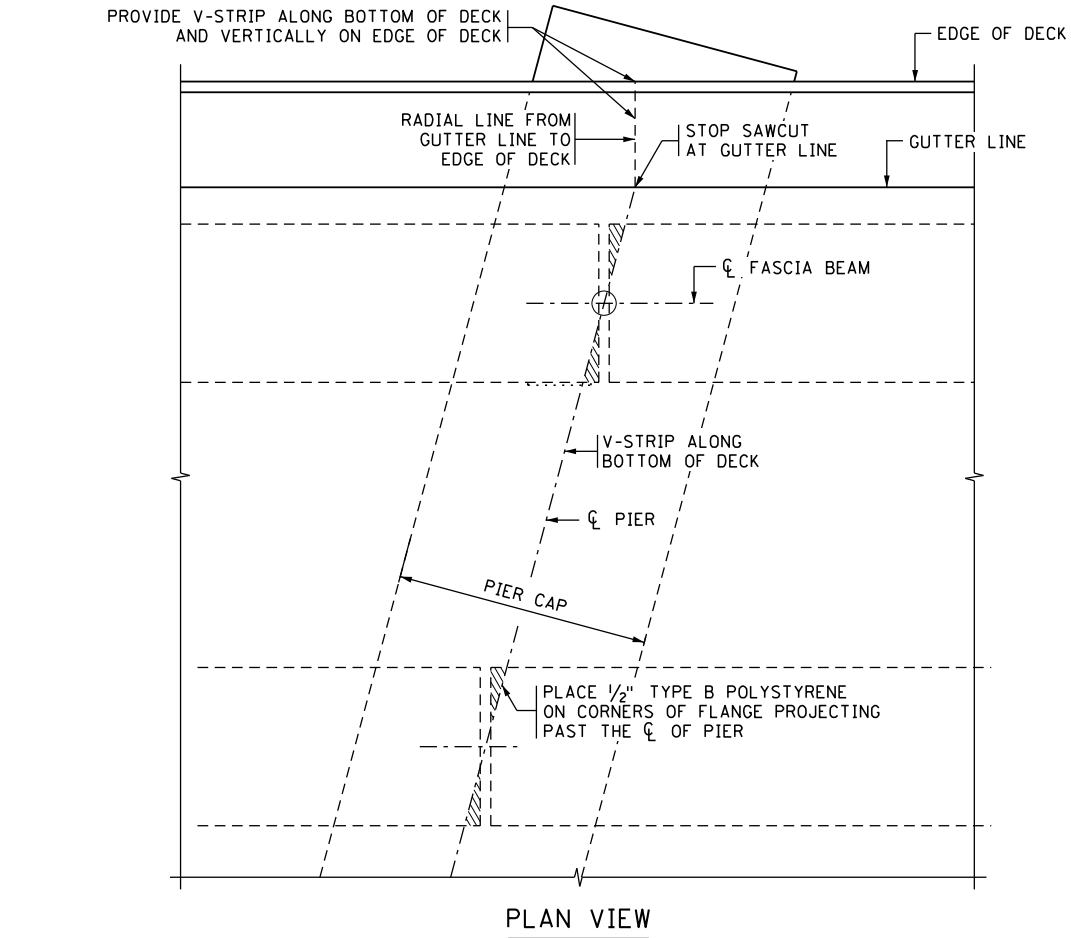

SAWCUT DETAIL AT PIERS  
(CONTINUOUS DECK OVER NON-CONTINUOUS PRESTRESSED BEAMS)

**Figure 9.2.1.10**

**9.3 Reinforced  
Concrete Deck  
Design Example**

This example demonstrates the design of a reinforced concrete deck supported on MN63 pretensioned concrete I-beams. The first part describes the design of the deck interior region (between the fascia beams) and the second part provides design procedures for the deck overhang region.

**[4.6.2.1]**

The deck is designed using the traditional approximate analysis method. The deck is assumed to carry traffic loads to the beam supports via one-way slab or beam action. The beams are parallel to the direction of traffic and the substructures are not skewed, so the primary reinforcement for the deck is placed perpendicular to the beams. Distribution steel is placed parallel to the beams.

**[9.7.3.2]**

The reinforced concrete deck section with wearing course is illustrated in Figure 9.3.1.

**A. Material and  
Design Parameters**

**[9.7.1.1]**

**[9.7.1.3]**

**Deck**

Unit weight of deck and wearing course (for loads),  $w_c = 0.150$  kcf

Unit weight of deck and wearing course (for  $E_c$ ),  $w_{cE} = 0.145$  kcf

Skew angle of bridge,  $\theta = 0$  degrees

Out-to-out bridge deck transverse width,  $b_{deck} = 52.00$  ft = 624 in

Weight of future wearing course,  $w_{fws} = 0.020$  kcf

Yield strength of reinforcing bars,  $f_y = 60$  ksi

Reinforcing bar modulus of elasticity,  $E_s = 29,000$  ksi

28 day concrete strength,  $f'_c = 4$  ksi

Center-to-center beam spacing,  $L_s = 9.00$  ft

Railing weight,  $w_{barrier} = 0.513$  klf (see Std. Figure 5-397.139(B))

Beam flange width,  $b_f = 34$  in (MN63 Prestressed I-Beam)

Deck overhang = 3.50 ft

**B. Structural  
Analysis of  
Interior Region  
[9.6.1]**

The deck is modeled as a continuous beam on pinned supports provided at the centerline of the supporting beams. The beams are assumed to be rigid, not permitting vertical movement. Recognizing that beams have top flanges that provide support for the deck over a finite dimension, the specifications permit designing negative moment reinforcement for locations that are offset from the centerline of the beam.

**[4.6.2.1.6]**

For prestressed beams, negative moments are checked at the design section located  $1/3$  of the flange width away from the beam centerline, with maximum offset of 15 inches. For the top flange width of 34 inches, check negative moments at a location 11.33 inches away from beam centerline. (Note that this differs from the design section chosen for the deck reinforcement tables, which are conservatively based on M-series beams with 30 inch flanges.) The design is based on a unit strip one foot wide.

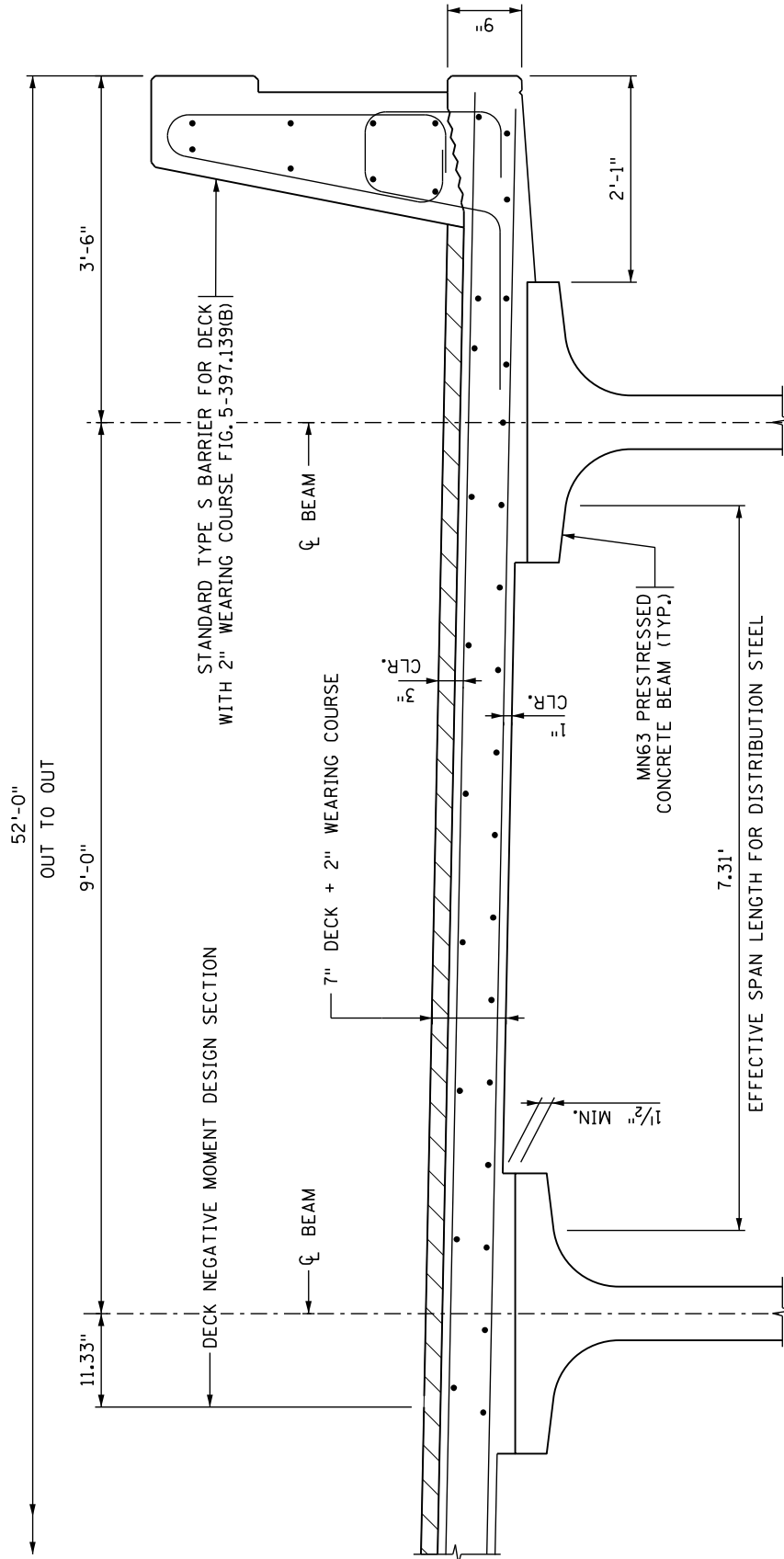

PARTIAL DECK SECTION

Figure 9.3.1

**C. Live Loads**  
**[Appendix A4]**

The AASHTO LRFD Specifications contain tables listing the design live load moments (positive and negative) for decks supported on different beam spacings. The tabularized moments are for a one foot wide strip.

The limitations for use of the tables include a check on the overhang dimension. A minimum of 1.75 feet from the centerline of the fascia beam is permitted. The maximum overhang permitted,  $L_{ohmax}$ , is the lesser of:

$$L_{ohmax} = 6.00 \text{ ft}$$

or

$$L_{ohmax} = 0.625 \cdot L_s = 0.625 \cdot 9.00 = 5.63 \text{ ft} \quad \text{GOVERNS}$$

For this example the overhang check falls within the limits:

$$1.75 \text{ ft} < 3.50 \text{ ft} < 5.63 \text{ ft} \quad \text{OK}$$

The overhang dimension checks are satisfied, as are all other parameters specified for use of the design live load moment tables.

**Interpolate Design Live Load Moments**

LRFD Table A4-1 lists the following design live load moments for a beam spacing of 9.0 ft:

$$\text{Positive moment} = 6.29 \text{ kip-ft}$$

$$\text{Negative moment (9 in)} = 4.28 \text{ kip-ft}$$

$$\text{Negative moment (12 in)} = 3.71 \text{ kip-ft}$$

Interpolate to obtain the negative moment at the design section (11.33 inches away from the center of the supporting beam):

$$M_{LL(neg)} = 4.28 - \left( \frac{11.33 - 9}{12 - 9} \right) \cdot (4.28 - 3.71) = 3.84 \text{ kip-ft}$$

The values in LRFD Table A4 -1 include the multiple presence and dynamic load allowance factors.

**D. Dead Loads**

The dead load moments are based on the self-weight of the 7 inch partial depth deck, the 2 inch wearing course, and a 0.020 ksf future wearing surface.

$$\text{Depth of concrete deck, } d_{deck} = 7 + 2 = 9 \text{ in}$$

Dead loads will be computed for a strip of deck 1 foot wide. MnDOT practice is to simplify the dead load bending moment calculations by computing both the positive and negative dead load bending moments using:

$$M_{DC} = \frac{W_{DC} \cdot L_s^2}{10}$$

Deck and Wearing Course Load:

$$W_{deck} = w_c \cdot d_{deck} = (0.150) \cdot 9 \cdot \frac{1}{12} = 0.11 \text{ klf}$$

Future Wearing Surface Load:

$$W_{fws} = 0.02 \text{ klf}$$

Combined Dead Load:

$$W_{DC} = W_{deck} + W_{fws} = 0.11 + 0.02 = 0.13 \text{ klf}$$

Dead Load Bending Moment:

$$M_{DC} = \frac{0.13 \cdot 9^2}{10} = 1.05 \text{ kip-ft}$$

**E. Flexural Design Moments**  
**[1.3.3 – 1.3.5]**

The load modifiers for the deck design are:

$$\begin{aligned} \eta_D &= 1.00 \\ \eta_R &= 1.00 \\ \eta_I &= 1.00 \end{aligned}$$

$$\text{Then } \eta_{cum} = \eta_D \cdot \eta_R \cdot \eta_I = 1.00$$

**[Table 3.4.1-1]**

Use the load factors provided in LRFD Article 3.4.1 to generate the Strength I and Service I design moments.

**Strength I Limit State Loads**

$$U_1 = \eta_{cum} \cdot (1.25 \cdot DC + 1.75 \cdot LL)$$

Negative Design Moment:

$$M_{u(neg)} = 1.00 \cdot [1.25 \cdot (1.05) + 1.75 \cdot (3.84)] = 8.03 \text{ kip-ft}$$

Positive Design Moment:

$$M_{u(pos)} = 1.00 \cdot [1.25 \cdot (1.05) + 1.75 \cdot (6.29)] = 12.32 \text{ kip-ft}$$

**Service I Limit State Loads**

$$S_1 = \eta_{cum} \cdot (1.0 \cdot DC + 1.0 \cdot LL)$$

Negative Design Moment:

$$M_{s(neg)} = 1.00 \cdot [1.0 \cdot (1.05) + 1.0 \cdot (3.84)] = 4.89 \text{ kip-ft}$$



Positive Design Moment:

$$M_{s(pos)} = 1.00 \cdot [1.0 \cdot (1.05) + 1.0 \cdot (6.29)] = 7.34 \text{ kip-ft}$$

**F. Top Steel  
(Negative  
Moment)**

[5.6.3]

**Flexure Strength Check**

The top reinforcement has a clear cover of 3 inches (which includes the 2 inch wearing course). Design the negative moment reinforcement assuming a singly reinforced cross section.

[5.5.4.2]

Assume the section is tension-controlled and the flexural resistance factor,  $\phi = 0.90$ .

Based on BDM Table 9.2.1.1, try #4 bars with a 6 inch center-to-center spacing.

Determine depth,  $d_s$ , from extreme compression fiber to tension reinforcement.

$$d_s = d_{deck} - \text{cover} - \frac{1}{2} \cdot d_b = 9 - 3 - \frac{1}{2} \cdot 0.5 = 5.75 \text{ in}$$

Width of compression face of member,  $b = 12 \text{ in}$

Area of top steel provided is:

$$A_{s(top)} = A_b \cdot \left( \frac{12}{\text{bar spacing}} \right) = 0.20 \cdot \left( \frac{12}{6} \right) = 0.40 \frac{\text{in}^2}{\text{ft}}$$

Then:

$$a = c \cdot \beta_1 = \frac{A_{s(top)} \cdot f_y}{0.85 \cdot f'_c \cdot b} = \frac{0.40 \cdot 60}{0.85 \cdot 4 \cdot 12} = 0.59 \text{ in}$$

$$\begin{aligned} \phi \cdot M_n &= \phi \cdot A_{s(top)} \cdot f_y \cdot \left( d_s - \frac{a}{2} \right) = 0.9 \cdot 0.40 \cdot 60 \cdot \left( 5.75 - \frac{0.59}{2} \right) \cdot \frac{1}{12} \\ &= 9.82 \text{ kip-ft} > 8.03 \text{ kip-ft} \quad \text{OK} \end{aligned}$$

[5.5.4.2]

Validate the assumption of 0.9 for resistance factor:

Calculate the depth of the section in compression:

$$c = \frac{a}{\beta_1} = \frac{0.59}{0.85} = 0.69 \text{ in}$$

[5.6.2.1]

Concrete compression strain limit  $\epsilon_c = 0.003$

Reinforcement tension-controlled strain limit  $\epsilon_{tl} = 0.005$

$$\epsilon_t = (d_s - c) \cdot \left(\frac{\epsilon_c}{c}\right) = (5.75 - 0.69) \cdot \left(\frac{0.003}{0.69}\right) = 0.0220 > \epsilon_{tl} = 0.005$$

Therefore,  $\phi = 0.9$

[5.6.7]

**Crack Control Check**

The LRFD crack control check places a limit on the spacing of reinforcement to prevent severe and excessive flexural cracking. This is accomplished by limiting the spacing of reinforcing bars as follows:

$$s \leq \frac{700 \cdot \gamma_e}{\beta_s \cdot f_{ss}} - 2 \cdot d_c$$

Also, the stress in the reinforcement,  $f_{ss}$ , is limited to:

$$f_{ss} \leq 0.6 \cdot f_y = 0.6 \cdot 60 = 36.0 \text{ ksi}$$

Per Article 5.3.2 of this manual, use a maximum clear cover of 2.0 inches to compute  $d_c$ . Assuming #4 bars are used:

$$d_c = 2.0 + 0.5 \cdot d_b = 2.0 + 0.5 \cdot 0.50 = 2.25 \text{ in}$$

The stress in the reinforcement is found using a cracked section analysis with the trial reinforcement. To simplify the calculation, the section is assumed to be singly reinforced.

[5.4.2.4 & 5.6.1]

Referring to Figure 9.3.2, determine the distance,  $x$ , from the bottom of the deck to the neutral axis:

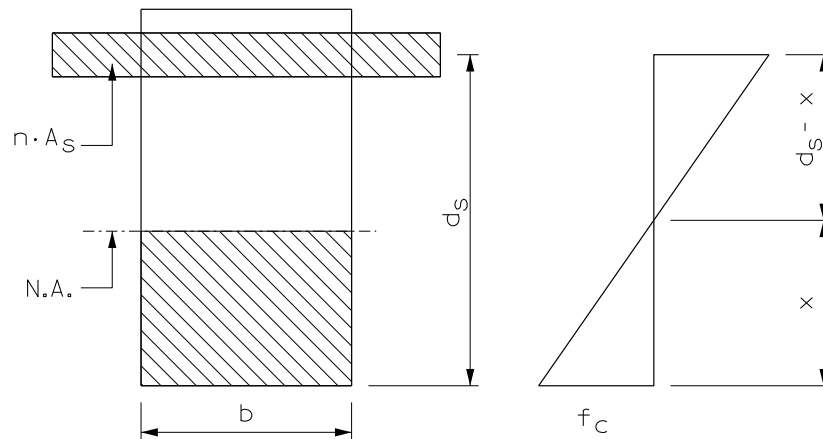

Figure 9.3.2

$$n = \frac{E_s}{E_c} = \frac{29,000}{120,000 \cdot K_1 \cdot w_{CE}^2 \cdot f_c^{0.33}} = \frac{29,000}{120,000 \cdot 1.0 \cdot 0.145^2 \cdot 4^{0.33}} = 7.27$$

$$n \cdot A_s = 7.27 \cdot 0.40 = 2.908$$

$$b \cdot x \cdot \frac{x}{2} = n \cdot A_s \cdot (d_s - x)$$

$$\frac{12 \cdot x^2}{2} = 2.908 \cdot (5.75 - x)$$

solving,  $x = 1.44$  in

Determine the lever arm between service load flexural force components:

$$j \cdot d_s = d_s - \frac{x}{3} = 5.75 - \frac{1.44}{3} = 5.27 \text{ in}$$

The stress in the reinforcement when subjected to the Service I moment is:

$$f_{ss} = \frac{M_{s(neg)}}{A_s \cdot j \cdot d_s} = \frac{4.89 \cdot 12}{0.40 \cdot 5.27} = 27.8 \text{ ksi} < 36.0 \text{ ksi} \quad \text{OK}$$

Find  $\beta_s$ . For determination of deck depth,  $h$ , conservatively assume 0.5 inches of wear:

$$h = d_{deck} - 0.5 = 9 - 0.5 = 8.5 \text{ in}$$

$$\beta_s = 1 + \frac{d_c}{0.7 \cdot (h - d_c)} = 1 + \frac{2.25}{0.7 \cdot (8.5 - 2.25)} = 1.51$$

For severe exposure, use  $\gamma_e=0.75$ . Then, maximum bar spacing,  $s_{max}$ , is:

$$s_{max} = \frac{700 \cdot \gamma_e}{\beta_s \cdot f_{ss}} - 2 \cdot d_c = \frac{700 \cdot 0.75}{1.51 \cdot 27.8} - 2 \cdot 2.25 = 8.01 \text{ in} > 6 \text{ in} \quad \text{OK}$$

**[5.6.3.3]**

**Minimum Reinforcement**

Check that reinforcement can carry the smaller of:

- Cracking moment,  $M_{cr}$
- $1.33 \cdot M_{u(neg)}$

Conservatively assume the full 9 inch deep section for the minimum reinforcement check:

$$S_{\text{deck}} = \frac{b \cdot (d_{\text{deck}})^2}{6} = \frac{12 \cdot 9^2}{6} = 162 \text{ in}^3$$

**[5.4.2.6]**

Determine the modulus of rupture,  $f_r$ :

$$\lambda = 1.0 \text{ for normal weight concrete}$$

$$f_r = 0.24 \cdot \lambda \cdot \sqrt{f'_c} = 0.24 \cdot 1.0 \cdot \sqrt{4} = 0.48 \text{ ksi}$$

Take  $\gamma_1 = 1.60$  and  $\gamma_3 = 0.67$  for ASTM Grade 60 reinforcement.

Combining these parameters results in a cracking moment,  $M_{cr}$ , of:

$$M_{cr} = \gamma_3 \cdot \gamma_1 \cdot f_r \cdot S_{\text{deck}} = 0.67 \cdot 1.60 \cdot 0.48 \cdot 162 \cdot \frac{1}{12} = 6.95 \text{ kip-ft}$$

Compare this to:

$$1.33 \cdot M_{u(\text{neg})} = 1.33 \cdot 8.03 = 10.68 \text{ kip-ft} > 6.95 \text{ kip-ft}$$

Use the  $M_{cr}$  value to check minimum reinforcement.

$$\phi \cdot M_n = 9.82 \text{ kip-ft} > 6.95 \text{ kip-ft} \quad \text{OK}$$

**G. Bottom Steel  
(Positive Moment)  
[5.6.3]**

**Flexure Strength Check**

The bottom reinforcement has a clear cover of one inch. Because the wearing course may be removed in future milling operations, do not include it in structural capacity computations. Design the positive moment reinforcement assuming a singly reinforced cross section.

**[5.5.4.2]**

Assume the section is controlled in tension and the flexural resistance factor,  $\phi = 0.90$ .

Based on BDM Table 9.2.1.1, try #5 bars with a 7 inch center-to-center spacing.

Determine the depth,  $d_s$ , from extreme compression fiber to tension reinforcement.

$$d_s = d_{\text{deck}} - \text{cover} - \text{wear course} - \frac{1}{2} \cdot d_b = 9 - 1 - 2 - \frac{1}{2} \cdot 0.63 = 5.69 \text{ in}$$

Width of compression face of member,  $b = 12 \text{ in}$

Area of top steel provided is:

$$A_{s(\text{bot})} = A_b \cdot \left( \frac{12}{\text{bar spacing}} \right) = 0.31 \cdot \left( \frac{12}{7} \right) = 0.53 \frac{\text{in}^2}{\text{ft}}$$

Then:

$$a = c \cdot \beta_1 = \frac{A_{s(\text{bot})} \cdot f_y}{0.85 \cdot f_c \cdot b} = \frac{0.53 \cdot 60}{0.85 \cdot 4 \cdot 12} = 0.78 \text{ in}$$

$$\begin{aligned} \phi \cdot M_n &= \phi \cdot A_{s(\text{bot})} \cdot f_y \cdot \left( d_s - \frac{a}{2} \right) = 0.9 \cdot 0.53 \cdot 60 \cdot \left( 5.69 - \frac{0.78}{2} \right) \cdot \frac{1}{12} \\ &= 12.64 \text{ kip-ft} > 12.32 \text{ kip-ft} \quad \text{OK} \end{aligned}$$

#### [5.5.4.2]

Validate the assumption of 0.9 for resistance factor:

Calculate the depth of the section in compression:

$$c = \frac{a}{\beta_1} = \frac{0.78}{0.85} = 0.92 \text{ in}$$

Concrete compression strain limit  $\epsilon_c = 0.003$

Reinforcement tension-controlled strain limit  $\epsilon_{tl} = 0.005$

$$\epsilon_t = (d_s - c) \cdot \left( \frac{\epsilon_c}{c} \right) = (5.69 - 0.92) \cdot \left( \frac{0.003}{0.92} \right) = 0.0156 > \epsilon_{tl} = 0.005$$

Therefore,  $\phi = 0.9$

#### [5.6.7]

##### Crack Control Check

As noted previously, the limit on spacing of reinforcement for crack control is:

$$s \leq \frac{700 \cdot \gamma_e}{\beta_s \cdot f_{ss}} - 2 \cdot d_c$$

Also, the stress in the reinforcement,  $f_{ss}$ , is limited to:

$$f_{ss} \leq 0.6 \cdot f_y = 0.6 \cdot 60 = 36.0 \text{ ksi}$$

For #5 bars with 1 inch of cover,  $d_c$  is:

$$d_c = \text{cover} + 0.5 \cdot d_b = 1.00 + 0.5 \cdot 0.625 = 1.31 \text{ in}$$

Compute the stress in the reinforcement using a cracked section analysis of a singly reinforced section. Begin by locating the neutral axis.

As calculated previously,  $n = 7.27$

$$n \cdot A_s = 7.27 \cdot 0.53 = 3.853$$

$$b \cdot x \cdot \frac{x}{2} = n \cdot A_s \cdot (d_s - x)$$

$$\frac{12 \cdot x^2}{2} = 3.853 \cdot (5.69 - x)$$

solving,  $x = 1.62$  in

Determine the lever arm between service load flexural force components.

$$j \cdot d_s = d_s - \frac{x}{3} = 5.69 - \frac{1.62}{3} = 5.15 \text{ in}$$

The stress in the reinforcement when subjected to the Service I design moment is:

$$f_{ss} = \frac{M_{s(\text{pos})}}{A_s \cdot j \cdot d_s} = \frac{7.34 \cdot 12}{0.53 \cdot 5.15} = 32.3 \text{ ksi} < 36.0 \text{ ksi} \quad \text{OK}$$

Find  $\beta_s$ . For determination of deck depth,  $h$ , conservatively ignore the 2 inch wearing course:

$$h = d_{\text{deck}} - 2.0 = 9 - 2 = 7.0 \text{ in}$$

$$\beta_s = 1 + \frac{d_c}{0.7 \cdot (h - d_c)} = 1 + \frac{1.31}{0.7 \cdot (7.0 - 1.31)} = 1.33$$

For severe exposure, use  $\gamma_e = 0.75$ . Then, maximum bar spacing,  $s_{\text{max}}$ , is:

$$s_{\text{max}} = \frac{700 \cdot \gamma_e}{\beta_s \cdot f_{ss}} - 2 \cdot d_c = \frac{700 \cdot 0.75}{1.33 \cdot 32.3} - 2 \cdot 1.31 = 9.60 \text{ in} > 7 \text{ in} \quad \text{OK}$$

**[5.6.3.3]**

**Minimum Reinforcement Check**

Check that reinforcement can carry the smaller of:

- Cracking moment,  $M_{cr}$
- $1.33 \cdot M_{u(\text{neg})}$

Conservatively assuming the full 9 inch deep section for the minimum reinforcement check,  $S = 162 \text{ in}^3$  (previously calculated).

**[5.4.2.6]**

Also, the modulus of rupture,  $f_r = 0.48 \text{ ksi}$  (previously calculated)

Taking  $\gamma_1 = 1.60$  and  $\gamma_3 = 0.67$  for ASTM Grade 60 reinforcement, the cracking moment,  $M_{cr}$ , is:

$$M_{cr} = \gamma_3 \cdot \gamma_1 \cdot f_r \cdot S_{deck} = 0.67 \cdot 1.60 \cdot 0.48 \cdot 162 \cdot \frac{1}{12} = 6.95 \text{ kip-ft}$$

Compare this to:

$$1.33 \cdot M_{u(pos)} = 1.33 \cdot 12.32 = 16.39 \text{ kip-ft} > 6.95 \text{ kip-ft}$$

Use the  $M_{cr}$  value to check minimum reinforcement.

$$\phi \cdot M_n = 12.65 \text{ kip-ft} > 6.95 \text{ kip-ft} \quad \text{OK}$$

**H. Bottom  
Longitudinal  
Reinforcement**

**[9.7.3.2]**

As part of the Traditional Design Method an “equivalent width method” for reinforced bridge deck designs is utilized. To ensure proper load distribution, reinforcement placed perpendicular to the primary reinforcement must be provided in the bottom mat. This reinforcement is a fraction of the primary steel required for positive moment. For decks where the primary reinforcement is placed perpendicular to traffic, the longitudinal reinforcement requirement in the bottom mat is:

$$PCT = \left( \frac{220}{\sqrt{S_e}} \right) \leq 67\%$$

where  $S_e$  is the effective span length in feet

**[9.7.2.3]**

The effective span length is a function of the beam spacing and type of beam. For prestressed concrete I-beam sections, the effective span length,  $S_e$ , is:

$$\begin{aligned} S_e &= \text{beam spacing} - \text{top flange width} + \text{one flange overhang} \\ &= 9.00 - \frac{34}{12} + \frac{13.75}{12} = 7.31 \text{ ft} \end{aligned}$$

$$PCT = \left( \frac{220}{\sqrt{S_e}} \right) = \left( \frac{220}{\sqrt{7.31}} \right) = 82.6\% \geq 67\%$$

Use 67% of the primary steel in the bottom mat.

The required area of steel is:

$$A_{s(req)} = 0.67 \cdot A_{s(bot)} = 0.67 \cdot 0.53 = 0.36 \text{ in}^2/\text{ft}$$

Try #5 bars on 10 inch centers. Area of steel provided equals:

$$A_{s(prov)} = A_b \cdot \left( \frac{12}{\text{spacing}} \right) = 0.31 \cdot \left( \frac{12}{10} \right) = 0.37 \frac{\text{in}^2}{\text{ft}} > 0.36 \frac{\text{in}^2}{\text{ft}} \quad \text{OK}$$

***I. Top Longitudinal Reinforcement***  
***[5.10.6]***

The top longitudinal bars must meet the shrinkage and temperature reinforcement requirements.

The least width  $b = b_{deck} = 624$  in

Take the least depth,  $h$ , as equal to the full deck thickness (conservative), which is 9 inches.

Then:

$$A_{stemp} \geq \frac{1.30 \cdot b \cdot h}{2 \cdot (b + h) \cdot f_y} = \frac{1.30 \cdot 624 \cdot 9}{2 \cdot (624 + 9) \cdot 60} = 0.096 \frac{\text{in}^2}{\text{ft}}$$

In addition:

$$0.11 \text{ in}^2/\text{ft} \leq A_{stemp} \leq 0.60 \text{ in}^2/\text{ft}$$

and

maximum bar spacing is 18 inches

Therefore, use #4 bars spaced at 18 inches ( $A_s = 0.13 \text{ in}^2/\text{ft}$ ) for the top longitudinal reinforcement.

MnDOT includes additional reinforcement over the piers when the deck is continuous, but the beams are not continuous. The additional reinforcing consists of two #6 bars placed on 6 inch centers between the top mat #4 bars. Refer to Figure 9.2.1.8 for typical reinforcement detailing.

Figure 9.3.3 illustrates the final reinforcement layout for the interior region of the deck.

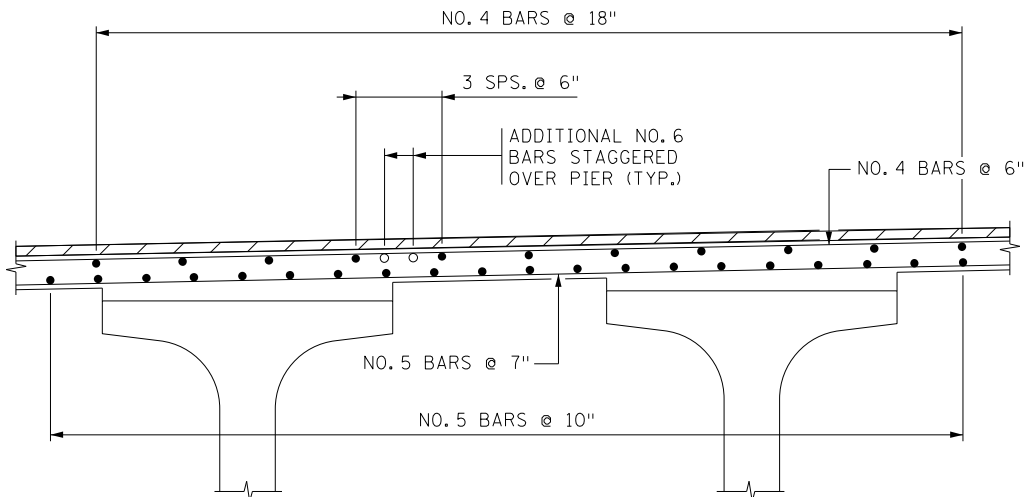

**Figure 9.3.3**



**J. Structural Analysis of Deck Overhang Region [A13.4.1]**

Figure 9.3.4 illustrates the deck overhang region. Four cases must be considered for the deck overhang design:

- Case 1: Extreme Event II evaluated at the toe of the barrier for the dead load plus horizontal collision force.
- Case 2: Extreme Event II evaluated at the edge of the beam flange for the dead load plus horizontal collision force plus live load.
- Case 3: Strength I evaluated at the edge of the beam flange for the dead load plus live load.
- Case 4: Extreme Event II evaluated at the edge of the beam flange for the dead load plus vertical collision force plus live load.

For this example, the distance from the edge of flange to the gutter line is less than 1 foot, so a live load wheel load is not considered. Also, the dead load moment is a small fraction of the moment due to the collision load, so the higher Strength I load factor for dead load does not have an appreciable effect on the Strength I load combination when comparing it to Extreme Event II. Therefore, by inspection, Case 3 will not govern over Cases 1 and 2, so Case 3 calculations are not included in this example.

**K. Overhang Region Analysis, Case 1**

**Geometry and Loads**

Case 1 is Extreme Event II checked at the toe of the barrier for dead load and the horizontal collision force. Referring to Figure 9.3.4, determine the center of gravity location for the barrier by considering the area of a rectangular block that encompasses the entire barrier cross-section and subtracting components ①, ②, and ③. Results are shown in Table 9.3.1:

**Table 9.3.1 Determination of Barrier Center of Gravity Location**

| Component Description      | Width (in) | Height (in) | Area (in <sup>2</sup> ) | Moment Arm From Barrier Toe (in) | Area · Moment Arm (in <sup>3</sup> ) |
|----------------------------|------------|-------------|-------------------------|----------------------------------|--------------------------------------|
| Block encompassing barrier | 18.38      | 38.00       | 698.44                  | 9.19                             | 6418.66                              |
| ① (triangle)               | 7.38       | 38.00       | -140.22                 | 2.46                             | -344.94                              |
| ② (rectangle)              | 2.00       | 25.00       | -50.00                  | 17.38                            | -869.00                              |
| ③ (triangle)               | 16.38      | 2.00        | -16.38                  | 10.92                            | -178.87                              |

Total = 491.84 in<sup>2</sup>

Total = 5025.85 in<sup>3</sup>

Then C.G. location,  $x_{cg}$ , from barrier toe is:  $x_{cg} = \frac{5025.85}{491.84} = 10.22 \text{ in}$

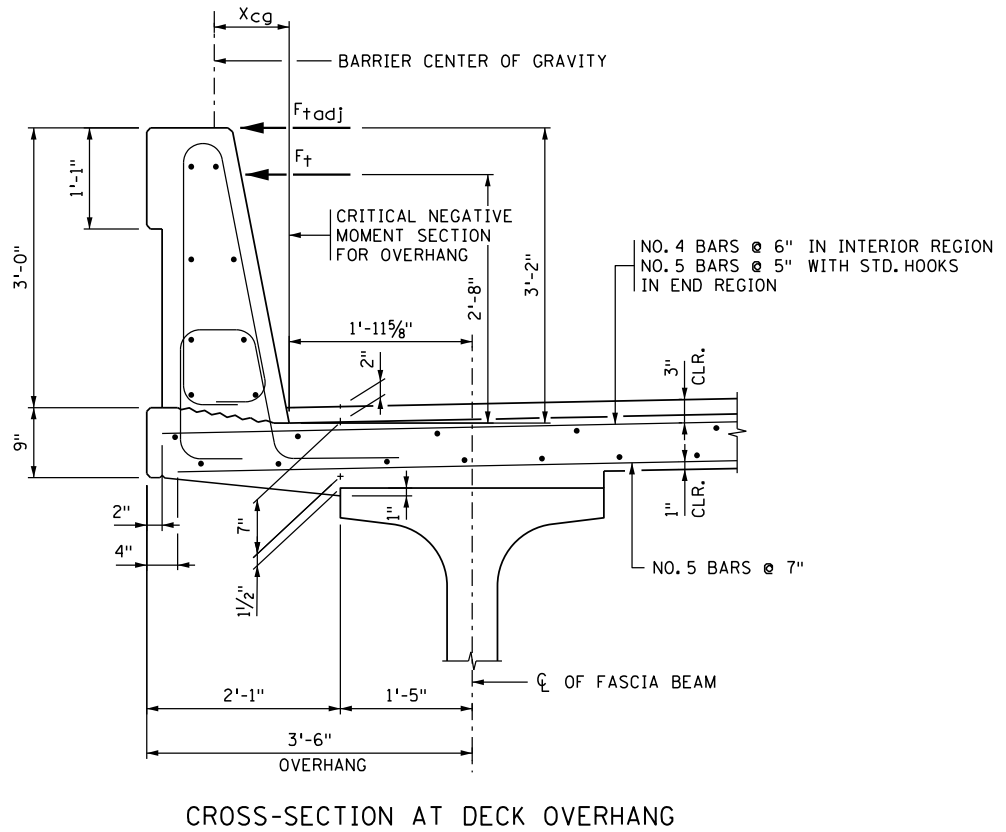
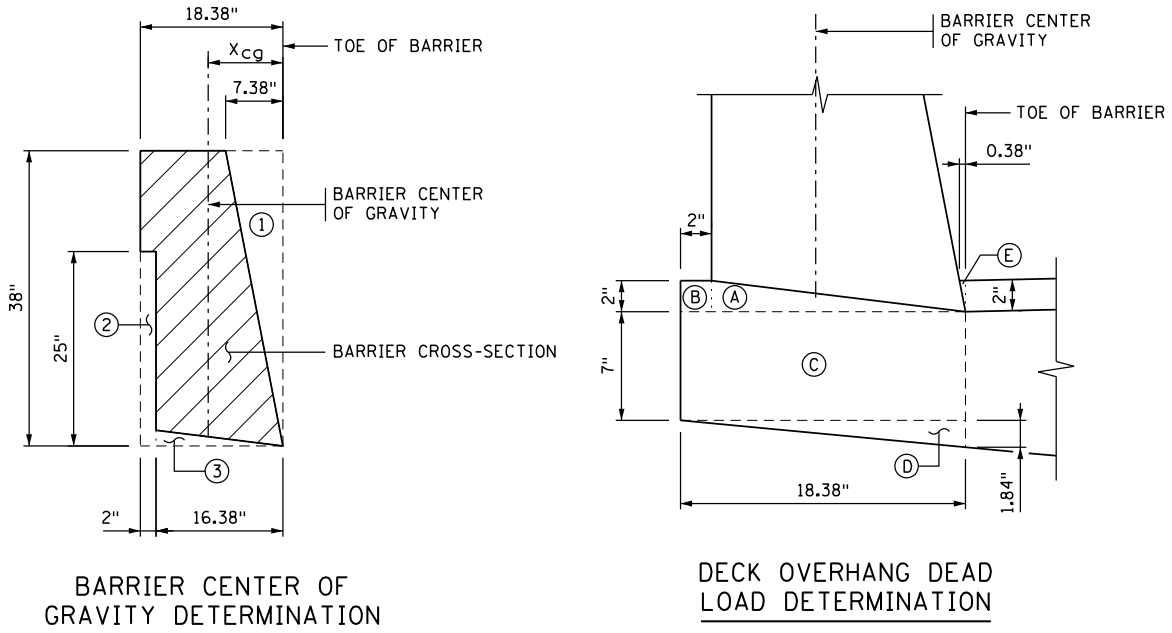

Figure 9.3.4

Overhang = 3.50 ft = 42 in

Distance from centerline of beam to edge of top flange = 17 in

Edge of deck to critical negative moment section at barrier toe,

$$L_{crit} = 18.38 \text{ in}$$

Deck thickness,  $h_{deck\_toe}$ , at barrier toe (ignoring wearing course):

$$h_{deck\_toe} = (9 - 2) + \left( \frac{18.38}{42 - 17} \right) \cdot [(2 + 7 + 1.5 + 1) - 9] = 8.84 \text{ in}$$

Referring again to Figure 9.3.4, determine dead load moments acting on the deck at the toe of barrier. Results are shown in Table 9.3.2:

**Table 9.3.2 Determination of Dead Load Moments at Barrier Toe for a 1 ft. Deck Strip Width**

| Component Description | Width (in) | Height (in) | $w_{DC}$ (kips) | Moment Arm From Barrier Toe (in) | Unfactored Moment $M_{DC}$ (kip-ft) |
|-----------------------|------------|-------------|-----------------|----------------------------------|-------------------------------------|
| Barrier               |            |             | 0.513           | 10.22                            | 0.437                               |
| (A) (triangle)        | 16.38      | 2.00        | 0.017           | 10.92                            | 0.015                               |
| (B) (rectangle)       | 2.00       | 2.00        | 0.004           | 17.38                            | 0.006                               |
| (C) (rectangle)       | 18.38      | 7.00        | 0.134           | 9.19                             | 0.103                               |
| (D) (triangle)        | 18.38      | 1.84        | 0.018           | 6.13                             | 0.009                               |
| (E) (triangle)        | 0.38       | 2.00        | 0.000           | 0.13                             | 0.000                               |

Total  $w_{DC}$  = 0.686 kips for 1 ft strip width

Total  $M_{DC}$  = 0.570 kip-ft for a 1 ft strip width

**[A13.2]**

**Collision Force Tension and Bending Moment**

Using the yield line analysis method of LRFD Appendix A13, values for the nominal resistance,  $R_w$ , flexural resistance about the horizontal axis,  $M_c$ , and critical wall length,  $L_c$ , were calculated (not included here) for a 36 inch Type S barrier mounted on a deck that includes a wearing course (Std. Figure 5-397.139(B)):

Barrier int.:  $R_{w\_int} = 117.4$  kips     $M_{c\_int} = 17.1$  kip-ft/ft     $L_{c\_int} = 10.9$  ft

Barrier end:  $R_{w\_end} = 71.8$  kips     $M_{c\_end} = 22.8$  kip-ft/ft     $L_{c\_end} = 5.0$  ft

For a barrier meeting NCHRP Report 350 Test Level 4:

Transverse collision load  $F_t = 54$  kips

Height of load application  $H_e = 32$  in (distance above top of wearing course)

Because the yield line equations in LRFD assume the collision load is applied at the top of the barrier, adjust  $F_t$  for the difference between the

barrier height and height of application. Refer to Figure 9.3.4. Note that the barrier sits on the partial depth deck with its toe 2 inches below the top of wearing course:

$$H_{\text{barrier}} = 38 \text{ in}$$

$$F_{\text{tadj}} = F_t \cdot \left( \frac{H_e + 2}{H_{\text{barrier}}} \right) = 54 \cdot \left( \frac{32 + 2}{38} \right) = 48.3 \text{ kips}$$

Because the barrier capacity can be excessively large compared to the collision load, MnDOT requires that the deck overhang be designed to resist a transverse collision force equal to the lesser of the barrier capacity  $R_w$  or  $\frac{4}{3} \cdot F_{\text{tadj}}$ :

$$F_{\text{coll\_int}} = R_{w\_int} = 117.4 \text{ kips}$$

$$F_{\text{coll\_end}} = R_{w\_end} = 71.8 \text{ kips}$$

or

$$= \frac{4}{3} \cdot F_{\text{tadj}} = \frac{4}{3} \cdot 48.3 = 64.4 \text{ kips} \quad \text{GOVERNS IN BOTH REGIONS}$$

Since  $R_{w\_int}$  and  $R_{w\_end}$  do not govern, the  $M_c$  values must also be adjusted to correspond with the collision load:

$$M_{\text{cadj\_int}} = \frac{F_{\text{coll\_int}}}{R_{w\_int}} \cdot M_{c\_int} = \frac{64.4}{117.4} \cdot 17.1 = 9.4 \frac{\text{kip-ft}}{\text{ft}}$$

$$M_{\text{cadj\_end}} = \frac{F_{\text{coll\_end}}}{R_{w\_end}} \cdot M_{c\_end} = \frac{64.4}{71.8} \cdot 22.8 = 20.5 \frac{\text{kip-ft}}{\text{ft}}$$

For deck overhang design, assume that the collision load is distributed over a length of  $L_{c\_int} + 2 \cdot H_{\text{barrier}}$  for the interior overhang region and  $L_{c\_end} + H_{\text{barrier}}$  for the end overhang region. Then:

$$F_{\text{cadj\_int}} = \frac{F_{\text{coll\_int}}}{L_{c\_int} + 2 \cdot H_{\text{barrier}}} = \frac{64.4}{10.9 + 2 \cdot \frac{38}{12}} = 3.7 \text{ kips/ft}$$

$$F_{\text{cadj\_end}} = \frac{F_{\text{coll\_end}}}{L_{c\_end} + H_{\text{barrier}}} = \frac{64.4}{5.0 + \frac{38}{12}} = 7.9 \text{ kips/ft}$$

The resulting load  $M_{\text{cadj}}$  is located at the top of the partial depth deck at the toe of the barrier. Translate this load to the center of the partial depth deck for design of the deck overhang. Referring to Figure 9.3.5, first find the eccentricity:

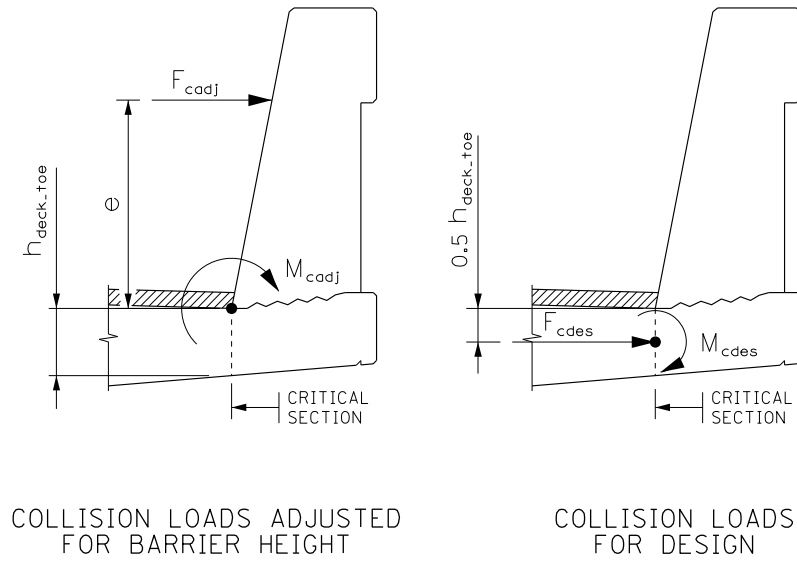

Figure 9.3.5

$$e_{int} = \frac{M_{cadj\_int}}{F_{cadj\_int}} = \frac{9.4}{3.7} = 2.54 \text{ ft}$$

$$e_{end} = \frac{M_{cadj\_end}}{F_{cadj\_end}} = \frac{20.5}{7.9} = 2.59 \text{ ft}$$

Then:

$$F_{cdes\_int} = F_{cadj\_int} = 3.7 \text{ kips/ft}$$

$$\begin{aligned} M_{cdes\_int} &= F_{cdes\_int} \cdot (e_{int} + 0.5 \cdot h_{deck\_toe}) \\ &= 3.7 \cdot \left( 2.54 + 0.5 \cdot \frac{8.84}{12} \right) = 10.8 \frac{\text{kip-ft}}{\text{ft}} \end{aligned}$$

$$F_{cdes\_end} = F_{cadj\_end} = 7.9 \text{ kips/ft}$$

$$\begin{aligned} M_{cdes\_end} &= F_{cdes\_end} \cdot (e_{end} + 0.5 \cdot h_{deck\_toe}) \\ &= 7.9 \cdot \left( 2.59 + 0.5 \cdot \frac{8.84}{12} \right) = 23.4 \frac{\text{kip-ft}}{\text{ft}} \end{aligned}$$

**Extreme Event II Limit State Bending Moment**

Total factored loads are:

**[A13.4.1]**

$$\begin{aligned}M_{u\_int} &= 1.00 \cdot M_{DC} + 1.00 \cdot M_{cdes\_int} \\ &= 1.00 \cdot 0.57 + 1.00 \cdot 10.8 = 11.4 \text{ kip-ft/ft}\end{aligned}$$

$$\begin{aligned}P_{u\_int} &= 1.00 \cdot F_{DC} + 1.00 \cdot F_{cdes\_int} \\ &= 1.00 \cdot 0.0 + 1.00 \cdot 3.7 = 3.7 \text{ kips/ft}\end{aligned}$$

$$\begin{aligned}M_{u\_end} &= 1.00 \cdot M_{DC} + 1.00 \cdot M_{cdes\_end} \\ &= 1.00 \cdot 0.57 + 1.00 \cdot 23.4 = 24.0 \text{ kip-ft/ft}\end{aligned}$$

$$\begin{aligned}P_{u\_end} &= 1.00 \cdot F_{DC} + 1.00 \cdot F_{cdes\_end} \\ &= 1.00 \cdot 0.0 + 1.00 \cdot 7.9 = 7.9 \text{ kips/ft}\end{aligned}$$

The eccentricity of  $P_u$  is:

$$e_{u\_int} = \frac{M_{u\_int}}{P_{u\_int}} = \frac{11.4}{3.7} = 3.08 \text{ ft} = 36.96 \text{ in}$$

$$e_{u\_end} = \frac{M_{u\_end}}{P_{u\_end}} = \frac{24.0}{7.9} = 3.04 \text{ ft} = 36.48 \text{ in}$$

**Resistance of Deck Interior Overhang Region**

The overhang must resist both axial tension and bending moment. The capacity of the overhang will be determined by considering the tension side of the structural interaction diagram for a one foot wide portion of the overhang. See Figure 9.3.6.

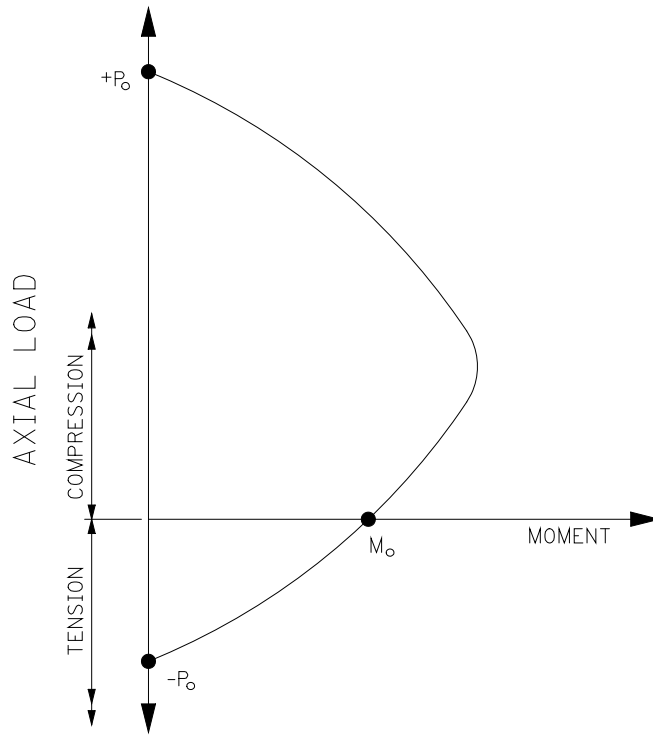

STRUCTURAL INTERACTION DIAGRAM

**Figure 9.3.6**

Check if the reinforcement chosen for the deck interior region (between the fascia beams) will be adequate for the overhang. The deck interior region reinforcement is:

Top reinforcement - #4 bars @ 6" ( $A_{s(top)} = 0.40 \text{ in}^2/\text{ft}$ )

Bottom reinforcement - #5 bars @ 7" ( $A_{s(bot)} = 0.53 \text{ in}^2/\text{ft}$ )

Note that the front leg of the barrier bar also contributes to the strength of the overhang. The barrier reinforcement is:

Barrier front leg - #5 bars @ 12" ( $A_{s(bar)} = 0.31 \text{ in}^2/\text{ft}$ )

Referring to Figure 9.3.7, determine the capacity of the overhang section for the eccentricity  $e_{u\_int}$  equal to 36.96 inches.

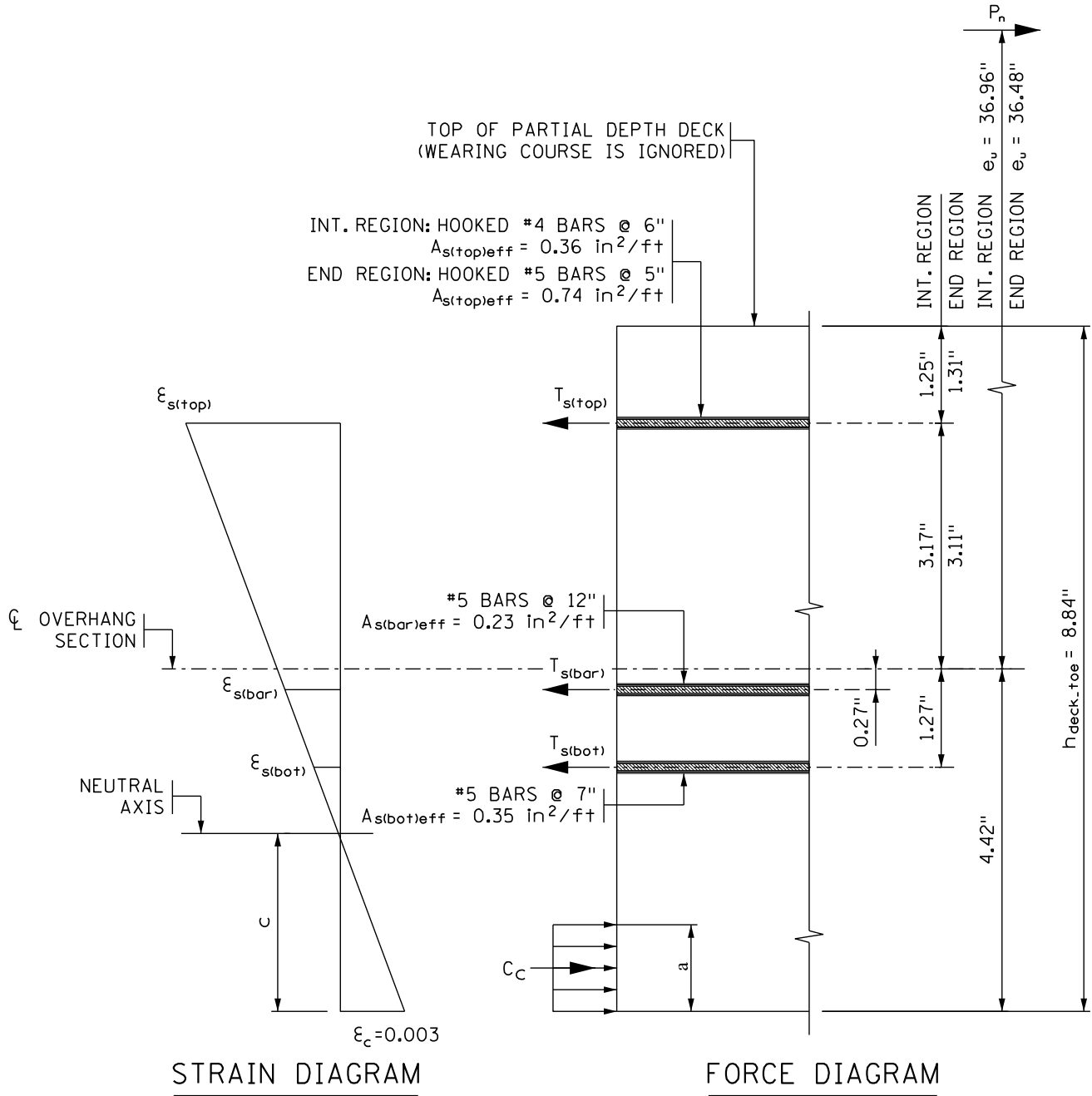

**Reinforced Concrete Section at Toe of Barrier**  
**Figure 9.3.7**

First, determine the effective area of reinforcement for the deck bars located at the toe of the barrier. From Figure 5.2.2.2 of this manual, the development length,  $l_d$ , for the deck bars are as follows:

For #4 top bars @ 6", cover is > 3" outside barrier toe, which results in an  $l_d = 18"$ .

For #5 bottom bars @ 7", cover varies with 1" minimum.



Using the 1" minimum cover results in an  $\ell_d = 33"$ .

For #5 barrier bars @ 12", minimum cover is 2.38" to the top of deck at the inside of the barrier toe (ignoring wearing course), which results in an  $\ell_d = 22"$ .

Then:

For #4 top bars,  $\ell_{d\text{available}} = L_{\text{crit}} - (\text{top bar end cover})$   
 $= 18.38 - 2.0 = 16.38 \text{ in}$

$$A_{s(\text{top})\text{eff}} = A_{s(\text{top})} \cdot \frac{\ell_{d\text{available}}}{\ell_d} = 0.40 \cdot \frac{16.38}{18} = 0.36 \frac{\text{in}^2}{\text{ft}}$$

For #5 bottom bars,  $\ell_{d\text{available}} = L_{\text{crit}} - (\text{bottom bar end cover})$   
 $= 18.38 - 4.0 = 14.38 \text{ in}$

$$A_{s(\text{bot})\text{eff}} = A_{s(\text{bot})} \cdot \frac{\ell_{d\text{available}}}{\ell_d} = 0.53 \cdot \frac{14.38}{33} = 0.23 \frac{\text{in}^2}{\text{ft}}$$

For #5 barrier bars (R501E), the bar is considered fully developed on the outside of the barrier toe due to the bend. On the traffic side of the barrier toe, refer to Figure 9.3.8 to determine how much of the 18" bar leg extends beyond the toe.

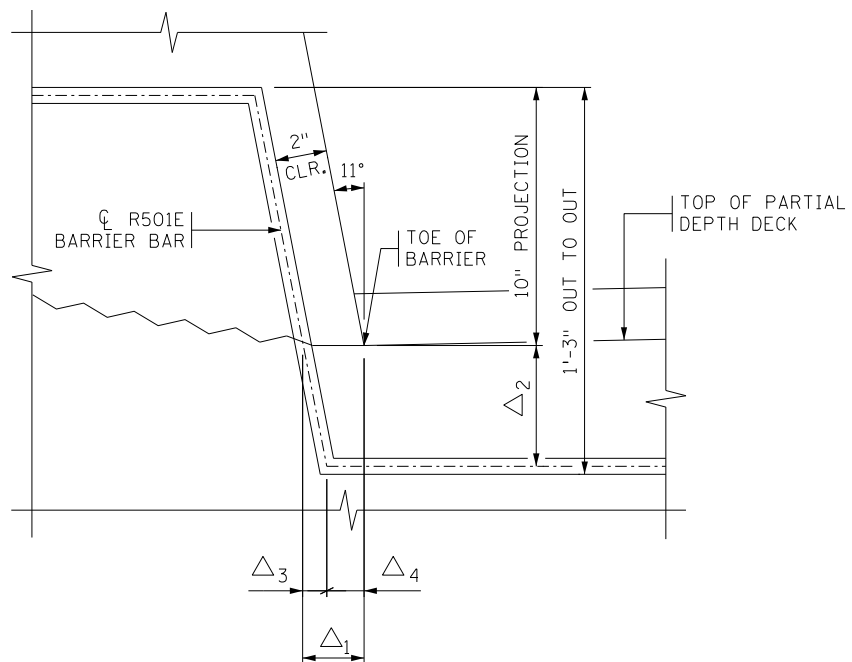

PARTIAL SECTION AT TOE OF BARRIER

Figure 9.3.8

$$\Delta_1 = \frac{2 + 0.5 \cdot (0.625)}{\cos 11^\circ} = 2.36 \text{ in}$$

$$\Delta_2 = 15 - 10 - 0.5 \cdot (0.625) = 4.69 \text{ in}$$

$$\Delta_3 = 4.69 \cdot (\tan 11^\circ) = 0.91 \text{ in}$$

$$\Delta_4 = 2.36 - 0.91 = 1.45 \text{ in}$$

Then:

$$\ell_{\text{davailable}} = 18 - 1.45 = 16.55 \text{ in}$$

$$A_{s(\text{bar})\text{eff}} = A_{s(\text{bar})} \cdot \frac{\ell_{\text{davailable}}}{\ell_d} = 0.31 \cdot \frac{16.55}{22} = 0.23 \frac{\text{in}^2}{\text{ft}}$$

Now determine the distance from the bottom of the section to the neutral axis,  $c$ . Start by assuming that for all reinforcement,  $\epsilon_s > \epsilon_y$ .

Then:

$$f_s = E_s \cdot \epsilon_y = f_y$$

$$T_{s(\text{top})} = A_{s(\text{top})\text{eff}} \cdot f_y = 0.36 \cdot 60 = 21.60 \text{ kips/ft}$$

$$T_{s(\text{bot})} = A_{s(\text{bot})\text{eff}} \cdot f_y = 0.23 \cdot 60 = 13.80 \text{ kips/ft}$$

$$T_{s(\text{bar})} = A_{s(\text{bar})\text{eff}} \cdot f_y = 0.23 \cdot 60 = 13.80 \text{ kips/ft}$$

$$T_{s(\text{tot})} = 21.60 + 21.00 + 13.80 = 49.20 \text{ kips/ft}$$

The total compression force  $C_c$  is:

$$C_c = 0.85 \cdot f'_c \cdot b \cdot a = 0.85 \cdot 4.0 \cdot 12.0 \cdot 0.85 \cdot c = 34.68 \cdot c$$

Referring to Figure 9.3.7, find  $c$  by taking moments about  $P_n$ :

$$\begin{aligned} & 21.60 \cdot (36.96 - 3.17) \\ & + 13.80 \cdot (36.96 + 1.27) \\ & + 13.80 \cdot (36.96 + 0.27) \\ & - 34.68 \cdot c \cdot (36.96 + 4.42 - 0.5 \cdot 0.85 \cdot c) = 0 \end{aligned}$$

Solving, we get  $c = 1.25 \text{ in}$

Check if original assumption was correct, that  $\epsilon_s > \epsilon_y$ :

$$\epsilon_y = \frac{f_y}{E_s} = \frac{60}{29,000} = 0.00207$$

$$\epsilon_{s(\text{top})} = (8.84 - 1.25 - 1.25) \cdot \left(\frac{0.003}{1.25}\right) = 0.01522 > 0.00207$$

$$\epsilon_{s(\text{bot})} = (4.42 - 1.27 - 1.25) \cdot \left(\frac{0.003}{1.25}\right) = 0.00456 > 0.00207$$

$$\epsilon_{s(\text{bar})} = (4.42 - 0.27 - 1.25) \cdot \left( \frac{0.003}{1.25} \right) = 0.00696 > 0.00207$$

Therefore the assumption was correct.

Then,

$$C_c = 34.68 \cdot c = 34.68 \cdot 1.25 = 43.35 \text{ kips/ft}$$

And,

$$\begin{aligned} P_n &= T_{s(\text{top})} + T_{s(\text{bot})} + T_{s(\text{bar})} - C_c \\ &= 21.60 + 13.80 + 13.80 - 43.35 = 5.85 \text{ kips/ft} \end{aligned}$$

### [1.3.2.1]

The resistance factor  $\phi$  for Extreme Event II limit state is 1.0. Therefore,

$$\phi \cdot P_n = 1.0 \cdot 5.85 = 5.85 \text{ kips/ft} > 3.7 \text{ kips/ft} \quad \text{OK}$$

$$\phi \cdot M_n = \phi \cdot P_n \cdot e_u$$

$$= 1.0 \cdot 5.85 \cdot 36.96 \cdot \frac{1}{12} = 18.02 \frac{\text{kip-ft}}{\text{ft}} > 11.4 \frac{\text{kip-ft}}{\text{ft}} \quad \text{OK}$$

Therefore, the deck interior overhang region reinforcement is adequate.

### Resistance of Deck End Overhang Region

The process for checking the end overhang region is the same as for the interior region, except the reinforcement differs. The Memo to Designers (2017-01) directs the designer to use Table 9.2.1.1 for the bottom reinforcement and modify the top reinforcement in regions near an expansion joint. For a 36 inch Type S barrier supported by prestressed beams, use the following reinforcement in accordance with the memo:

Top reinforcement – Hooked #5 bars @ 5" ( $A_{s(\text{top})} = 0.74 \text{ in}^2/\text{ft}$ ) over a distance of 8 feet from the joint.

Bottom reinforcement – #5 bars @ 7" ( $A_{s(\text{bot})} = 0.53 \text{ in}^2/\text{ft}$ )

In the end region, the front leg of the barrier bar also contributes to the strength of the overhang. There is some variation in bar spacing in the end region, but we will conservatively use:

Barrier front leg - #5 bars @ 12" ( $A_{s(\text{bar})} = 0.31 \text{ in}^2/\text{ft}$ )

First, determine the effective area of reinforcement for the deck bars located at the toe of the barrier. From Figure 5.2.2.6 of this manual, the development length,  $\ell_d$ , for the hooked top bars is:

For #5 top bars @ 5" with side cover  $> 2.5"$  and 2" end cover,  $\ell_d = 12"$

$\ell_{d\text{available}} = 16.38" > 12"$ , so top bars are fully developed.

$A_{s(\text{top})\text{eff}} = 0.74 \text{ in}^2/\text{ft}$

The other bars are unchanged, so:

$$A_{s(bot)eff} = 0.23 \text{ in}^2/\text{ft}$$

$$A_{s(bar)eff} = 0.23 \text{ in}^2/\text{ft}$$

Now determine the distance from the bottom of the section to the neutral axis,  $c$ . Start by assuming that for all reinforcement,  $\epsilon_s > \epsilon_y$ . Then:

$$f_s = E_s \cdot \epsilon_y = f_y$$

$$T_{s(top)} = A_{s(top)eff} \cdot f_y = 0.74 \cdot 60 = 44.40 \text{ kips/ft}$$

$$T_{s(bot)} = A_{s(bot)eff} \cdot f_y = 0.23 \cdot 60 = 13.80 \text{ kips/ft}$$

$$T_{s(bar)} = A_{s(bar)eff} \cdot f_y = 0.23 \cdot 60 = 13.80 \text{ kips/ft}$$

$$T_{s(tot)} = 44.40 + 13.80 + 13.80 = 72.00 \text{ kips/ft}$$

The total compression force  $C_c$  is:

$$C_c = 0.85 \cdot f'_c \cdot b \cdot a = 0.85 \cdot 4.0 \cdot 12.0 \cdot 0.85 \cdot c = 34.68 \cdot c$$

Referring to Figure 9.3.7, find  $c$  by taking moments about  $P_n$ :

$$44.40 \cdot (36.48 - 3.11)$$

$$+ 13.80 \cdot (36.48 + 1.27)$$

$$+ 13.80 \cdot (36.48 + 0.27)$$

$$- 34.68 \cdot c \cdot (36.48 + 4.42 - 0.5 \cdot 0.85 \cdot c) = 0$$

$$\text{Solving, we get } c = 1.80 \text{ in}$$

Check if original assumption was correct, that  $\epsilon_s > \epsilon_y$ :

$$\epsilon_y = \frac{f_y}{E_s} = \frac{60}{29,000} = 0.00207$$

$$\epsilon_{s(top)} = (8.84 - 1.31 - 1.80) \cdot \left(\frac{0.003}{1.80}\right) = 0.00955 > 0.00207$$

$$\epsilon_{s(bot)} = (4.42 - 1.27 - 1.80) \cdot \left(\frac{0.003}{1.80}\right) = 0.00225 > 0.00207$$

$$\epsilon_{s(bar)} = (4.42 - 0.27 - 1.80) \cdot \left(\frac{0.003}{1.80}\right) = 0.00392 > 0.00207$$

Therefore the assumption was correct.

Then the compression force  $C_c$  is:

$$C_c = 34.68 \cdot c = 34.68 \cdot 1.80 = 62.42 \text{ kips/ft}$$

And,

$$P_n = T_{s(top)} + T_{s(bot)} + T_{s(bar)} - C_c$$

$$= 44.40 + 13.80 + 13.80 - 62.42 = 9.58 \text{ kips/ft}$$

**[1.3.2.1]**

The resistance factor  $\phi$  for Extreme Event II limit state is 1.0. Therefore,

$$\phi \cdot P_n = 1.0 \cdot 9.58 = 9.58 \text{ kips/ft} > 7.9 \text{ kips/ft} \quad \text{OK}$$

$$\phi \cdot M_n = \phi \cdot P_n \cdot e_u$$

$$= 1.0 \cdot 9.58 \cdot 36.48 \cdot \frac{1}{12} = 29.12 \frac{\text{kip-ft}}{\text{ft}} > 24.0 \frac{\text{kip-ft}}{\text{ft}} \quad \text{OK}$$

Therefore, the end region deck reinforcement is adequate for the end overhang region under Case 1.

**L. Overhang  
Region Analysis,  
Case 2**

Case 2 is Extreme Event II checked at the edge of the beam flange for the dead load plus horizontal collision force plus live load. As noted earlier, live load is not considered due to the overhang geometry. At the edge of the beam flange, the analysis is very similar to that done for Case 1, except the dead load moment will be greater, the cross-section will be deeper, and the  $A_{s(\text{bar})\text{eff}}$  will be substantially less. Because the process is similar, the calculations are not shown and only the important values are included below to confirm the overhang is adequate.

Table 9.3.3 shows the loads for Case 2 and Table 9.3.4 shows results for the overhang resistance to the loads.

**Table 9.3.3 – Determination of Loads for Case 2 Applied to a 1 ft Wide Strip**

|                    | Total<br>WDC<br>(kips) | Total<br>M <sub>DC</sub><br>(kip-ft) | M <sub>cadj</sub><br>(kip-ft) | F <sub>cadj</sub><br>(kips)<br>① | e<br>(ft) | F <sub>cdes</sub><br>(kips) | M <sub>cdes</sub><br>(kip-ft) | M <sub>u</sub><br>(kip-ft) | P <sub>u</sub><br>(kips) | e <sub>u</sub><br>(ft) |
|--------------------|------------------------|--------------------------------------|-------------------------------|----------------------------------|-----------|-----------------------------|-------------------------------|----------------------------|--------------------------|------------------------|
| Interior<br>region | 0.763                  | 0.970                                | 9.4                           | 3.5                              | 2.7       | 3.5                         | 10.8                          | 11.8                       | 3.5                      | 3.37                   |
| End<br>region      | 0.763                  | 0.970                                | 20.5                          | 7.4                              | 2.8       | 7.4                         | 23.6                          | 24.6                       | 7.4                      | 3.32                   |

① Because section for analysis is at the beam flange, the collision load is distributed over:  
 $L_c + 2 \cdot H_{\text{barrier}} + 2 \cdot (\text{distance from edge of beam flange to barrier toe})$  for interior region.  
 $L_c + 1 \cdot H_{\text{barrier}} + 1 \cdot (\text{distance from edge of beam flange to barrier toe})$  for end region.  
 See Figure 9.3.9.

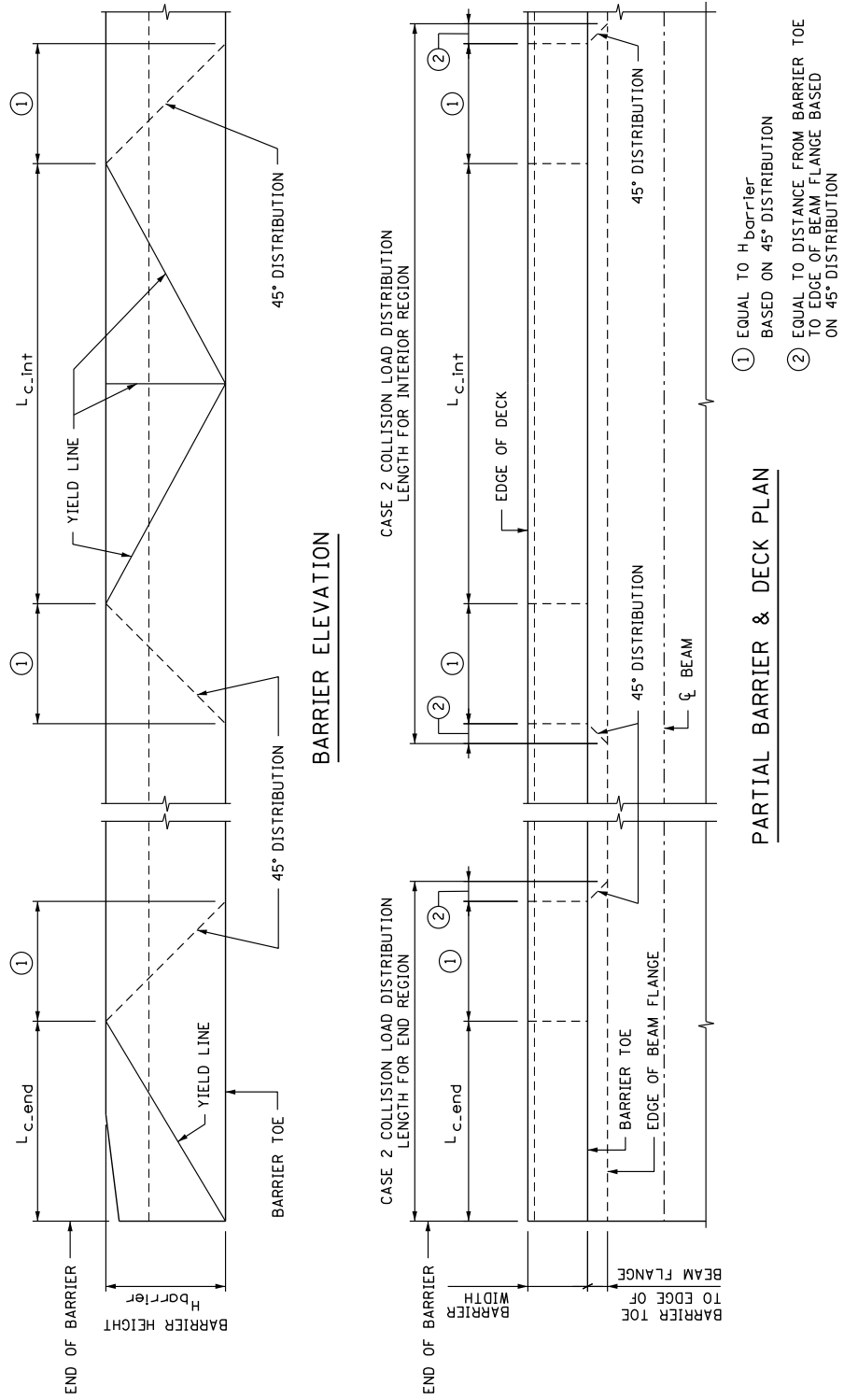

Figure 9.3.9

**Table 9.3.4 – Determination of Deck Overhang Resistance for a 1 ft Wide Strip**

|                 | Overhang Reinforcement      | Effective $A_s$ (in <sup>2</sup> ) | Assumed $T_s$ (kips)<br>① | Arm to $\phi P_n$ (in) | $c$ (in) | Calculated $\epsilon_s > \epsilon_y$ ? | $C_{conc}$ (kips) | $\phi P_n$ (kips) | $\phi M_n$ (kip-ft) |
|-----------------|-----------------------------|------------------------------------|---------------------------|------------------------|----------|--|-------------------|-------------------|---------------------|
| Interior region | Top bars:<br>#4 @ 6"        | 0.40                               | 24.00                     | 36.94                  | 1.34     | 0.01547 > $\epsilon_y$<br>OK           | 46.47             | 6.3               | 21.33               |
|                 | Bottom bars:<br>#5 @ 7"     | 0.34                               | 20.40                     | 41.38                  |          | 0.00553 > $\epsilon_y$<br>OK           |                   |                   |                     |
|                 | Barrier bars:<br>#5 @ 12"   | 0.14                               | 8.40                      | 40.38                  |          | 0.00777 > $\epsilon_y$<br>OK           |                   |                   |                     |
| End region      | Top bars:<br>hooked #5 @ 5" | 0.74                               | 44.40                     | 36.40                  | 1.83     | 0.01043 > $\epsilon_y$<br>OK           | 63.46             | 9.7               | 32.34               |
|                 | Bottom bars:<br>#5 @ 7"     | 0.34                               | 20.40                     | 40.78                  |          | 0.00325 > $\epsilon_y$<br>OK           |                   |                   |                     |
|                 | Barrier bars:<br>#5 @ 12"   | 0.14                               | 8.40                      | 39.78                  |          | 0.00489 > $\epsilon_y$<br>OK           |                   |                   |                     |

① Assumed  $T_s = (\text{Effective } A_s) \cdot f_y$

Based on the table values, the overhang deck reinforcement is adequate for Case 2.

**M. Overhang Region Analysis, Case 4**

The vertical collision load,  $F_v$ , for NCHRP Report 350 Test Level 4 represents the weight of a vehicle lying on top of the barrier and is applied over a length,  $L_v$ :

$$F_v = 18 \text{ kips}$$

$$L_v = 18 \text{ feet.}$$

The moment arm,  $L_{arm}$ , is:

$$L_{arm} = (\text{overhang}) - (\text{coping}) - (\text{barrier width}) - 0.5 \cdot b_f + x_{cg}$$

$$= 42 - 2 - 16.38 - 0.5 \cdot 34 + 10.22$$

$$= 16.84 \text{ in} = 1.40 \text{ ft}$$

Then, conservatively using a distribution length equal to  $L_v$ :

$$M_{v\text{collision}} = \frac{F_v}{L_v} \cdot L_{arm} = \frac{18}{18} \cdot 1.40 = 1.40 \frac{\text{kip-ft}}{\text{ft}}$$

Dead load is the same as calculated previously for Case 2:

$$M_{DC} = 0.970 \text{ kip-ft/ft}$$

Then  $M_u$  for Case 4 is:

$$\begin{aligned}\text{Case 4 } M_u &= M_{\text{vcollision}} + M_{\text{DC}} \\ &= 1.40 + 0.970 \\ &= 2.37 \text{ kip-ft/ft} \ll \text{Case 2 } M_u = 11.8 \text{ kip-ft/ft}\end{aligned}$$

Therefore, by inspection, Case 4 is satisfied.

The deck overhang reinforcement is adequate for all cases.