

MN Dept of Transportation

TRAFFIC DATA COLLECTION - Metro

TH-8 at TH-95, North Jct Taylors Falls
 Ref.Pt.: 022.071
 video JN RE
 TURN MOVEMENT COUNT - WEEKDAY

File Name : TH-8 at TH-95 N jct 2015 Tuesday
 Site Code :
 Start Date : 10/6/2015
 Page No : 1

Groups Printed- Cars + - Trucks																	
Start Time	TH-95 Southbound				TH-8 Westbound				Park Entrance Northbound				TH-8 Eastbound				Int. Total
	Left	Thru	Right	Peds	Left	Thru	Right	Peds	Left	Thru	Right	Peds	Left	Thru	Right	Peds	
06:00	15	0	7	0	0	82	16	0	0	0	0	0	2	13	0	0	135
06:15	18	0	8	0	0	80	28	0	0	0	0	0	1	29	0	0	164
06:30	33	2	9	0	0	71	20	0	0	0	0	0	2	21	1	0	159
06:45	33	0	6	0	0	84	27	0	0	0	0	0	2	31	0	0	183
Total	99	2	30	0	0	317	91	0	0	0	0	0	7	94	1	0	641
07:00	20	0	10	0	0	73	31	0	0	0	0	0	4	35	0	0	173
07:15	33	0	6	0	0	99	26	0	1	0	0	0	4	41	1	0	211
07:30	44	0	8	0	0	81	38	0	0	0	0	0	5	48	1	0	225
07:45	38	0	7	0	1	75	41	0	1	0	0	0	9	53	0	0	225
Total	135	0	31	0	1	328	136	0	2	0	0	0	22	177	2	0	834
08:00	34	1	8	0	0	49	22	0	0	0	0	0	8	44	0	0	166
08:15	29	1	3	0	1	54	31	0	0	0	0	0	7	28	1	0	155
08:30	37	0	7	0	1	51	26	0	2	0	0	0	6	45	3	0	178
08:45	43	0	12	0	1	59	44	0	0	3	0	0	3	54	4	0	223
Total	143	2	30	0	3	213	123	0	2	3	0	0	24	171	8	0	722
***** BREAK *****																	
11:00	49	1	6	0	5	65	53	0	1	1	3	0	10	58	3	0	255
11:15	44	2	7	0	2	58	45	0	2	1	2	0	8	46	4	0	221
11:30	41	3	10	0	1	53	49	0	5	2	1	0	8	58	6	0	237
11:45	40	4	7	0	0	61	39	0	3	3	3	0	11	49	2	2	224
Total	174	10	30	0	8	237	186	0	11	7	9	0	37	211	15	2	937
12:00	46	1	8	0	1	47	36	0	0	2	1	0	11	48	6	0	207
12:15	37	2	10	0	3	55	50	0	1	3	3	0	12	47	3	0	226
12:30	42	1	9	0	4	70	52	0	2	7	1	0	9	43	6	0	246
12:45	53	2	11	0	1	58	48	0	4	2	2	0	11	51	9	2	254
Total	178	6	38	0	9	230	186	0	7	14	7	0	43	189	24	2	933
13:00	0	0	0	0	0	0	0	0	0	0	0	0	0	2	0	0	2
***** BREAK *****																	
Total	0	0	0	0	0	0	0	0	0	0	0	0	0	2	0	0	2
***** BREAK *****																	
15:00	54	1	12	0	1	68	46	0	10	2	5	0	11	88	3	2	303
15:15	61	0	13	0	1	72	47	0	7	5	1	0	16	85	2	0	310
15:30	67	0	20	0	1	63	75	0	4	2	1	0	12	105	3	0	353
15:45	59	1	12	0	0	66	61	0	3	1	2	0	14	87	0	0	306
Total	241	2	57	0	3	269	229	0	24	10	9	0	53	365	8	2	1272
16:00	41	1	8	0	1	68	63	0	2	5	0	0	7	121	2	0	319
16:15	55	1	4	0	0	70	62	0	1	0	0	0	18	130	1	0	342
16:30	65	0	16	0	0	76	69	0	0	1	0	0	12	120	1	2	362
16:45	65	0	13	0	2	76	66	0	3	1	0	0	12	102	2	0	342
Total	226	2	41	0	3	290	260	0	6	7	0	0	49	473	6	2	1365
17:00	50	4	18	0	0	72	75	0	2	0	1	0	23	118	3	0	366
17:15	54	0	9	0	0	62	61	0	3	2	1	0	11	94	2	0	299
17:30	36	2	7	0	0	84	55	0	1	0	1	0	9	93	2	0	290
17:45	44	7	8	0	3	81	58	0	0	0	0	0	10	77	6	0	294
Total	184	13	42	0	3	299	249	0	6	2	3	0	53	382	13	0	1249
Grand Total	1380	37	299	0	30	2183	1460	0	58	43	28	0	288	2064	77	8	7955
Apprch %	80.4	2.2	17.4	0	0.8	59.4	39.7	0	45	33.3	21.7	0	11.8	84.7	3.2	0.3	
Total %	17.3	0.5	3.8	0	0.4	27.4	18.4	0	0.7	0.5	0.4	0	3.6	25.9	1	0.1	
Cars +	1338	36	296	0	30	2064	1403	0	58	43	27	0	285	1950	77	8	7615
% Cars +	97	97.3	99	0	100	94.5	96.1	0	100	100	96.4	0	99	94.5	100	100	95.7

MN Dept of Transportation

TRAFFIC DATA COLLECTION - Metro

TH-8 at TH-95, North Jct Taylors Falls
 Ref.Pt.: 022.071
 video JN RE
 TURN MOVEMENT COUNT - WEEKDAY

File Name : TH-8 at TH-95 N jct 2015 Tuesday
 Site Code :
 Start Date : 10/6/2015
 Page No : 2

Groups Printed- Cars + - Trucks

	TH-95 Southbound				TH-8 Westbound				Park Entrance Northbound				TH-8 Eastbound				Int. Total
	Left	Thru	Right	Peds	Left	Thru	Right	Peds	Left	Thru	Right	Peds	Left	Thru	Right	Peds	
Trucks	42	1	3	0	0	119	57	0	0	0	1	0	3	114	0	0	340
% Trucks	3	2.7	1	0	0	5.5	3.9	0	0	0	3.6	0	1	5.5	0	0	4.3

MN Dept of Transportation

TRAFFIC DATA COLLECTION - Metro

TH-8 at TH-95, North Jct Taylors Falls
 Ref.Pt.: 022.071
 video JN RE
 TURN MOVEMENT COUNT - WEEKDAY

File Name : TH-8 at TH-95 N jct 2015 Tuesday
 Site Code :
 Start Date : 10/6/2015
 Page No : 3

Start Time	TH-95 Southbound					TH-8 Westbound					Park Entrance Northbound					TH-8 Eastbound					Int. Total
	Left	Thru	Right	Peds	App. Total	Left	Thru	Right	Peds	App. Total	Left	Thru	Right	Peds	App. Total	Left	Thru	Right	Peds	App. Total	
Peak Hour Analysis From 06:00 to 08:45 - Peak 1 of 1																					
Peak Hour for Entire Intersection Begins at 07:00																					
07:00	20	0	10	0	30	0	73	31	0	104	0	0	0	0	0	4	35	0	0	39	173
07:15	33	0	6	0	39	0	99	26	0	125	1	0	0	0	1	4	41	1	0	46	211
07:30	44	0	8	0	52	0	81	38	0	119	0	0	0	0	0	5	48	1	0	54	225
07:45	38	0	7	0	45	1	75	41	0	117	1	0	0	0	1	9	53	0	0	62	225
Total Volume	135	0	31	0	166	1	328	136	0	465	2	0	0	0	2	22	177	2	0	201	834
% App. Total	81.3	0	18.7	0		0.2	70.5	29.2	0		100	0	0	0		10.9	88.1	1	0		
PHF	.767	.000	.775	.000	.798	.250	.828	.829	.000	.930	.500	.000	.000	.000	.500	.611	.835	.500	.000	.810	.927

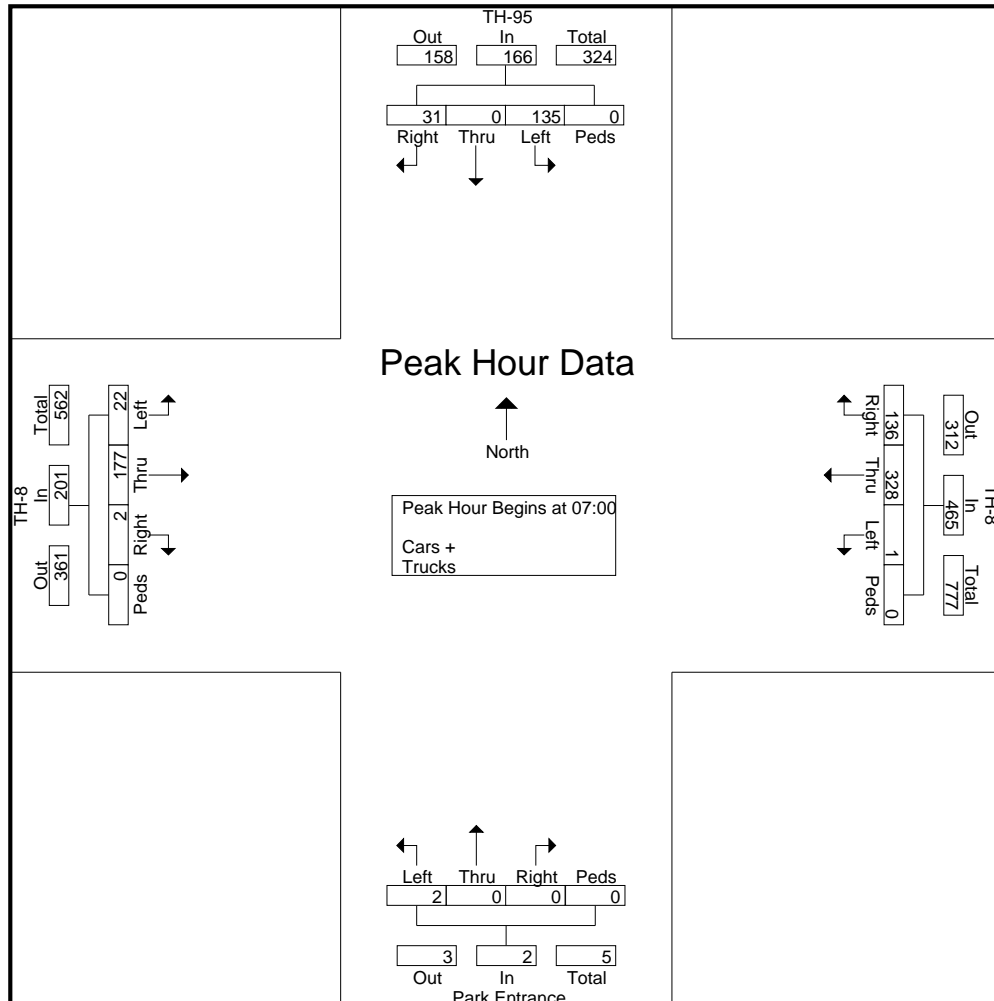

MN Dept of Transportation

TRAFFIC DATA COLLECTION - Metro

TH-8 at TH-95, North Jct Taylors Falls
 Ref.Pt.: 022.071
 video JN RE
 TURN MOVEMENT COUNT - WEEKDAY

File Name : TH-8 at TH-95 N jct 2015 Tuesday
 Site Code :
 Start Date : 10/6/2015
 Page No : 4

Start Time	TH-95 Southbound					TH-8 Westbound					Park Entrance Northbound					TH-8 Eastbound					Int. Total
	Left	Thru	Right	Peds	App. Total	Left	Thru	Right	Peds	App. Total	Left	Thru	Right	Peds	App. Total	Left	Thru	Right	Peds	App. Total	
Peak Hour Analysis From 15:00 to 17:45 - Peak 1 of 1																					
Peak Hour for Entire Intersection Begins at 16:15																					
16:15	55	1	4	0	60	0	70	62	0	132	1	0	0	0	1	18	130	1	0	149	342
16:30	65	0	16	0	81	0	76	69	0	145	0	1	0	0	1	12	120	1	2	135	362
16:45	65	0	13	0	78	2	76	66	0	144	3	1	0	0	4	12	102	2	0	116	342
17:00	50	4	18	0	72	0	72	75	0	147	2	0	1	0	3	23	118	3	0	144	366
Total Volume	235	5	51	0	291	2	294	272	0	568	6	2	1	0	9	65	470	7	2	544	1412
% App. Total	80.8	1.7	17.5	0		0.4	51.8	47.9	0		66.7	22.2	11.1	0		11.9	86.4	1.3	0.4		
PHF	.904	.313	.708	.000	.898	.250	.967	.907	.000	.966	.500	.500	.250	.000	.563	.707	.904	.583	.250	.913	.964

