



# MINNESOTA DEPT OF TRANSPORTATION

TRAFFIC DATA COLLECTION - METRO

TH-8 AT PLEASANT VALLEY RD/CSAH-26&82 File Name : TH-8 AT PLEASANT VALLEY RD 2006

REF.PT.: 014.327

Site Code : 00000000

JAMAR # 631 RE

Start Date : 8/30/2006

TURN MOVEMENT COUNT

Page No : 1

Groups Printed- Cars & Trucks

Start Time	PLEASANT VALLEY RD /CSAH-82 Southbound				TH-8 Westbound				PLEASANT VALLEY RD /CSAH-26 Northbound				TH-8 Eastbound				Int. Total
	Left	Thru	Right	Peds	Left	Thru	Right	Peds	Left	Thru	Right	Peds	Left	Thru	Right	Peds	
06:00	0	6	0	0	3	73	0	0	6	2	0	0	0	18	14	0	122
06:15	0	4	0	0	5	109	1	0	8	0	1	0	0	29	23	0	180
06:30	0	10	0	0	6	101	0	0	8	0	2	0	0	31	25	0	183
06:45	0	6	0	0	11	105	1	0	11	0	0	0	0	25	24	0	183
Total	0	26	0	0	25	388	2	0	33	2	3	0	0	103	86	0	668
07:00	1	3	0	0	2	85	0	0	10	1	0	0	0	44	26	0	172
07:15	0	6	0	0	7	84	0	0	18	2	0	0	0	41	33	0	191
07:30	1	5	0	0	12	85	1	0	8	0	1	0	0	36	27	0	176
07:45	0	5	1	0	36	108	0	0	15	1	0	0	1	59	54	0	280
Total	2	19	1	0	57	362	1	0	51	4	1	0	1	180	140	0	819
08:00	0	5	0	0	11	82	0	0	11	1	3	0	0	42	37	0	192
08:15	0	1	0	0	5	89	0	0	16	0	2	0	1	37	26	0	177
08:30	0	4	0	0	0	74	1	0	16	0	1	0	0	37	26	0	159
08:45	0	3	0	0	1	80	0	0	12	0	0	0	0	50	21	0	167
Total	0	13	0	0	17	325	1	0	55	1	6	0	1	166	110	0	695
*** BREAK ***																	
15:00	0	2	0	0	2	84	0	0	21	6	6	0	0	115	14	0	250
15:15	0	0	1	0	1	65	1	0	21	7	9	0	0	100	22	0	227
15:30	0	2	0	0	0	55	1	0	23	4	13	0	2	84	11	0	195
15:45	0	0	0	0	5	55	1	0	17	0	6	0	0	89	9	0	182
Total	0	4	1	0	8	259	3	0	82	17	34	0	2	388	56	0	854
16:00	1	0	0	0	2	88	1	0	24	6	5	0	1	110	13	0	251
16:15	0	0	0	0	3	76	0	0	28	5	7	0	1	111	14	0	245
16:30	0	1	1	0	2	68	0	0	65	12	21	0	3	131	12	0	316
16:45	0	1	0	0	6	73	0	0	39	6	12	0	2	123	17	0	279
Total	1	2	1	0	13	305	1	0	156	29	45	0	7	475	56	0	1091
17:00	0	3	1	0	0	69	2	0	41	4	4	0	1	121	21	0	267
17:15	0	1	0	0	0	69	0	0	22	3	5	0	0	106	14	0	220
17:30	1	2	0	0	0	66	3	0	20	7	5	0	0	129	8	0	241
17:45	0	1	0	0	2	54	0	0	24	3	7	0	0	108	15	0	214
Total	1	7	1	0	2	258	5	0	107	17	21	0	1	464	58	0	942
Grand Total	4	71	4	0	122	1897	13	0	484	70	110	0	12	1776	506	0	5069
Apprch %	5.1	89.9	5.1	0	6	93.4	0.6	0	72.9	10.5	16.6	0	0.5	77.4	22.1	0	
Total %	0.1	1.4	0.1	0	2.4	37.4	0.3	0	9.5	1.4	2.2	0	0.2	35	10	0	



# MINNESOTA DEPT OF TRANSPORTATION

## TRAFFIC DATA COLLECTION - METRO

TH-8 AT PLEASANT VALLEY RD/CSAH-26&82 File Name : TH-8 AT PLEASANT VALLEY RD 2006  
 REF.PT.: 014.327 Site Code : 00000000  
 JAMAR # 631 RE Start Date : 8/30/2006  
 TURN MOVEMENT COUNT Page No : 2

Start Time	PLEASANT VALLEY RD /CSAH-82 Southbound					TH-8 Westbound					PLEASANT VALLEY RD /CSAH-26 Northbound					TH-8 Eastbound					Int. Total
	Left	Thru	Right	Peds	App. Total	Left	Thru	Right	Peds	App. Total	Left	Thru	Right	Peds	App. Total	Left	Thru	Right	Peds	App. Total	
Peak Hour Analysis From 06:00 to 08:45 - Peak 1 of 1																					
Peak Hour for Entire Intersection Begins at 07:15																					
07:15	0	6	0	0	6	7	84	0	0	91	18	2	0	0	20	0	41	33	0	74	191
07:30	1	5	0	0	6	12	85	1	0	98	8	0	1	0	9	0	36	27	0	63	176
07:45	0	5	1	0	6	36	108	0	0	144	15	1	0	0	16	1	59	54	0	114	280
08:00	0	5	0	0	5	11	82	0	0	93	11	1	3	0	15	0	42	37	0	79	192
Total Volume	1	21	1	0	23	66	359	1	0	426	52	4	4	0	60	1	178	151	0	330	839
% App. Total	4.3	91.3	4.3	0		15.5	84.3	0.2	0		86.7	6.7	6.7	0		0.3	53.9	45.8	0		
PHF	.250	.875	.250	.000	.958	.458	.831	.250	.000	.740	.722	.500	.333	.000	.750	.250	.754	.699	.000	.724	.749

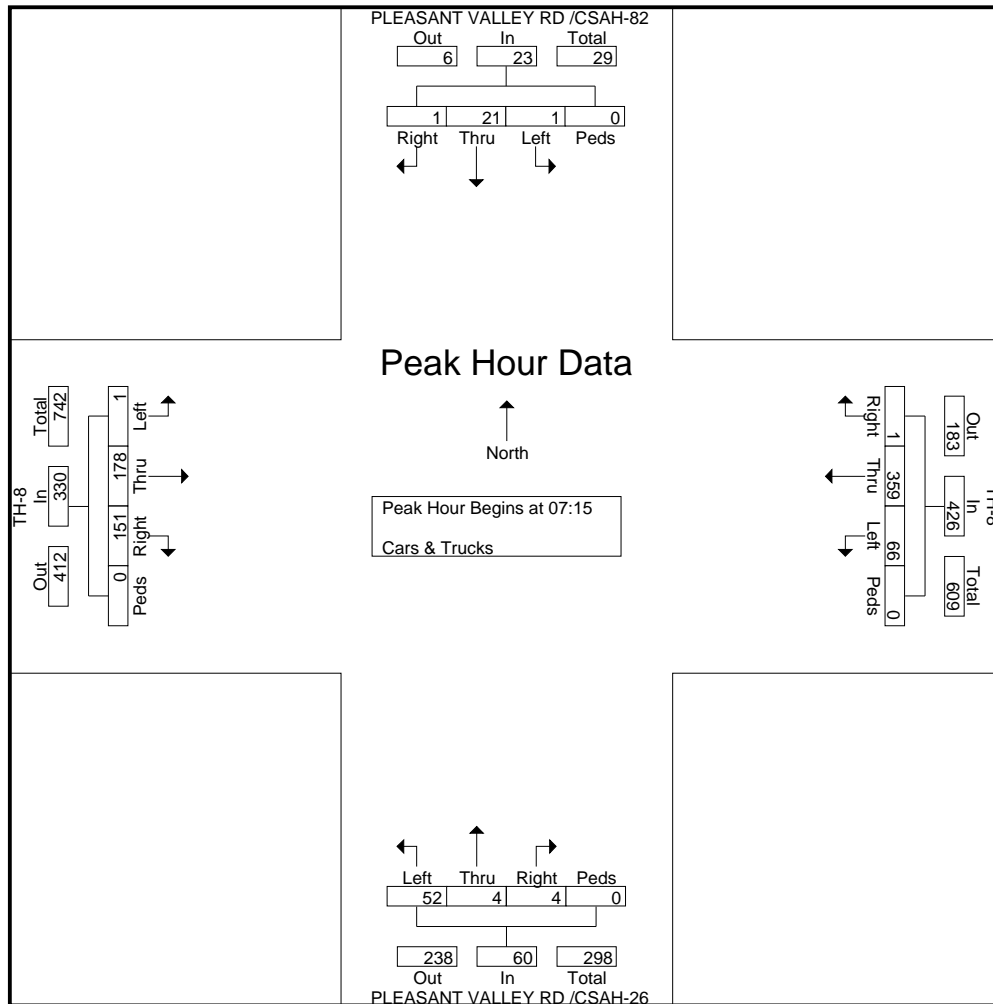



# MINNESOTA DEPT OF TRANSPORTATION

## TRAFFIC DATA COLLECTION - METRO

TH-8 AT PLEASANT VALLEY RD/CSAH-26&82 File Name : TH-8 AT PLEASANT VALLEY RD 2006  
 REF.PT.: 014.327 Site Code : 00000000  
 JAMAR # 631 RE Start Date : 8/30/2006  
 TURN MOVEMENT COUNT Page No : 3

Start Time	PLEASANT VALLEY RD /CSAH-82 Southbound					TH-8 Westbound					PLEASANT VALLEY RD /CSAH-26 Northbound					TH-8 Eastbound					Int. Total
	Left	Thru	Right	Peds	App. Total	Left	Thru	Right	Peds	App. Total	Left	Thru	Right	Peds	App. Total	Left	Thru	Right	Peds	App. Total	
Peak Hour Analysis From 15:00 to 17:45 - Peak 1 of 1																					
Peak Hour for Entire Intersection Begins at 16:15																					
16:15	0	0	0	0	0	3	76	0	0	79	28	5	7	0	40	1	111	14	0	126	245
16:30	0	1	1	0	2	2	68	0	0	70	65	12	21	0	98	3	131	12	0	146	316
16:45	0	1	0	0	1	6	73	0	0	79	39	6	12	0	57	2	123	17	0	142	279
17:00	0	3	1	0	4	0	69	2	0	71	41	4	4	0	49	1	121	21	0	143	267
Total Volume	0	5	2	0	7	11	286	2	0	299	173	27	44	0	244	7	486	64	0	557	1107
% App. Total	0	71.4	28.6	0		3.7	95.7	0.7	0		70.9	11.1	18	0		1.3	87.3	11.5	0		
PHF	.000	.417	.500	.000	.438	.458	.941	.250	.000	.946	.665	.563	.524	.000	.622	.583	.927	.762	.000	.954	.876

