

TRAFFIC DATA INC.

3268 Xenwood Ave S
St Louis Park, MN 55416

TH-8 at Co.Rd.36/ E Viking Blvd/Co.Rd.22
Ref.Pt.: 007.373
TDI Inc
TURN MOVEMENT COUNT

File Name : 26811110 Hwy 8 & CR 22
Site Code : 26811110
Start Date : 2/23/2011
Page No : 1

Groups Printed- Class 1

Start Time	TH-8 / Lake Blvd Southbound				Johnson Lane Westbound				TH-8 / Lake Blvd Northbound				Co.Rd.36 / E Viking Blvd Eastbound				Int. Total
	Left	Thru	Rght	Peds	Left	Thru	Rght	Peds	Left	Thru	Rght	Peds	Left	Thru	Rght	Peds	
06:00	0	193	9	0	4	0	0	0	0	22	0	0	3	0	7	0	238
06:15	0	170	12	0	0	0	0	0	1	34	0	0	8	0	10	0	235
06:30	0	145	23	0	3	0	1	0	1	42	0	0	14	0	5	0	234
06:45	0	162	27	0	2	1	1	0	2	39	0	0	20	0	9	0	263
Total	0	670	71	0	9	1	2	0	4	137	0	0	45	0	31	0	970
07:00	0	159	39	0	0	0	4	0	0	55	1	0	43	0	9	0	310
07:15	1	172	34	0	3	0	0	0	1	59	0	0	23	0	7	0	300
07:30	2	160	53	0	3	1	2	0	4	89	0	0	25	0	6	0	345
07:45	0	122	54	0	1	0	0	0	2	104	0	0	19	0	2	0	304
Total	3	613	180	0	7	1	6	0	7	307	1	0	110	0	24	0	1259
08:00	0	91	50	0	0	0	0	0	8	67	0	0	37	0	8	0	261
08:15	0	106	25	0	0	0	0	0	1	55	0	0	33	0	8	0	228
08:30	0	109	23	0	1	0	1	0	3	71	0	0	24	0	4	0	236
08:45	1	111	29	0	0	0	2	0	2	58	0	0	20	0	4	0	227
Total	1	417	127	0	1	0	3	0	14	251	0	0	114	0	24	0	952
09:00	0	102	12	0	1	1	0	0	1	62	0	0	25	0	2	0	206
09:15	2	102	24	0	0	0	1	0	0	51	0	0	9	1	7	0	197
09:30	0	107	20	0	1	0	1	0	1	62	0	0	15	0	3	0	210
09:45	1	101	15	0	2	0	0	0	1	64	0	0	24	0	7	0	215
Total	3	412	71	0	4	1	2	0	3	239	0	0	73	1	19	0	828
10:00	0	81	20	0	0	1	0	0	0	66	1	0	19	1	1	0	190
10:15	0	79	14	0	0	1	1	0	3	65	0	0	19	1	1	0	184
10:30	0	91	20	0	0	0	0	0	2	62	0	0	18	0	4	0	197
10:45	1	91	22	0	0	0	0	0	2	78	0	0	26	0	1	0	221
Total	1	342	76	0	0	2	1	0	7	271	1	0	82	2	7	0	792
11:00	0	76	20	0	1	0	0	0	1	80	0	0	21	0	2	0	201
11:15	1	86	22	0	0	0	0	0	5	72	0	0	26	0	3	0	215
11:30	0	81	25	0	0	0	2	0	0	55	1	0	21	0	3	0	188
11:45	1	111	21	0	0	0	0	0	1	74	1	0	24	0	3	0	236
Total	2	354	88	0	1	0	2	0	7	281	2	0	92	0	11	0	840
12:00	1	82	21	0	1	0	0	0	5	77	4	0	21	0	6	0	218
12:15	1	97	12	0	1	0	1	0	4	65	0	0	21	0	7	0	209
12:30	0	89	26	0	4	0	1	0	1	73	1	0	14	0	4	0	213
12:45	0	87	16	0	1	0	0	0	5	81	1	0	18	0	2	0	211
Total	2	355	75	0	7	0	2	0	15	296	6	0	74	0	19	0	851
13:00	2	66	16	0	0	0	0	0	3	94	1	0	8	0	1	0	191
13:15	2	94	21	0	0	0	1	0	4	82	2	0	22	0	7	0	235
13:30	0	89	13	0	0	0	1	0	2	74	0	0	17	0	2	0	198
13:45	0	80	21	0	0	1	0	0	4	97	1	0	24	0	1	0	229
Total	4	329	71	0	0	1	2	0	13	347	4	0	71	0	11	0	853
14:00	0	80	19	0	0	0	1	0	5	95	0	0	20	1	7	0	228
14:15	1	63	15	0	0	0	1	0	4	90	2	0	16	0	5	0	197
14:30	0	83	20	1	2	0	1	0	6	107	1	0	18	0	1	0	240
14:45	0	90	29	0	0	0	1	0	8	107	1	0	25	0	8	0	269
Total	1	316	83	1	2	0	4	0	23	399	4	0	79	1	21	0	934
15:00	0	70	23	0	0	0	0	0	6	115	1	0	35	0	7	0	257
15:15	0	89	23	1	0	0	1	0	6	128	0	0	35	0	2	0	285
15:30	1	93	30	0	0	0	0	0	7	154	0	0	42	0	6	0	333

TRAFFIC DATA INC.

3268 Xenwood Ave S
St Louis Park, MN 55416

TH-8 at Co.Rd.36/ E Viking Blvd/Co.Rd.22

Ref.Pt.: 007.373

TDI Inc

TURN MOVEMENT COUNT

File Name : 26811110 Hwy 8 & CR 22

Site Code : 26811110

Start Date : 2/23/2011

Page No : 2

Groups Printed- Class 1

Start Time	TH-8 / Lake Blvd Southbound				Johnson Lane Westbound				TH-8 / Lake Blvd Northbound				Co.Rd.36 / E Viking Blvd Eastbound				Int. Total
	Left	Thru	Rght	Peds	Left	Thru	Rght	Peds	Left	Thru	Rght	Peds	Left	Thru	Rght	Peds	
15:45	1	87	34	0	1	0	1	0	7	172	1	0	37	0	2	0	343
Total	2	339	110	1	1	0	2	0	26	569	2	0	149	0	17	0	1218
16:00	0	78	33	0	1	1	0	0	11	167	0	0	47	0	2	0	340
16:15	1	98	32	0	1	0	0	0	9	192	0	0	43	0	7	0	383
16:30	0	107	32	0	1	0	1	0	9	201	0	0	57	1	6	0	415
16:45	1	114	28	0	0	0	2	0	6	190	2	0	53	0	2	0	398
Total	2	397	125	0	3	1	3	0	35	750	2	0	200	1	17	0	1536
17:00	2	110	28	0	2	1	0	0	11	208	2	0	60	0	1	0	425
17:15	2	85	28	0	2	0	4	0	7	171	3	0	38	0	8	0	348
17:30	1	74	35	0	0	1	0	0	12	173	2	0	32	0	1	0	331
17:45	4	72	28	0	0	0	0	0	6	189	1	0	33	0	2	0	335
Total	9	341	119	0	4	2	4	0	36	741	8	0	163	0	12	0	1439
18:00	1	63	29	0	0	0	2	0	7	142	3	0	30	1	6	0	284
18:15	3	62	33	0	0	1	1	0	5	139	1	0	30	0	2	0	277
18:30	1	53	16	0	0	0	2	0	5	140	1	0	20	0	4	0	242
18:45	0	48	31	0	0	0	3	0	13	115	3	0	21	0	6	0	240
Total	5	226	109	0	0	1	8	0	30	536	8	0	101	1	18	0	1043
Grand Total	35	5111	1305	2	39	10	41	0	220	5124	38	0	1353	6	231	0	13515
Apprch %	0.5	79.2	20.2	0	43.3	11.1	45.6	0	4.1	95.2	0.7	0	85.1	0.4	14.5	0	
Total %	0.3	37.8	9.7	0	0.3	0.1	0.3	0	1.6	37.9	0.3	0	10	0	1.7	0	

TRAFFIC DATA INC.

3268 Xenwood Ave S
St Louis Park, MN 55416

TH-8 at Co.Rd.36/ E Viking Blvd/Co.Rd.22
Ref.Pt.: 007.373
TDI Inc
TURN MOVEMENT COUNT

File Name : 26811110 Hwy 8 & CR 22
Site Code : 26811110
Start Date : 2/23/2011
Page No : 3

Start Time	TH-8 / Lake Blvd Southbound					Johnson Lane Westbound					TH-8 / Lake Blvd Northbound					Co.Rd.36 / E Viking Blvd Eastbound					Int. Total
	Left	Thru	Right	Peds	App. Total	Left	Thru	Right	Peds	App. Total	Left	Thru	Right	Peds	App. Total	Left	Thru	Right	Peds	App. Total	
Peak Hour Analysis From 06:00 to 09:30 - Peak 1 of 1																					
Peak Hour for Entire Intersection Begins at 07:00																					
07:00	0	159	39	0	198	0	0	4	0	4	0	55	1	0	56	43	0	9	0	52	310
07:15	1	172	34	0	207	3	0	0	0	3	1	59	0	0	60	23	0	7	0	30	300
07:30	2	160	53	0	215	3	1	2	0	6	4	89	0	0	93	25	0	6	0	31	345
07:45	0	122	54	0	176	1	0	0	0	1	2	104	0	0	106	19	0	2	0	21	304
Total Volume	3	613	180	0	796	7	1	6	0	14	7	307	1	0	315	110	0	24	0	134	1259
% App. Total	0.4	77	22.6	0		50	7.1	42.9	0		2.2	97.5	0.3	0		82.1	0	17.9	0		
PHF	.375	.891	.833	.000	.926	.583	.250	.375	.000	.583	.438	.738	.250	.000	.743	.640	.000	.667	.000	.644	.912

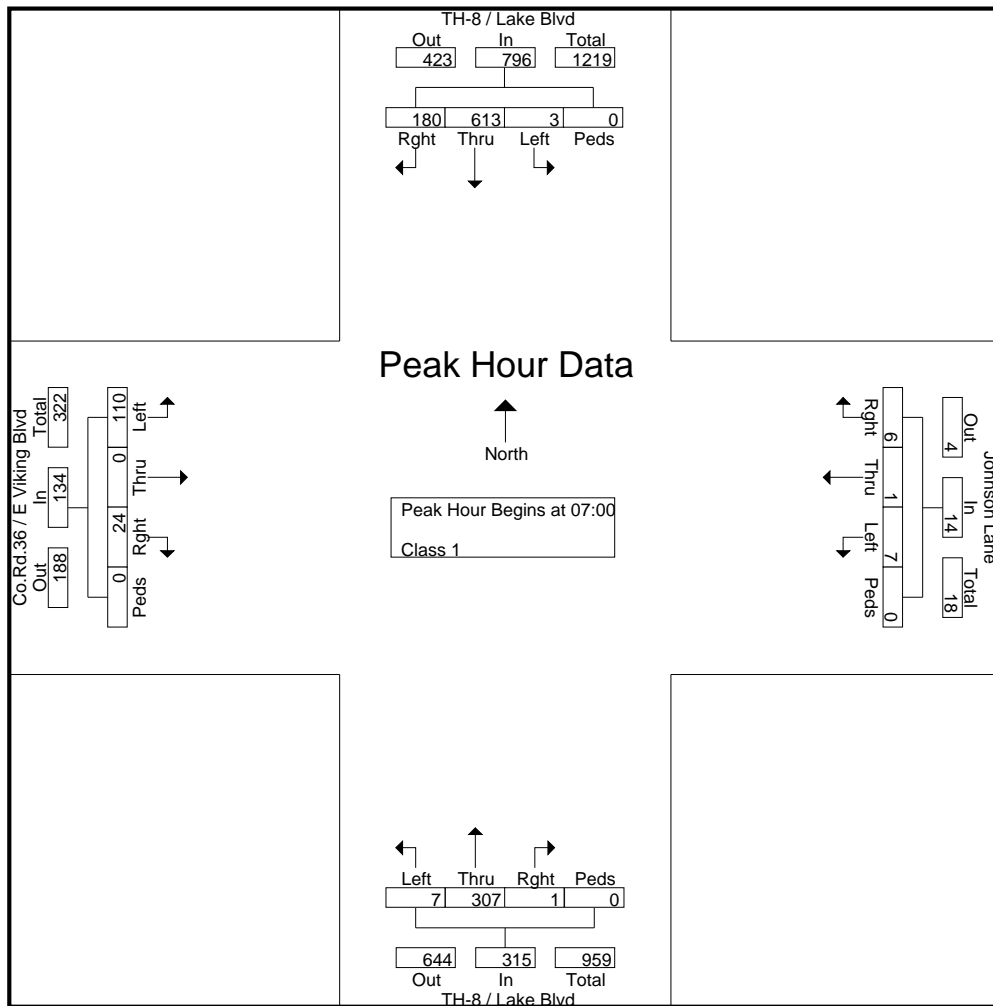

TRAFFIC DATA INC.

3268 Xenwood Ave S
St Louis Park, MN 55416

TH-8 at Co.Rd.36/ E Viking Blvd/Co.Rd.22
Ref.Pt.: 007.373
TDI Inc
TURN MOVEMENT COUNT

File Name : 26811110 Hwy 8 & CR 22
Site Code : 26811110
Start Date : 2/23/2011
Page No : 4

Start Time	TH-8 / Lake Blvd Southbound					Johnson Lane Westbound					TH-8 / Lake Blvd Northbound					Co.Rd.36 / E Viking Blvd Eastbound					Int. Total
	Left	Thru	Rght	Peds	App. Total	Left	Thru	Rght	Peds	App. Total	Left	Thru	Rght	Peds	App. Total	Left	Thru	Rght	Peds	App. Total	
Peak Hour Analysis From 14:30 to 18:45 - Peak 1 of 1																					
Peak Hour for Entire Intersection Begins at 16:15																					
16:15	1	98	32	0	131	1	0	0	0	1	9	192	0	0	201	43	0	7	0	50	383
16:30	0	107	32	0	139	1	0	1	0	2	9	201	0	0	210	57	1	6	0	64	415
16:45	1	114	28	0	143	0	0	2	0	2	6	190	2	0	198	53	0	2	0	55	398
17:00	2	110	28	0	140	2	1	0	0	3	11	208	2	0	221	60	0	1	0	61	425
Total Volume	4	429	120	0	553	4	1	3	0	8	35	791	4	0	830	213	1	16	0	230	1621
% App. Total	0.7	77.6	21.7	0		50	12.5	37.5	0		4.2	95.3	0.5	0		92.6	0.4	7	0		
PHF	.500	.941	.938	.000	.967	.500	.250	.375	.000	.667	.795	.951	.500	.000	.939	.888	.250	.571	.000	.898	.954

