



# MINNESOTA DEPT OF TRANSPORTATION

## TRAFFIC DATA COLLECTION - METRO

TH-7 at TH-100, East Ramps

ref.pt.: 194.248

collected by: ALLIANT CONSULT.

TURN MOVEMENT COUNT

File Name : TH-7 at TH-100 East Ramps 2007

Site Code : 00000168

Start Date : 12/12/2007

Page No : 1

### Groups Printed- Cars & Trucks

Start Time	ramp to NB TH-100 Southbound				CSAH-25 Westbound				ramp from NB TH-100 Northbound				TH-7 Eastbound				Int. Total
	Left	Thru	Right	Peds	Left	Thru	Right	Peds	Left	Thru	Right	Peds	Left	Thru	Right	Peds	
06:00	0	0	0	0	0	20	13	0	9	0	8	0	32	57	0	0	139
06:15	0	0	0	0	0	45	22	0	15	0	17	0	53	83	0	0	235
06:30	0	0	0	0	0	70	28	0	17	0	21	0	61	132	0	0	329
06:45	0	0	0	0	0	87	48	0	10	0	31	0	67	109	0	0	352
Total	0	0	0	0	0	222	111	0	51	0	77	0	213	381	0	0	1055
07:00	0	0	0	0	0	94	54	0	21	0	24	0	82	147	0	0	422
07:15	0	0	0	0	0	117	52	0	25	0	37	0	106	221	0	0	558
07:30	0	0	0	0	0	198	59	0	25	0	32	0	147	243	0	0	704
07:45	0	0	0	0	0	170	70	0	27	0	22	0	150	300	0	0	739
Total	0	0	0	0	0	579	235	0	98	0	115	0	485	911	0	0	2423
08:00	0	0	0	0	0	156	48	0	17	0	22	0	157	204	0	0	604
08:15	0	0	0	0	0	160	49	0	18	0	25	0	162	220	0	0	634
08:30	0	0	0	0	0	158	54	0	33	1	43	0	107	215	0	0	611
08:45	0	0	0	0	0	141	42	0	30	0	50	0	139	178	0	0	580
Total	0	0	0	0	0	615	193	0	98	1	140	0	565	817	0	0	2429
09:00	0	0	0	0	0	121	53	0	31	0	34	0	109	141	0	0	489
09:15	0	0	0	0	0	97	56	0	36	0	43	0	96	127	0	0	455
*** BREAK ***																	
Total	0	0	0	0	0	218	109	0	67	0	77	0	205	268	0	0	944
*** BREAK ***																	
10:30	0	0	0	0	0	92	33	0	37	0	23	0	51	108	0	0	344
10:45	0	0	0	0	0	112	42	0	36	0	33	0	55	130	0	0	408
Total	0	0	0	0	0	204	75	0	73	0	56	0	106	238	0	0	752
11:00	0	0	0	0	0	108	37	0	32	0	28	0	58	148	0	0	411
11:15	0	0	0	0	0	103	41	0	45	0	36	0	54	141	0	0	420
11:30	0	0	0	0	0	133	45	0	54	0	25	0	61	137	0	0	455
11:45	0	0	0	0	0	101	47	0	51	1	34	0	72	165	0	0	471
Total	0	0	0	0	0	445	170	0	182	1	123	0	245	591	0	0	1757
12:00	0	0	0	0	0	103	40	0	39	0	40	0	61	168	0	0	451
12:15	0	0	0	0	0	119	35	0	49	0	23	0	77	157	0	0	460
12:30	0	0	0	0	0	91	48	0	51	0	31	0	77	137	0	0	435
12:45	0	0	0	0	0	124	42	0	40	0	37	0	90	159	0	0	492
Total	0	0	0	0	0	437	165	0	179	0	131	0	305	621	0	0	1838
13:00	0	0	0	0	0	127	46	0	61	0	28	0	52	160	0	0	474
13:15	0	0	0	0	0	134	47	0	41	0	29	0	58	110	0	0	419
*** BREAK ***																	
Total	0	0	0	0	0	261	93	0	102	0	57	0	110	270	0	0	893
*** BREAK ***																	
14:30	0	0	0	0	0	154	56	0	52	1	35	0	85	177	0	0	560
14:45	0	0	0	0	0	120	60	0	58	0	31	0	103	125	0	0	497
Total	0	0	0	0	0	274	116	0	110	1	66	0	188	302	0	0	1057
15:00	0	0	0	0	0	128	71	0	44	0	40	0	133	164	0	0	580
15:15	0	0	0	0	0	159	67	0	44	0	47	0	142	157	0	0	616
15:30	0	0	0	0	0	122	78	0	51	0	55	0	141	164	0	0	611
15:45	0	0	0	0	0	169	54	0	45	0	27	0	169	192	0	0	656
Total	0	0	0	0	0	578	270	0	184	0	169	0	585	677	0	0	2463



# MINNESOTA DEPT OF TRANSPORTATION

## TRAFFIC DATA COLLECTION - METRO

TH-7 at TH-100, East Ramps

ref.pt.: 194.248

collected by: ALLIANT CONSULT.

TURN MOVEMENT COUNT

File Name : TH-7 at TH-100 East Ramps 2007

Site Code : 00000168

Start Date : 12/12/2007

Page No : 2

Groups Printed- Cars & Trucks

Start Time	ramp to NB TH-100 Southbound				CSAH-25 Westbound				ramp from NB TH-100 Northbound				TH-7 Eastbound				Int. Total
	Left	Thru	Right	Peds	Left	Thru	Right	Peds	Left	Thru	Right	Peds	Left	Thru	Right	Peds	
16:00	0	0	0	0	0	187	60	0	62	0	52	0	193	199	0	0	753
16:15	0	0	0	0	0	158	61	0	49	0	43	0	169	223	0	0	703
16:30	0	0	0	0	0	185	74	0	56	0	38	0	159	220	0	0	732
16:45	0	0	0	0	0	198	50	0	60	0	44	0	155	209	0	0	716
Total	0	0	0	0	0	728	245	0	227	0	177	0	676	851	0	0	2904
17:00	0	0	0	0	0	204	68	0	66	0	50	0	162	227	0	0	777
17:15	0	0	0	0	0	226	60	0	48	0	60	0	163	244	0	0	801
17:30	0	0	0	0	0	169	39	0	53	0	57	0	137	236	0	0	691
17:45	0	0	0	0	0	153	43	0	71	0	71	0	133	242	0	0	713
Total	0	0	0	0	0	752	210	0	238	0	238	0	595	949	0	0	2982
Grand Total	0	0	0	0	0	5313	1992	0	1609	3	1426	0	4278	6876	0	0	21497
Apprch %	0	0	0	0	0	72.7	27.3	0	53	0.1	46.9	0	38.4	61.6	0	0	
Total %	0	0	0	0	0	24.7	9.3	0	7.5	0	6.6	0	19.9	32	0	0	



# MINNESOTA DEPT OF TRANSPORTATION

## TRAFFIC DATA COLLECTION - METRO

TH-7 at TH-100, East Ramps  
 ref.pt.: 194.248  
 collected by: ALLIANT CONSULT.  
 TURN MOVEMENT COUNT

File Name : TH-7 at TH-100 East Ramps 2007  
 Site Code : 00000168  
 Start Date : 12/12/2007  
 Page No : 3

Start Time	ramp to NB TH-100 Southbound					CSAH-25 Westbound					ramp from NB TH-100 Northbound					TH-7 Eastbound					Int. Total
	Left	Thru	Right	Peds	App. Total	Left	Thru	Right	Peds	App. Total	Left	Thru	Right	Peds	App. Total	Left	Thru	Right	Peds	App. Total	
Peak Hour Analysis From 06:00 to 09:15 - Peak 1 of 1																					
Peak Hour for Entire Intersection Begins at 07:30																					
07:30	0	0	0	0	0	0	198	59	0	257	25	0	32	0	57	147	243	0	0	390	704
07:45	0	0	0	0	0	0	170	70	0	240	27	0	22	0	49	150	300	0	0	450	739
08:00	0	0	0	0	0	0	156	48	0	204	17	0	22	0	39	157	204	0	0	361	604
08:15	0	0	0	0	0	0	160	49	0	209	18	0	25	0	43	162	220	0	0	382	634
Total Volume	0	0	0	0	0	0	684	226	0	910	87	0	101	0	188	616	967	0	0	1583	2681
% App. Total																					
PHF	.000	.000	.000	.000	.000	.000	.864	.807	.000	.885	.806	.000	.789	.000	.825	.951	.806	.000	.000	.879	.907

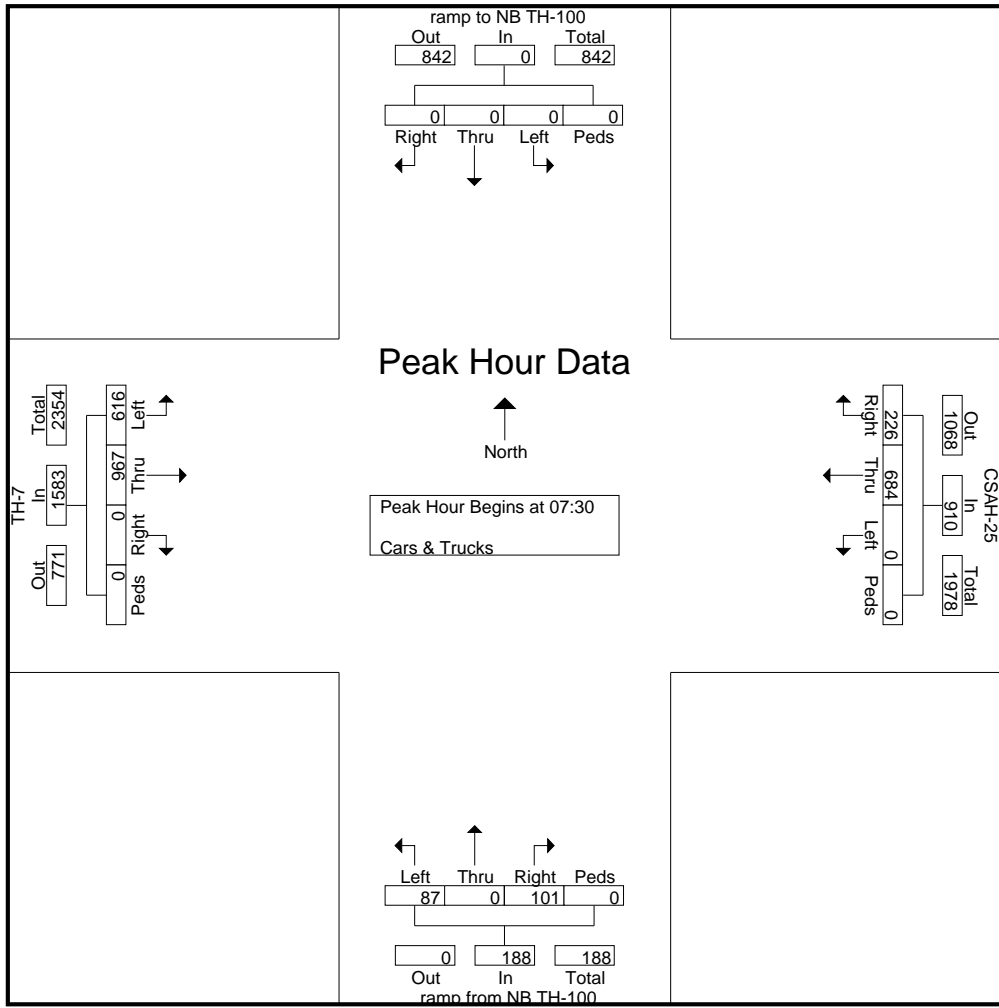



# MINNESOTA DEPT OF TRANSPORTATION

## TRAFFIC DATA COLLECTION - METRO

TH-7 at TH-100, East Ramps

ref.pt.: 194.248

collected by: ALLIANT CONSULT.

TURN MOVEMENT COUNT

File Name : TH-7 at TH-100 East Ramps 2007

Site Code : 00000168

Start Date : 12/12/2007

Page No : 4

Start Time	ramp to NB TH-100 Southbound					CSAH-25 Westbound					ramp from NB TH-100 Northbound					TH-7 Eastbound					Int. Total
	Left	Thru	Right	Peds	App. Total	Left	Thru	Right	Peds	App. Total	Left	Thru	Right	Peds	App. Total	Left	Thru	Right	Peds	App. Total	
Peak Hour Analysis From 14:30 to 17:45 - Peak 1 of 1																					
Peak Hour for Entire Intersection Begins at 16:30																					
16:30	0	0	0	0	0	0	185	74	0	259	56	0	38	0	94	159	220	0	0	379	732
16:45	0	0	0	0	0	0	198	50	0	248	60	0	44	0	104	155	209	0	0	364	716
17:00	0	0	0	0	0	0	204	68	0	272	66	0	50	0	116	162	227	0	0	389	777
17:15	0	0	0	0	0	0	226	60	0	286	48	0	60	0	108	163	244	0	0	407	801
Total Volume	0	0	0	0	0	0	813	252	0	1065	230	0	192	0	422	639	900	0	0	1539	3026
% App. Total																					
PHF	.000	.000	.000	.000	.000	.000	.899	.851	.000	.931	.871	.000	.800	.000	.909	.980	.922	.000	.000	.945	.944

