

Alliant Engineering Inc Minneapolis, MN 55415

CSAH-25 at Ottawa Ave / Belt Line Blvd
 Ref.Pt.: CSAH-25 = old Hwy 7
 Alliant Engineering Inc
 TURN MOVEMENT COUNT

File Name : 29_CR 25 at Ottawa Ave_010611
 Site Code : 00000029
 Start Date : 1/6/2011
 Page No : 1

Groups Printed- Unshifted - Bank 1

Start Time	Ottawa Ave S Southbound				CSAH-25 (old Hwy 7) Westbound				Belt Line Blvd Northbound				CSAH-25 (old Hwy 7) Eastbound				Int. Total
	Left	Thru	Rght	Peds	Left	Thru	Rght	Peds	Left	Thru	Rght	Peds	Left	Thru	Rght	Peds	
06:00	0	4	4	0	4	25	0	1	7	1	4	0	1	31	28	0	110
06:15	2	10	8	0	6	31	0	0	13	3	3	0	2	48	36	0	162
06:30	2	8	5	0	15	67	0	0	22	3	7	0	4	65	49	0	247
06:45	0	7	18	0	24	89	0	0	29	4	10	0	4	73	65	0	323
Total	4	29	35	0	49	212	0	1	71	11	24	0	11	217	178	0	842
07:00	0	7	11	0	9	77	0	0	37	14	13	0	3	109	40	0	320
07:15	0	11	17	0	12	125	0	0	47	27	19	0	6	113	67	0	444
07:30	2	20	23	0	26	163	0	0	57	26	16	0	26	143	61	0	563
07:45	1	19	28	0	35	181	1	0	58	46	23	0	34	162	79	0	667
Total	3	57	79	0	82	546	1	0	199	113	71	0	69	527	247	0	1994
08:00	1	22	24	0	34	174	1	0	50	35	35	1	5	144	70	0	596
08:15	3	23	24	0	22	155	3	1	42	28	25	0	10	151	67	0	554
08:30	2	19	13	0	24	148	0	1	42	26	41	0	10	146	84	0	556
08:45	1	17	20	0	24	136	0	1	37	18	23	0	10	110	75	0	472
Total	7	81	81	0	104	613	4	3	171	107	124	1	35	551	296	0	2178
09:00	1	15	18	0	20	111	1	0	35	13	18	0	13	113	63	0	421
09:15	4	17	11	0	36	91	0	0	40	11	23	0	9	104	44	0	390
*** BREAK ***																	
Total	5	32	29	0	56	202	1	0	75	24	41	0	22	217	107	0	811
*** BREAK ***																	
10:30	3	20	17	0	18	70	2	0	29	11	18	0	8	79	46	0	321
10:45	0	13	10	0	21	90	1	1	33	21	23	0	1	100	38	0	352
Total	3	33	27	0	39	160	3	1	62	32	41	0	9	179	84	0	673
11:00	0	20	12	0	23	57	1	0	40	23	26	0	6	90	41	0	339
11:15	1	15	8	0	26	99	0	1	39	14	20	0	11	93	36	0	363
11:30	1	24	13	0	22	79	1	0	39	15	27	0	6	92	50	0	369
11:45	0	16	13	0	26	83	3	0	47	21	18	0	10	127	40	0	404
Total	2	75	46	0	97	318	5	1	165	73	91	0	33	402	167	0	1475
12:00	0	14	8	0	22	97	2	0	45	18	18	0	10	93	38	0	365
12:15	3	11	12	0	28	102	5	0	39	16	24	0	9	106	35	0	390
12:30	2	16	16	0	17	90	4	0	29	23	16	0	20	124	44	0	401
12:45	0	23	18	0	20	101	1	0	23	14	27	0	11	123	45	0	406
Total	5	64	54	0	87	390	12	0	136	71	85	0	50	446	162	0	1562
13:00	0	18	12	0	29	72	3	0	31	12	19	0	13	109	49	0	367
13:15	3	16	8	0	25	105	0	0	38	14	26	0	8	115	44	0	402
*** BREAK ***																	
Total	3	34	20	0	54	177	3	0	69	26	45	0	21	224	93	0	769
*** BREAK ***																	
14:30	2	21	11	0	36	98	2	0	53	29	23	0	10	124	59	0	468
14:45	2	38	7	0	39	116	0	0	53	23	24	0	11	138	56	0	507
Total	4	59	18	0	75	214	2	0	106	52	47	0	21	262	115	0	975
15:00	2	40	19	0	23	114	2	0	87	39	46	0	12	115	40	0	539
15:15	0	23	12	0	29	141	3	1	58	26	35	0	14	119	56	1	518
15:30	1	27	6	0	33	129	1	1	62	45	34	0	7	136	55	0	537
15:45	0	23	8	0	21	141	1	0	61	51	40	0	21	156	54	0	577
Total	3	113	45	0	106	525	7	2	268	161	155	0	54	526	205	1	2171

Alliant Engineering Inc Minneapolis, MN 55415

CSAH-25 at Ottawa Ave / Belt Line Blvd
 Ref.Pt.: CSAH-25 = old Hwy 7
 Alliant Engineering Inc
 TURN MOVEMENT COUNT

File Name : 29_CR 25 at Ottawa Ave_010611
 Site Code : 00000029
 Start Date : 1/6/2011
 Page No : 2

Groups Printed- Unshifted - Bank 1

Start Time	Ottawa Ave S Southbound				CSAH-25 (old Hwy 7) Westbound				Belt Line Blvd Northbound				CSAH-25 (old Hwy 7) Eastbound				Int. Total
	Left	Thru	Rght	Peds	Left	Thru	Rght	Peds	Left	Thru	Rght	Peds	Left	Thru	Rght	Peds	
16:00	1	26	7	0	18	116	1	1	65	47	45	0	15	156	42	0	540
16:15	3	34	14	0	30	137	2	0	50	62	46	0	17	149	41	0	585
16:30	0	25	15	0	32	130	2	0	75	60	49	0	16	181	68	0	653
16:45	1	32	13	0	42	145	3	1	49	65	47	0	12	208	54	0	672
Total	5	117	49	0	122	528	8	2	239	234	187	0	60	694	205	0	2450
17:00	0	36	13	0	45	138	0	0	74	69	66	0	17	197	71	0	726
17:15	2	34	8	0	28	142	3	0	75	70	49	0	19	215	50	0	695
17:30	3	29	18	0	66	148	1	0	59	51	50	0	21	233	68	0	747
17:45	2	24	13	0	42	104	2	0	47	46	35	0	24	251	64	0	654
Total	7	123	52	0	181	532	6	0	255	236	200	0	81	896	253	0	2822
Grand Total	51	817	535	0	1052	4417	52	10	1816	1140	1111	1	466	5141	2112	1	18722
Apprch %	3.6	58.2	38.1	0	19	79.9	0.9	0.2	44.6	28	27.3	0	6	66.6	27.4	0	
Total %	0.3	4.4	2.9	0	5.6	23.6	0.3	0.1	9.7	6.1	5.9	0	2.5	27.5	11.3	0	
Unshifted	50	797	524	0	1036	4332	50	10	1734	1117	1081	1	458	5054	2019	1	18264
% Unshifted	98	97.6	97.9	0	98.5	98.1	96.2	100	95.5	98	97.3	100	98.3	98.3	95.6	100	97.6
Bank 1	1	20	11	0	16	85	2	0	82	23	30	0	8	87	93	0	458
% Bank 1	2	2.4	2.1	0	1.5	1.9	3.8	0	4.5	2	2.7	0	1.7	1.7	4.4	0	2.4

Alliant Engineering Inc Minneapolis, MN 55415

CSAH-25 at Ottawa Ave / Belt Line Blvd
 Ref.Pt.: CSAH-25 = old Hwy 7
 Alliant Engineering Inc
 TURN MOVEMENT COUNT

File Name : 29_CR 25 at Ottawa Ave_010611
 Site Code : 00000029
 Start Date : 1/6/2011
 Page No : 3

Start Time	Ottawa Ave S Southbound					CSAH-25 (old Hwy 7) Westbound					Belt Line Blvd Northbound					CSAH-25 (old Hwy 7) Eastbound					Int. Total
	Left	Thru	Rght	Peds	App. Total	Left	Thru	Rght	Peds	App. Total	Left	Thru	Rght	Peds	App. Total	Left	Thru	Rght	Peds	App. Total	
Peak Hour Analysis From 06:00 to 09:15 - Peak 1 of 1																					
Peak Hour for Entire Intersection Begins at 07:30																					
07:30	2	20	23	0	45	26	163	0	0	189	57	26	16	0	99	26	143	61	0	230	563
07:45	1	19	28	0	48	35	181	1	0	217	58	46	23	0	127	34	162	79	0	275	667
08:00	1	22	24	0	47	34	174	1	0	209	50	35	35	1	121	5	144	70	0	219	596
08:15	3	23	24	0	50	22	155	3	1	181	42	28	25	0	95	10	151	67	0	228	554
Total Volume	7	84	99	0	190	117	673	5	1	796	207	135	99	1	442	75	600	277	0	952	2380
% App. Total	3.7	44.2	52.1	0		14.7	84.5	0.6	0.1		46.8	30.5	22.4	0.2		7.9	63	29.1	0		
PHF	.583	.913	.884	.000	.950	.836	.930	.417	.250	.917	.892	.734	.707	.250	.870	.551	.926	.877	.000	.865	.892

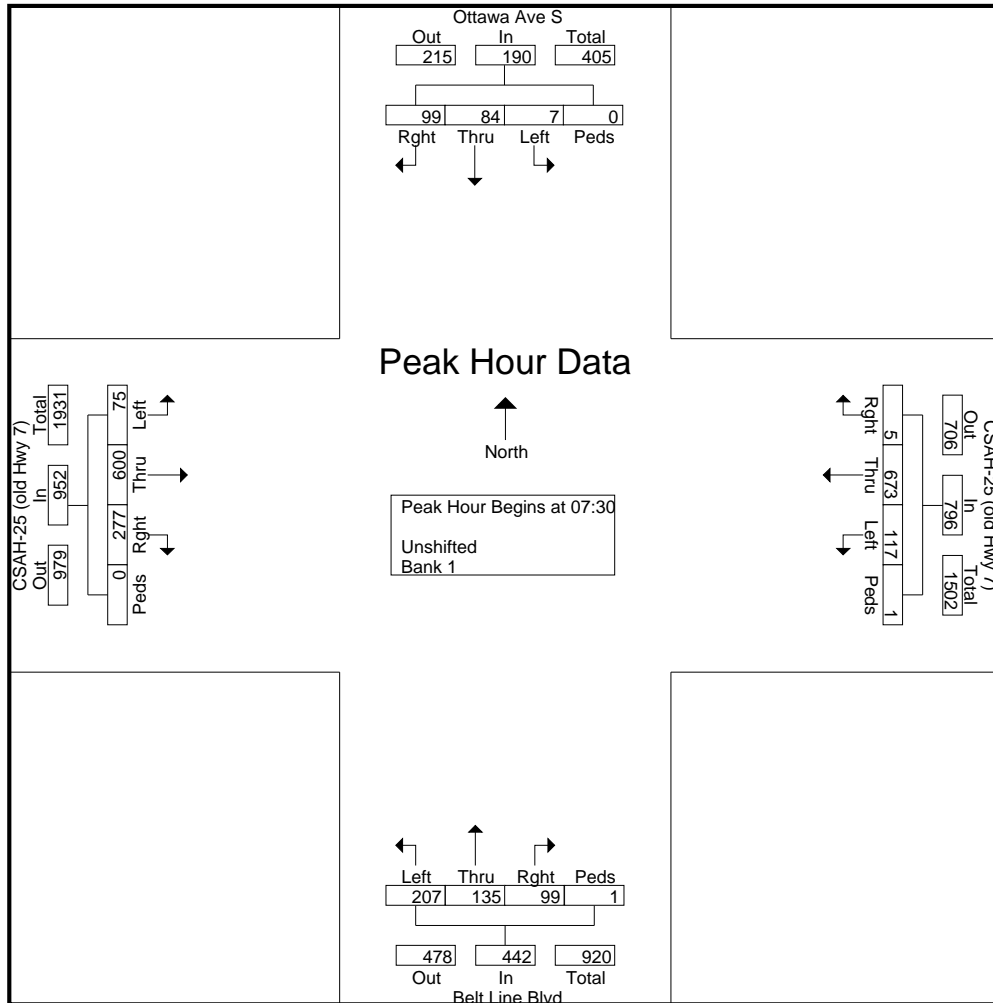

Alliant Engineering Inc Minneapolis, MN 55415

CSAH-25 at Ottawa Ave / Belt Line Blvd
 Ref.Pt.: CSAH-25 = old Hwy 7
 Alliant Engineering Inc
 TURN MOVEMENT COUNT

File Name : 29_CR 25 at Ottawa Ave_010611
 Site Code : 00000029
 Start Date : 1/6/2011
 Page No : 4

Start Time	Ottawa Ave S Southbound					CSAH-25 (old Hwy 7) Westbound					Belt Line Blvd Northbound					CSAH-25 (old Hwy 7) Eastbound					Int. Total
	Left	Thru	Rght	Peds	App. Total	Left	Thru	Rght	Peds	App. Total	Left	Thru	Rght	Peds	App. Total	Left	Thru	Rght	Peds	App. Total	
Peak Hour Analysis From 14:30 to 17:45 - Peak 1 of 1																					
Peak Hour for Entire Intersection Begins at 16:45																					
16:45	1	32	13	0	46	42	145	3	1	191	49	65	47	0	161	12	208	54	0	274	672
17:00	0	36	13	0	49	45	138	0	0	183	74	69	66	0	209	17	197	71	0	285	726
17:15	2	34	8	0	44	28	142	3	0	173	75	70	49	0	194	19	215	50	0	284	695
17:30	3	29	18	0	50	66	148	1	0	215	59	51	50	0	160	21	233	68	0	322	747
Total Volume	6	131	52	0	189	181	573	7	1	762	257	255	212	0	724	69	853	243	0	1165	2840
% App. Total	3.2	69.3	27.5	0		23.8	75.2	0.9	0.1		35.5	35.2	29.3	0		5.9	73.2	20.9	0		
PHF	.500	.910	.722	.000	.945	.686	.968	.583	.250	.886	.857	.911	.803	.000	.866	.821	.915	.856	.000	.905	.950

