

Alliant Engineering Inc Minneapolis, MN 55415

TH-7 at Louisiana Ave S.
Ref.Pt.: 193.050
Alliant Engineering Inc
TURN MOVEMENT COUNT

File Name : 24_TH 7 at Louisiana Ave_011111
Site Code : 00000024
Start Date : 1/11/2011
Page No : 1

Groups Printed- Unshifted - Bank 1

Start Time	Louisiana Ave S Southbound				TH-7 Westbound				Louisiana Ave S Northbound				TH-7 Eastbound				Int. Total
	Left	Thru	Right	Peds	Left	Thru	Right	Peds	Left	Thru	Right	Peds	Left	Thru	Right	Peds	
06:00	8	8	2	0	29	39	1	0	5	2	7	0	7	64	46	0	218
06:15	18	16	5	0	32	76	4	0	4	10	7	0	9	73	93	0	347
06:30	17	15	10	0	64	102	5	0	5	12	4	0	10	120	104	0	468
06:45	18	34	8	0	57	114	5	0	10	14	4	0	34	156	111	1	566
Total	61	73	25	0	182	331	15	0	24	38	22	0	60	413	354	1	1599
07:00	34	26	7	0	59	139	15	0	12	34	2	0	44	195	56	0	623
07:15	48	22	7	0	31	169	12	0	14	18	1	0	39	251	52	0	664
07:30	53	49	16	0	50	227	15	0	27	11	2	0	51	246	34	0	781
07:45	55	41	11	0	66	269	19	0	19	38	1	0	48	257	40	0	864
Total	190	138	41	0	206	804	61	0	72	101	6	0	182	949	182	0	2932
08:00	32	23	8	0	54	208	10	0	26	42	6	0	54	284	38	0	785
08:15	33	27	5	0	58	184	13	0	22	30	3	0	58	195	43	0	671
08:30	34	32	10	1	42	160	17	0	20	21	0	0	43	213	46	1	640
08:45	32	29	11	0	42	195	17	0	27	32	1	0	44	226	60	0	716
Total	131	111	34	1	196	747	57	0	95	125	10	0	199	918	187	1	2812
09:00	28	39	7	0	46	148	12	0	29	32	2	0	33	176	41	0	593
09:15	24	28	10	0	47	135	14	0	20	23	3	0	27	161	44	0	536
*** BREAK ***																	
Total	52	67	17	0	93	283	26	0	49	55	5	0	60	337	85	0	1129
*** BREAK ***																	
10:30	17	35	14	0	39	110	7	0	41	47	6	0	34	155	48	0	553
10:45	11	24	11	0	31	130	10	0	39	26	5	0	23	106	30	0	446
Total	28	59	25	0	70	240	17	0	80	73	11	0	57	261	78	0	999
11:00	16	17	12	0	31	104	9	0	48	39	9	0	30	110	30	0	455
11:15	18	20	19	0	32	130	9	0	60	28	4	0	16	177	33	0	546
11:30	15	7	16	0	18	127	18	0	62	49	9	0	51	120	27	0	519
11:45	23	33	22	0	61	175	17	1	66	32	4	0	40	151	29	0	654
Total	72	77	69	0	142	536	53	1	236	148	26	0	137	558	119	0	2174
12:00	9	19	20	1	30	172	13	0	55	42	2	0	31	179	32	0	605
12:15	23	24	19	0	49	183	18	0	52	40	2	0	63	129	33	0	635
12:30	19	29	13	0	49	187	13	0	53	43	5	0	42	141	55	0	649
12:45	26	33	28	0	32	149	14	0	69	50	2	0	44	128	16	0	591
Total	77	105	80	1	160	691	58	0	229	175	11	0	180	577	136	0	2480
13:00	11	31	17	0	37	177	14	0	47	54	5	0	42	174	38	0	647
13:15	17	42	15	0	33	194	15	0	52	54	3	0	43	166	33	0	667
*** BREAK ***																	
Total	28	73	32	0	70	371	29	0	99	108	8	0	85	340	71	0	1314
*** BREAK ***																	
14:30	18	39	15	0	52	198	29	0	78	58	7	0	29	165	47	1	736
14:45	25	27	21	0	55	203	15	0	67	35	12	0	48	196	56	2	762
Total	43	66	36	0	107	401	44	0	145	93	19	0	77	361	103	3	1498
15:00	27	45	32	0	46	216	20	0	86	55	57	0	24	162	49	0	819
15:15	13	34	30	0	52	238	34	1	84	40	36	0	36	170	36	0	804
15:30	20	22	25	0	34	232	26	0	94	68	41	0	37	183	39	1	822
15:45	22	37	21	0	34	255	21	0	89	58	41	0	47	267	45	0	937
Total	82	138	108	0	166	941	101	1	353	221	175	0	144	782	169	1	3382

Alliant Engineering Inc Minneapolis, MN 55415

TH-7 at Louisiana Ave S.
Ref.Pt.: 193.050
Alliant Engineering Inc
TURN MOVEMENT COUNT

File Name : 24_TH 7 at Louisiana Ave_011111
Site Code : 00000024
Start Date : 1/11/2011
Page No : 2

Groups Printed- Unshifted - Bank 1

Start Time	Louisiana Ave S Southbound				TH-7 Westbound				Louisiana Ave S Northbound				TH-7 Eastbound				Int. Total
	Left	Thru	Right	Peds	Left	Thru	Right	Peds	Left	Thru	Right	Peds	Left	Thru	Right	Peds	
16:00	20	22	31	0	42	262	25	0	63	73	61	0	48	285	42	0	974
16:15	24	25	27	0	37	239	24	0	72	57	32	0	37	286	32	0	892
16:30	31	37	29	0	27	220	38	0	77	78	69	0	48	270	33	0	957
16:45	19	31	28	0	43	260	37	0	67	72	32	0	65	335	30	0	1019
Total	94	115	115	0	149	981	124	0	279	280	194	0	198	1176	137	0	3842
17:00	29	35	27	1	43	259	47	0	86	75	37	0	44	356	31	1	1071
17:15	26	29	11	0	47	280	52	0	78	83	23	0	72	341	28	0	1070
17:30	28	43	19	0	35	259	37	1	67	69	25	0	111	320	38	0	1052
17:45	19	33	17	0	49	269	47	0	52	56	19	0	88	380	46	0	1075
Total	102	140	74	1	174	1067	183	1	283	283	104	0	315	1397	143	1	4268
Grand Total	960	1162	656	3	1715	7393	768	3	1944	1700	591	0	1694	8069	1764	7	28429
Apprch %	34.5	41.8	23.6	0.1	17.4	74.8	7.8	0	45.9	40.1	14	0	14.7	70	15.3	0.1	
Total %	3.4	4.1	2.3	0	6	26	2.7	0	6.8	6	2.1	0	6	28.4	6.2	0	
Unshifted	932	1108	646	3	1641	7272	735	3	1904	1633	576	0	1664	7952	1724	7	27800
% Unshifted	97.1	95.4	98.5	100	95.7	98.4	95.7	100	97.9	96.1	97.5	0	98.2	98.6	97.7	100	97.8
Bank 1	28	54	10	0	74	121	33	0	40	67	15	0	30	117	40	0	629
% Bank 1	2.9	4.6	1.5	0	4.3	1.6	4.3	0	2.1	3.9	2.5	0	1.8	1.4	2.3	0	2.2

Alliant Engineering Inc Minneapolis, MN 55415

TH-7 at Louisiana Ave S.
Ref.Pt.: 193.050
Alliant Engineering Inc
TURN MOVEMENT COUNT

File Name : 24_TH 7 at Louisiana Ave_011111
Site Code : 00000024
Start Date : 1/11/2011
Page No : 3

Start Time	Louisiana Ave S Southbound					TH-7 Westbound					Louisiana Ave S Northbound					TH-7 Eastbound					Int. Total
	Left	Thru	Right	Peds	App. Total	Left	Thru	Right	Peds	App. Total	Left	Thru	Right	Peds	App. Total	Left	Thru	Right	Peds	App. Total	
Peak Hour Analysis From 06:00 to 09:15 - Peak 1 of 1																					
Peak Hour for Entire Intersection Begins at 07:30																					
07:30	53	49	16	0	118	50	227	15	0	292	27	11	2	0	40	51	246	34	0	331	781
07:45	55	41	11	0	107	66	269	19	0	354	19	38	1	0	58	48	257	40	0	345	864
08:00	32	23	8	0	63	54	208	10	0	272	26	42	6	0	74	54	284	38	0	376	785
08:15	33	27	5	0	65	58	184	13	0	255	22	30	3	0	55	58	195	43	0	296	671
Total Volume	173	140	40	0	353	228	888	57	0	1173	94	121	12	0	227	211	982	155	0	1348	3101
% App. Total	49	39.7	11.3	0		19.4	75.7	4.9	0		41.4	53.3	5.3	0		15.7	72.8	11.5	0		
PHF	.786	.714	.625	.000	.748	.864	.825	.750	.000	.828	.870	.720	.500	.000	.767	.909	.864	.901	.000	.896	.897

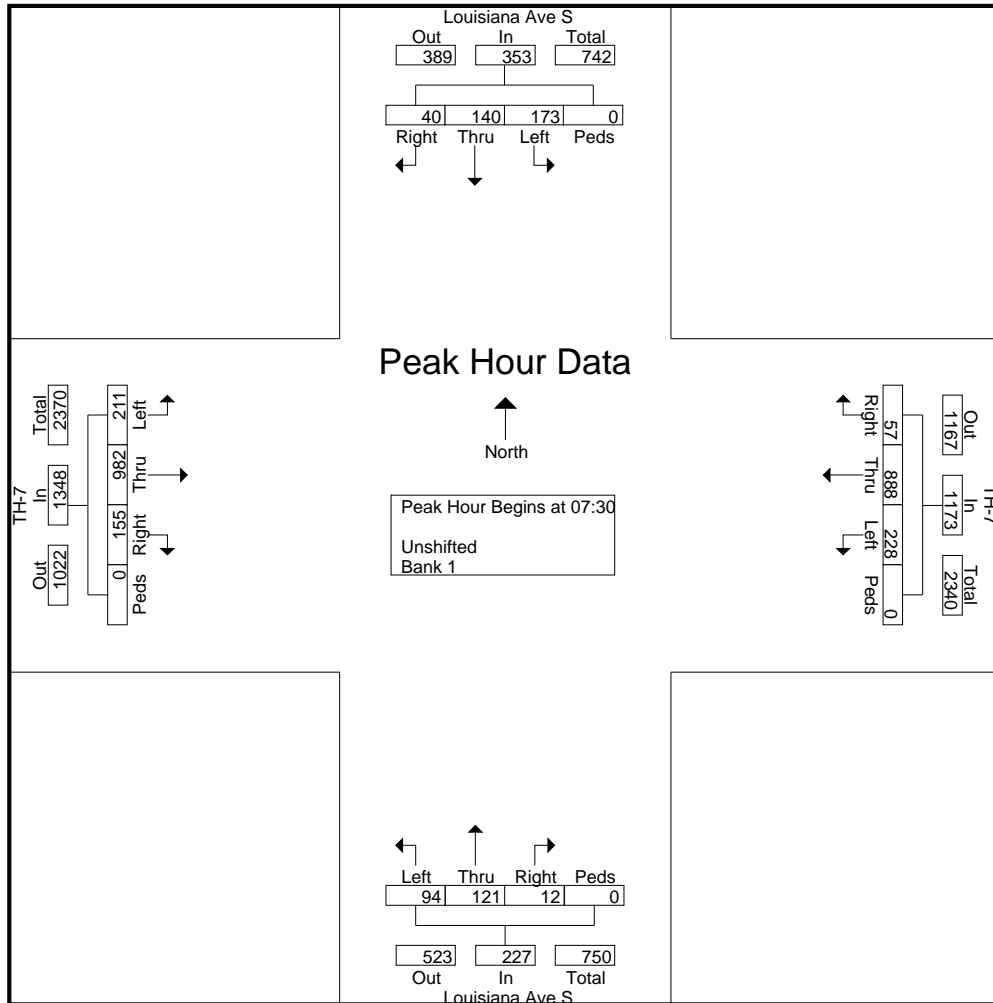

Alliant Engineering Inc Minneapolis, MN 55415

TH-7 at Louisiana Ave S.
Ref.Pt.: 193.050
Alliant Engineering Inc
TURN MOVEMENT COUNT

File Name : 24_TH 7 at Louisiana Ave_011111
Site Code : 00000024
Start Date : 1/11/2011
Page No : 4

Start Time	Louisiana Ave S Southbound					TH-7 Westbound					Louisiana Ave S Northbound					TH-7 Eastbound					Int. Total
	Left	Thru	Right	Peds	App. Total	Left	Thru	Right	Peds	App. Total	Left	Thru	Right	Peds	App. Total	Left	Thru	Right	Peds	App. Total	
Peak Hour Analysis From 14:30 to 17:45 - Peak 1 of 1																					
Peak Hour for Entire Intersection Begins at 17:00																					
17:00	29	35	27	1	92	43	259	47	0	349	86	75	37	0	198	44	356	31	1	432	1071
17:15	26	29	11	0	66	47	280	52	0	379	78	83	23	0	184	72	341	28	0	441	1070
17:30	28	43	19	0	90	35	259	37	1	332	67	69	25	0	161	111	320	38	0	469	1052
17:45	19	33	17	0	69	49	269	47	0	365	52	56	19	0	127	88	380	46	0	514	1075
Total Volume	102	140	74	1	317	174	1067	183	1	1425	283	283	104	0	670	315	1397	143	1	1856	4268
% App. Total	32.2	44.2	23.3	0.3		12.2	74.9	12.8	0.1		42.2	42.2	15.5	0		17	75.3	7.7	0.1		
PHF	.879	.814	.685	.250	.861	.888	.953	.880	.250	.940	.823	.852	.703	.000	.846	.709	.919	.777	.250	.903	.993

