

Alliant Engineering Inc Minneapolis, MN 55415

TH-7 at Texas Ave S
Ref.Pt.: 192.486
Alliant Engineering Inc
TURN MOVEMENT COUNT

File Name : 23_TH 7 at Texas Ave_011111
Site Code : 00000023
Start Date : 1/11/2011
Page No : 1

Groups Printed- Unshifted - Bank 1

Start Time	Texas Ave S Southbound				TH-7 Westbound				Texas Ave S Northbound				TH-7 Eastbound				Int. Total
	Left	Thru	Right	Peds	Left	Thru	Right	Peds	Left	Thru	Right	Peds	Left	Thru	Right	Peds	
06:00	14	1	6	0	0	46	6	1	1	2	8	0	5	89	1	0	180
06:15	13	2	7	0	2	57	12	0	4	1	5	0	7	156	6	0	272
06:30	17	2	4	0	0	104	12	0	7	2	8	0	5	159	4	0	324
06:45	20	3	20	0	1	133	10	0	5	3	1	0	5	286	3	0	490
Total	64	8	37	0	3	340	40	1	17	8	22	0	22	690	14	0	1266
07:00	24	1	30	0	1	142	10	0	6	6	10	0	10	212	7	0	459
07:15	26	2	13	0	1	177	11	0	8	2	7	0	12	288	3	0	550
07:30	23	2	31	0	3	255	9	0	6	8	6	0	22	323	1	0	689
07:45	30	12	39	0	4	321	20	1	8	10	6	0	26	367	3	0	847
Total	103	17	113	0	9	895	50	1	28	26	29	0	70	1190	14	0	2545
08:00	22	8	30	0	4	337	14	0	14	4	2	0	23	363	7	1	829
08:15	28	7	17	0	3	251	22	0	5	3	5	0	34	298	3	0	676
08:30	25	9	28	0	2	261	13	0	9	3	8	0	29	359	3	0	749
08:45	22	8	26	0	2	281	14	0	6	6	3	0	23	364	4	0	759
Total	97	32	101	0	11	1130	63	0	34	16	18	0	109	1384	17	1	3013
09:00	31	10	28	0	10	218	24	0	7	9	6	0	27	315	3	0	688
09:15	16	5	12	0	2	186	14	0	4	3	1	0	20	239	5	0	507
*** BREAK ***																	
Total	47	15	40	0	12	404	38	0	11	12	7	0	47	554	8	0	1195
*** BREAK ***																	
10:30	22	4	24	0	3	192	22	0	4	2	4	0	15	179	5	0	476
10:45	20	1	26	1	6	171	17	0	5	4	4	0	25	134	4	0	418
Total	42	5	50	1	9	363	39	0	9	6	8	0	40	313	9	0	894
11:00	25	5	22	0	8	200	30	0	20	1	7	0	23	131	7	0	479
11:15	28	2	30	1	7	223	24	0	9	7	6	0	22	185	18	0	562
11:30	22	4	32	0	5	193	18	0	8	9	6	0	21	159	4	2	483
11:45	33	11	44	0	3	207	38	0	12	4	7	0	27	153	5	0	544
Total	108	22	128	1	23	823	110	0	49	21	26	0	93	628	34	2	2068
12:00	34	13	49	0	9	224	35	1	8	5	5	0	27	150	7	3	570
12:15	32	0	39	0	3	162	38	0	11	2	5	0	30	180	8	0	510
12:30	51	15	30	0	1	223	29	0	8	7	6	0	29	160	2	0	561
12:45	54	3	48	0	2	201	34	0	7	3	7	0	35	185	2	0	581
Total	171	31	166	0	15	810	136	1	34	17	23	0	121	675	19	3	2222
13:00	43	1	14	0	3	184	33	2	5	1	0	0	39	160	6	0	491
13:15	30	9	36	0	4	183	27	0	12	4	4	0	45	208	9	1	572
*** BREAK ***																	
Total	73	10	50	0	7	367	60	2	17	5	4	0	84	368	15	1	1063
*** BREAK ***																	
14:30	36	13	32	0	5	279	44	1	7	3	8	0	17	205	10	0	660
14:45	41	7	17	0	0	242	38	0	5	10	7	0	43	227	7	0	644
Total	77	20	49	0	5	521	82	1	12	13	15	0	60	432	17	0	1304
15:00	40	12	41	0	5	271	38	0	12	7	5	0	33	183	4	0	651
15:15	28	13	38	0	8	315	33	0	7	7	5	0	44	196	8	1	703
15:30	37	12	50	0	5	323	38	0	11	9	2	0	32	234	6	0	759
15:45	35	17	34	0	7	328	48	0	8	9	14	0	31	281	6	0	818
Total	140	54	163	0	25	1237	157	0	38	32	26	0	140	894	24	1	2931

Alliant Engineering Inc Minneapolis, MN 55415

TH-7 at Texas Ave S
Ref.Pt.: 192.486
Alliant Engineering Inc
TURN MOVEMENT COUNT

File Name : 23_TH 7 at Texas Ave_011111
Site Code : 00000023
Start Date : 1/11/2011
Page No : 2

Groups Printed- Unshifted - Bank 1

Start Time	Texas Ave S Southbound				TH-7 Westbound				Texas Ave S Northbound				TH-7 Eastbound				Int. Total
	Left	Thru	Right	Peds	Left	Thru	Right	Peds	Left	Thru	Right	Peds	Left	Thru	Right	Peds	
16:00	26	8	37	0	6	255	55	0	15	14	6	0	47	286	15	1	771
16:15	33	13	41	0	8	326	50	0	5	9	6	0	58	291	4	0	844
16:30	32	16	43	0	5	263	46	0	7	8	11	0	42	303	3	0	779
16:45	43	23	27	0	4	319	48	1	13	17	10	0	69	360	16	0	950
Total	134	60	148	0	23	1163	199	1	40	48	33	0	216	1240	38	1	3344
17:00	48	19	37	0	6	289	45	0	7	22	7	0	68	348	10	0	906
17:15	42	25	49	0	9	353	62	0	8	5	11	0	72	420	12	0	1068
17:30	45	25	55	0	3	315	52	0	7	17	11	0	88	419	22	1	1060
17:45	53	20	59	0	6	300	46	1	7	7	8	0	65	386	10	0	968
Total	188	89	200	0	24	1257	205	1	29	51	37	0	293	1573	54	1	4002
Grand Total	1244	363	1245	2	166	9310	1179	8	318	255	248	0	1295	9941	263	10	25847
Apprch %	43.6	12.7	43.6	0.1	1.6	87.3	11.1	0.1	38.7	31.1	30.2	0	11.3	86.4	2.3	0.1	
Total %	4.8	1.4	4.8	0	0.6	36	4.6	0	1.2	1	1	0	5	38.5	1	0	
Unshifted	1231	351	1210	2	165	9125	1154	8	306	242	240	0	1278	9787	255	10	25364
% Unshifted	99	96.7	97.2	100	99.4	98	97.9	100	96.2	94.9	96.8	0	98.7	98.5	97	100	98.1
Bank 1	13	12	35	0	1	185	25	0	12	13	8	0	17	154	8	0	483
% Bank 1	1	3.3	2.8	0	0.6	2	2.1	0	3.8	5.1	3.2	0	1.3	1.5	3	0	1.9

Alliant Engineering Inc Minneapolis, MN 55415

TH-7 at Texas Ave S
Ref.Pt.: 192.486
Alliant Engineering Inc
TURN MOVEMENT COUNT

File Name : 23_TH 7 at Texas Ave_011111
Site Code : 00000023
Start Date : 1/11/2011
Page No : 3

Start Time	Texas Ave S Southbound					TH-7 Westbound					Texas Ave S Northbound					TH-7 Eastbound					Int. Total
	Left	Thru	Right	Peds	App. Total	Left	Thru	Right	Peds	App. Total	Left	Thru	Right	Peds	App. Total	Left	Thru	Right	Peds	App. Total	
Peak Hour Analysis From 06:00 to 09:15 - Peak 1 of 1																					
Peak Hour for Entire Intersection Begins at 07:45																					
07:45	30	12	39	0	81	4	321	20	1	346	8	10	6	0	24	26	367	3	0	396	847
08:00	22	8	30	0	60	4	337	14	0	355	14	4	2	0	20	23	363	7	1	394	829
08:15	28	7	17	0	52	3	251	22	0	276	5	3	5	0	13	34	298	3	0	335	676
08:30	25	9	28	0	62	2	261	13	0	276	9	3	8	0	20	29	359	3	0	391	749
Total Volume	105	36	114	0	255	13	1170	69	1	1253	36	20	21	0	77	112	1387	16	1	1516	3101
% App. Total	41.2	14.1	44.7	0		1	93.4	5.5	0.1		46.8	26	27.3	0		7.4	91.5	1.1	0.1		
PHF	.875	.750	.731	.000	.787	.813	.868	.784	.250	.882	.643	.500	.656	.000	.802	.824	.945	.571	.250	.957	.915

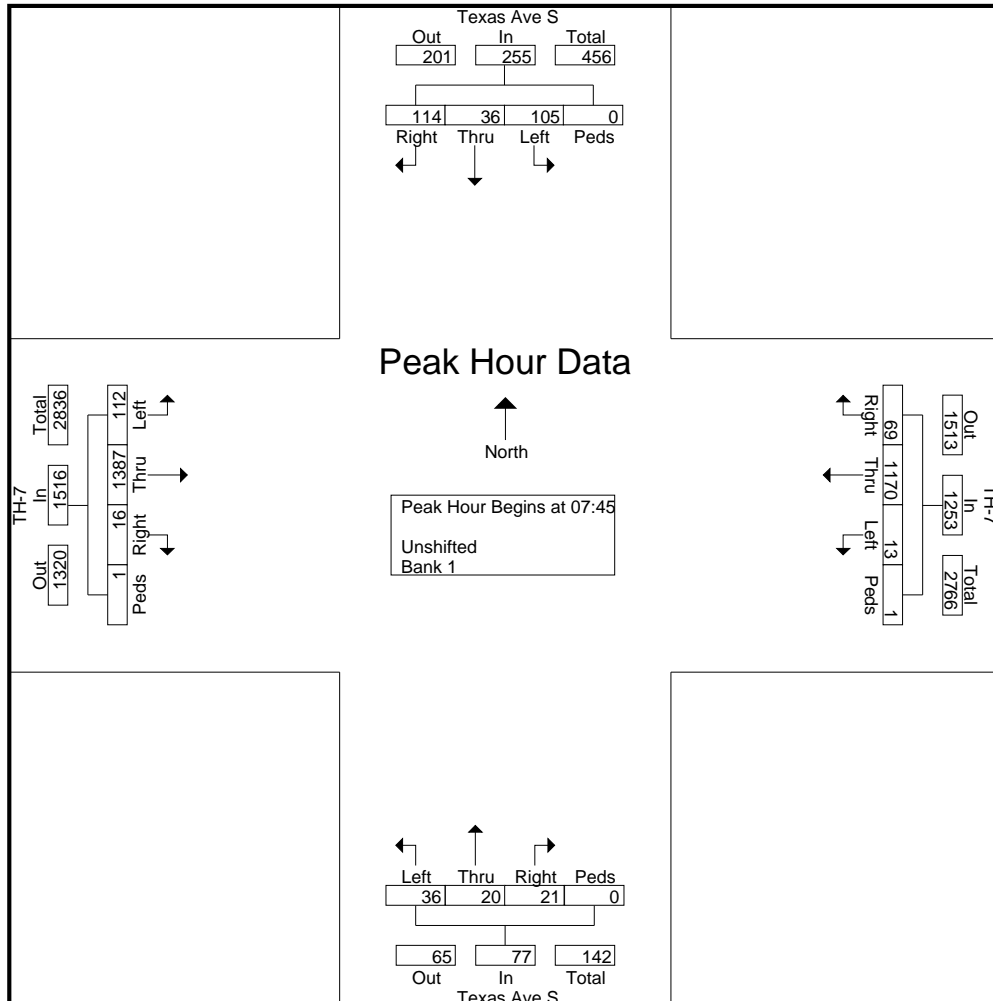

Alliant Engineering Inc Minneapolis, MN 55415

TH-7 at Texas Ave S
Ref.Pt.: 192.486
Alliant Engineering Inc
TURN MOVEMENT COUNT

File Name : 23_TH 7 at Texas Ave_011111
Site Code : 00000023
Start Date : 1/11/2011
Page No : 4

Start Time	Texas Ave S Southbound					TH-7 Westbound					Texas Ave S Northbound					TH-7 Eastbound					Int. Total
	Left	Thru	Right	Peds	App. Total	Left	Thru	Right	Peds	App. Total	Left	Thru	Right	Peds	App. Total	Left	Thru	Right	Peds	App. Total	
Peak Hour Analysis From 14:30 to 17:45 - Peak 1 of 1																					
Peak Hour for Entire Intersection Begins at 17:00																					
17:00	48	19	37	0	104	6	289	45	0	340	7	22	7	0	36	68	348	10	0	426	906
17:15	42	25	49	0	116	9	353	62	0	424	8	5	11	0	24	72	420	12	0	504	1068
17:30	45	25	55	0	125	3	315	52	0	370	7	17	11	0	35	88	419	22	1	530	1060
17:45	53	20	59	0	132	6	300	46	1	353	7	7	8	0	22	65	386	10	0	461	968
Total Volume	188	89	200	0	477	24	1257	205	1	1487	29	51	37	0	117	293	1573	54	1	1921	4002
% App. Total	39.4	18.7	41.9	0		1.6	84.5	13.8	0.1		24.8	43.6	31.6	0		15.3	81.9	2.8	0.1		
PHF	.887	.890	.847	.000	.903	.667	.890	.827	.250	.877	.906	.580	.841	.000	.813	.832	.936	.614	.250	.906	.937

