

# Alliant Engineering Inc Minneapolis, MN 55415

TH-7 at 5th Ave N / Oak Ridge Rd.

Ref.Pt.: 191.251

Alliant Engineering Inc

TURN MOVEMENT COUNT

File Name : 16\_TH 7 at 5th Ave\_011111

Site Code : 00000016

Start Date : 1/11/2011

Page No : 1

### Groups Printed- Unshifted - Bank 1

Start Time	Oak Ridge Rd. Southbound				TH-7 Westbound				5th Ave N Northbound				TH-7 Eastbound				Int. Total
	Left	Thru	Right	Peds	Left	Thru	Right	Peds	Left	Thru	Right	Peds	Left	Thru	Right	Peds	
06:00	1	4	0	1	6	32	2	0	3	4	12	0	2	88	11	0	166
06:15	6	3	4	0	23	55	1	0	8	3	14	0	1	114	15	0	247
06:30	7	17	4	0	53	86	3	0	12	7	20	0	3	168	21	2	403
06:45	11	28	8	0	29	137	3	1	10	11	21	1	2	233	35	0	530
Total	25	52	16	1	111	310	9	1	33	25	67	1	8	603	82	2	1346
07:00	2	16	4	0	17	129	0	0	11	11	21	0	1	217	38	0	467
07:15	4	9	7	0	24	133	3	0	14	16	22	1	1	361	37	0	632
07:30	9	21	6	0	21	154	5	0	19	15	42	0	4	391	40	0	727
07:45	2	27	7	0	17	199	7	0	16	16	50	0	5	386	60	0	792
Total	17	73	24	0	79	615	15	0	60	58	135	1	11	1355	175	0	2618
08:00	8	24	2	0	27	170	7	0	14	9	42	0	4	359	40	0	706
08:15	11	11	6	0	23	165	2	0	12	9	39	0	4	298	37	0	617
08:30	9	17	12	0	17	198	5	0	14	11	31	0	3	287	32	0	636
08:45	10	15	9	0	40	196	3	1	24	11	30	0	3	272	34	0	648
Total	38	67	29	0	107	729	17	1	64	40	142	0	14	1216	143	0	2607
09:00	3	13	3	0	28	158	12	0	17	13	22	0	1	203	28	0	501
09:15	5	11	0	0	30	154	5	0	13	8	29	0	5	209	16	0	485
*** BREAK ***																	
Total	8	24	3	0	58	312	17	0	30	21	51	0	6	412	44	0	986
*** BREAK ***																	
10:30	7	10	1	1	19	117	3	0	6	5	27	0	4	176	19	0	395
10:45	1	6	4	0	25	132	3	0	12	8	27	0	1	127	13	0	359
Total	8	16	5	1	44	249	6	0	18	13	54	0	5	303	32	0	754
11:00	0	11	2	0	30	132	4	0	6	9	36	0	1	160	11	0	402
11:15	5	11	6	0	28	133	6	0	10	9	32	1	1	147	6	0	395
11:30	2	11	3	0	15	176	7	0	7	9	36	0	2	175	8	0	451
11:45	5	12	5	0	31	158	11	0	11	11	34	0	6	156	8	1	449
Total	12	45	16	0	104	599	28	0	34	38	138	1	10	638	33	1	1697
12:00	1	10	2	0	32	195	8	0	10	11	48	0	1	189	18	0	525
12:15	8	6	2	0	36	150	10	0	11	7	45	0	3	174	13	0	465
12:30	5	20	1	0	33	162	8	0	8	11	34	0	2	198	12	0	494
12:45	2	15	6	0	27	168	10	0	14	12	44	0	1	165	19	0	483
Total	16	51	11	0	128	675	36	0	43	41	171	0	7	726	62	0	1967
13:00	2	7	6	0	30	173	2	0	5	6	37	0	1	196	14	0	479
13:15	7	10	3	0	33	163	4	0	15	10	29	0	1	175	12	0	462
*** BREAK ***																	
Total	9	17	9	0	63	336	6	0	20	16	66	0	2	371	26	0	941
*** BREAK ***																	
14:30	7	8	10	1	26	191	8	1	16	7	42	1	4	157	7	1	487
14:45	3	14	6	0	38	206	5	0	14	18	34	0	2	175	9	0	524
Total	10	22	16	1	64	397	13	1	30	25	76	1	6	332	16	1	1011
15:00	2	12	9	0	25	214	3	0	12	15	30	0	7	157	12	0	498
15:15	11	12	7	0	43	270	8	0	23	15	42	0	3	193	9	0	636
15:30	8	13	6	0	42	270	13	0	24	15	39	0	3	181	22	0	636
15:45	5	12	4	0	51	324	15	0	23	24	32	0	6	207	22	0	725
Total	26	49	26	0	161	1078	39	0	82	69	143	0	19	738	65	0	2495

# Alliant Engineering Inc Minneapolis, MN 55415

TH-7 at 5th Ave N / Oak Ridge Rd.  
Ref.Pt.: 191.251  
Alliant Engineering Inc  
TURN MOVEMENT COUNT

File Name : 16\_TH 7 at 5th Ave\_011111  
Site Code : 00000016  
Start Date : 1/11/2011  
Page No : 2

### Groups Printed- Unshifted - Bank 1

Start Time	Oak Ridge Rd. Southbound				TH-7 Westbound				5th Ave N Northbound				TH-7 Eastbound				Int. Total
	Left	Thru	Right	Peds	Left	Thru	Right	Peds	Left	Thru	Right	Peds	Left	Thru	Right	Peds	
16:00	2	17	5	0	43	261	7	0	31	29	44	0	3	184	12	0	638
16:15	6	17	5	0	44	295	32	3	20	28	37	0	6	221	14	0	728
16:30	6	16	6	1	36	271	17	1	33	42	39	1	7	209	15	0	700
16:45	6	9	3	0	44	340	6	0	44	40	35	0	7	259	22	0	815
Total	20	59	19	1	167	1167	62	4	128	139	155	1	23	873	63	0	2881
17:00	3	11	3	0	32	338	20	0	45	32	37	0	9	276	11	0	817
17:15	1	16	5	0	36	366	17	3	47	40	58	0	9	295	18	0	911
17:30	3	7	2	0	55	292	61	1	38	31	46	0	9	260	18	0	823
17:45	3	17	7	0	52	289	10	1	29	35	30	0	7	237	12	0	729
Total	10	51	17	0	175	1285	108	5	159	138	171	0	34	1068	59	0	3280
Grand Total	199	526	191	4	1261	7752	356	12	701	623	1369	5	145	8635	800	4	22583
Apprch %	21.6	57.2	20.8	0.4	13.4	82.6	3.8	0.1	26	23.1	50.7	0.2	1.5	90.1	8.3	0	
Total %	0.9	2.3	0.8	0	5.6	34.3	1.6	0.1	3.1	2.8	6.1	0	0.6	38.2	3.5	0	
Unshifted	194	511	184	4	1228	7578	347	12	680	606	1340	5	140	8479	785	4	22097
% Unshifted	97.5	97.1	96.3	100	97.4	97.8	97.5	100	97	97.3	97.9	100	96.6	98.2	98.1	100	97.8
Bank 1	5	15	7	0	33	174	9	0	21	17	29	0	5	156	15	0	486
% Bank 1	2.5	2.9	3.7	0	2.6	2.2	2.5	0	3	2.7	2.1	0	3.4	1.8	1.9	0	2.2

# Alliant Engineering Inc Minneapolis, MN 55415

TH-7 at 5th Ave N / Oak Ridge Rd.  
Ref.Pt.: 191.251  
Alliant Engineering Inc  
TURN MOVEMENT COUNT

File Name : 16\_TH 7 at 5th Ave\_011111  
Site Code : 00000016  
Start Date : 1/11/2011  
Page No : 3

Start Time	Oak Ridge Rd. Southbound					TH-7 Westbound					5th Ave N Northbound					TH-7 Eastbound					Int. Total
	Left	Thru	Right	Peds	App. Total	Left	Thru	Right	Peds	App. Total	Left	Thru	Right	Peds	App. Total	Left	Thru	Right	Peds	App. Total	
Peak Hour Analysis From 06:00 to 10:00 - Peak 1 of 1																					
Peak Hour for Entire Intersection Begins at 07:15																					
07:15	4	9	7	0	20	24	133	3	0	160	14	16	22	1	53	1	361	37	0	399	632
07:30	9	21	6	0	36	21	154	5	0	180	19	15	42	0	76	4	391	40	0	435	727
07:45	2	27	7	0	36	17	199	7	0	223	16	16	50	0	82	5	386	60	0	451	792
08:00	8	24	2	0	34	27	170	7	0	204	14	9	42	0	65	4	359	40	0	403	706
Total Volume	23	81	22	0	126	89	656	22	0	767	63	56	156	1	276	14	1497	177	0	1688	2857
% App. Total	18.3	64.3	17.5	0		11.6	85.5	2.9	0		22.8	20.3	56.5	0.4		0.8	88.7	10.5	0		
PHF	.639	.750	.786	.000	.875	.824	.824	.786	.000	.860	.829	.875	.780	.250	.841	.700	.957	.738	.000	.936	.902

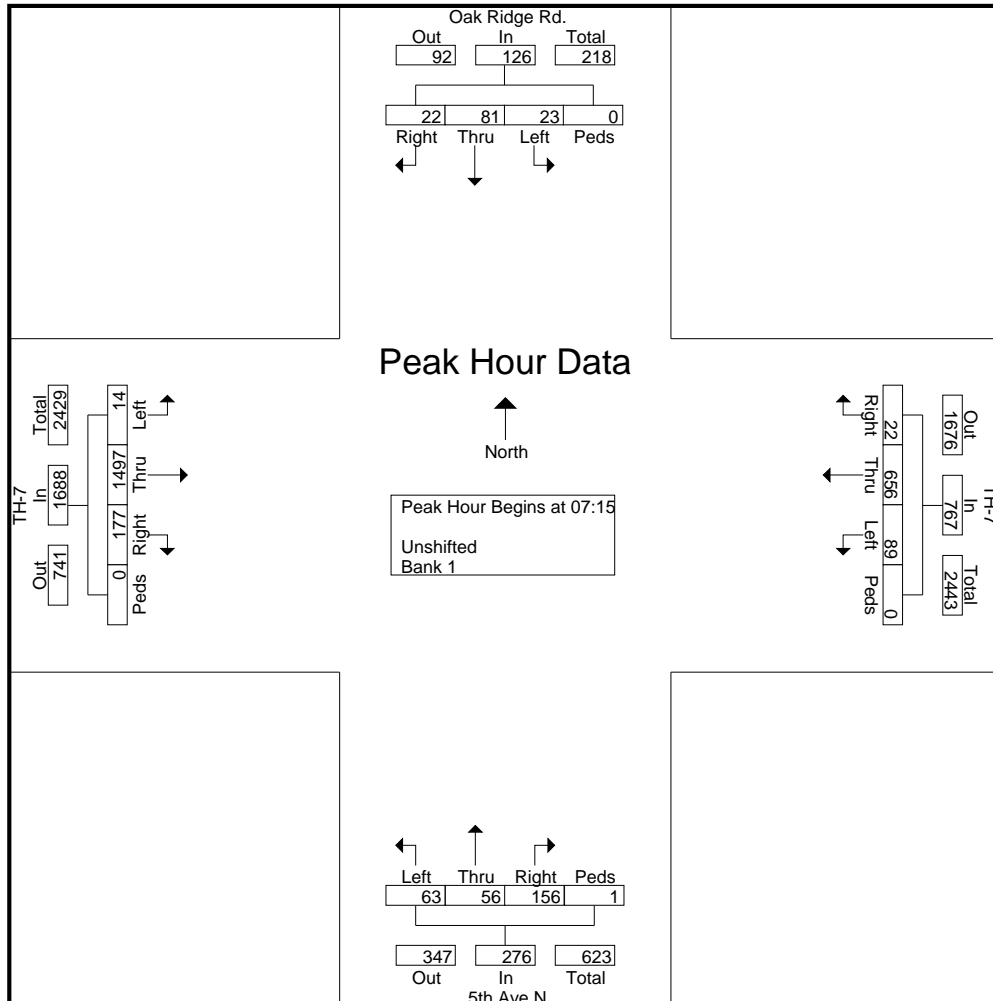

# Alliant Engineering Inc Minneapolis, MN 55415

TH-7 at 5th Ave N / Oak Ridge Rd.  
Ref.Pt.: 191.251  
Alliant Engineering Inc  
TURN MOVEMENT COUNT

File Name : 16\_TH 7 at 5th Ave\_011111  
Site Code : 00000016  
Start Date : 1/11/2011  
Page No : 4

Start Time	Oak Ridge Rd. Southbound					TH-7 Westbound					5th Ave N Northbound					TH-7 Eastbound					Int. Total
	Left	Thru	Right	Peds	App. Total	Left	Thru	Right	Peds	App. Total	Left	Thru	Right	Peds	App. Total	Left	Thru	Right	Peds	App. Total	
Peak Hour Analysis From 14:30 to 17:45 - Peak 1 of 1																					
Peak Hour for Entire Intersection Begins at 16:45																					
16:45	6	9	3	0	18	44	340	6	0	390	44	40	35	0	119	7	259	22	0	288	815
17:00	3	11	3	0	17	32	338	20	0	390	45	32	37	0	114	9	276	11	0	296	817
17:15	1	16	5	0	22	36	366	17	3	422	47	40	58	0	145	9	295	18	0	322	911
17:30	3	7	2	0	12	55	292	61	1	409	38	31	46	0	115	9	260	18	0	287	823
Total Volume	13	43	13	0	69	167	1336	104	4	1611	174	143	176	0	493	34	1090	69	0	1193	3366
% App. Total	18.8	62.3	18.8	0		10.4	82.9	6.5	0.2		35.3	29	35.7	0		2.8	91.4	5.8	0		
PHF	.542	.672	.650	.000	.784	.759	.913	.426	.333	.954	.926	.894	.759	.000	.850	.944	.924	.784	.000	.926	.924

