



# MINNESOTA DEPT OF TRANSPORTATION

## TRAFFIC DATA COLLECTION - METRO

TH-7 at Hopkins Cross Rd / 17th Ave N  
 ref.pt. 190.485  
 Counter: Ken Levin ALLIANT CONSULT.  
 TURN MOVEMENT COUNT

File Name : TH-7 at Hopkins Cross Rd - 17th Ave N 2007  
 Site Code : 00000148  
 Start Date : 11/29/2007  
 Page No : 1

### Groups Printed- Cars & Trucks

Start Time	Hopkins Cross Rd / CSAH-73 Southbound				TH-7 Westbound				17th Ave N. Northbound				TH-7 Eastbound				Int. Total
	Left	Thru	Right	Peds	Left	Thru	Right	Peds	Left	Thru	Right	Peds	Left	Thru	Right	Peds	
06:00	4	5	2	0	2	29	1	0	2	7	0	0	14	61	1	0	128
06:15	7	3	7	0	2	45	6	0	3	3	0	0	20	107	5	0	208
06:30	13	8	15	0	5	53	10	0	4	8	2	0	24	152	2	0	296
06:45	22	19	23	0	3	93	14	0	11	10	2	0	25	196	1	0	419
Total	46	35	47	0	12	220	31	0	20	28	4	0	83	516	9	0	1051
07:00	23	10	22	0	3	79	11	0	10	18	0	0	51	234	2	0	463
07:15	23	16	34	0	11	117	18	0	11	30	8	0	42	287	13	0	610
07:30	35	21	34	0	11	122	21	0	19	39	17	0	90	306	8	0	723
07:45	43	41	50	0	10	216	22	0	15	36	4	0	56	296	8	0	797
Total	124	88	140	0	35	534	72	0	55	123	29	0	239	1123	31	0	2593
08:00	36	32	32	0	12	138	22	0	13	27	2	0	45	294	7	0	660
08:15	38	26	38	0	5	108	16	0	10	23	7	0	30	260	5	0	566
08:30	27	20	24	0	8	142	28	0	6	13	9	0	32	222	6	0	537
08:45	30	31	29	2	8	155	22	0	9	23	11	0	39	230	5	0	594
Total	131	109	123	2	33	543	88	0	38	86	29	0	146	1006	23	0	2357
09:00	37	20	23	0	9	118	27	0	6	15	5	0	60	170	2	0	492
09:15	32	35	18	0	3	80	26	0	7	22	4	0	46	141	10	0	424
*** BREAK ***																	
Total	69	55	41	0	12	198	53	0	13	37	9	0	106	311	12	0	916
*** BREAK ***																	
10:30	37	35	15	0	5	94	16	0	6	25	4	0	28	121	8	0	394
10:45	31	21	23	0	5	99	27	0	3	14	6	0	47	120	5	0	401
Total	68	56	38	0	10	193	43	0	9	39	10	0	75	241	13	0	795
11:00	33	34	30	0	1	108	29	0	12	24	5	0	43	114	10	0	443
11:15	33	30	16	0	7	116	35	0	11	28	3	0	42	123	4	0	448
11:30	40	30	20	0	7	129	35	0	14	29	5	0	46	143	5	0	503
11:45	36	29	19	0	9	115	34	0	4	24	3	0	37	128	4	0	442
Total	142	123	85	0	24	468	133	0	41	105	16	0	168	508	23	0	1836
12:00	31	30	26	0	12	152	34	0	19	19	4	0	39	123	10	0	499
12:15	30	32	22	0	15	109	43	0	14	39	8	0	42	116	8	0	478
12:30	54	45	23	0	9	121	34	0	16	30	7	0	38	158	8	0	543
12:45	51	32	21	0	11	136	20	0	8	30	8	0	40	118	7	0	482
Total	166	139	92	0	47	518	131	0	57	118	27	0	159	515	33	0	2002
13:00	33	38	25	0	11	144	20	0	11	34	3	0	40	126	6	0	491
13:15	39	20	22	0	16	145	31	0	9	25	5	0	34	127	5	0	478
*** BREAK ***																	
Total	72	58	47	0	27	289	51	0	20	59	8	0	74	253	11	0	969
*** BREAK ***																	
14:30	52	31	28	0	6	170	43	0	10	35	5	0	34	121	2	0	537
14:45	33	52	53	0	12	221	38	0	16	23	3	0	39	158	11	0	659
Total	85	83	81	0	18	391	81	0	26	58	8	0	73	279	13	0	1196
15:00	34	33	36	0	10	166	35	0	18	32	8	0	36	118	9	0	535
15:15	36	25	37	0	6	193	31	0	10	32	11	0	44	135	4	0	564
15:30	33	27	46	0	14	229	51	0	18	50	6	0	53	157	5	0	689
15:45	43	39	50	0	11	235	59	0	25	40	4	0	40	157	12	0	715
Total	146	124	169	0	41	823	176	0	71	154	29	0	173	567	30	0	2503



# MINNESOTA DEPT OF TRANSPORTATION

## TRAFFIC DATA COLLECTION - METRO

TH-7 at Hopkins Cross Rd / 17th Ave N  
 ref.pt. 190.485  
 Counter: Ken Levin ALLIANT CONSULT.  
 TURN MOVEMENT COUNT

File Name : TH-7 at Hopkins Cross Rd - 17th Ave N 2007  
 Site Code : 00000148  
 Start Date : 11/29/2007  
 Page No : 2

### Groups Printed- Cars & Trucks

Start Time	Hopkins Cross Rd / CSAH-73 Southbound				TH-7 Westbound				17th Ave N. Northbound				TH-7 Eastbound				Int. Total
	Left	Thru	Right	Peds	Left	Thru	Right	Peds	Left	Thru	Right	Peds	Left	Thru	Right	Peds	
16:00	43	32	40	0	12	239	60	0	18	52	11	0	57	136	11	0	711
16:15	37	47	34	0	20	250	60	0	20	62	13	0	52	156	9	0	760
16:30	34	35	41	0	12	272	50	0	24	65	15	0	54	159	6	0	767
16:45	36	41	47	0	8	282	61	0	21	61	14	0	59	171	14	1	816
Total	150	155	162	0	52	1043	231	0	83	240	53	0	222	622	40	1	3054
17:00	52	31	51	7	14	250	63	0	24	57	13	0	51	203	10	0	826
17:15	51	46	51	0	9	321	62	0	24	76	15	0	68	247	11	0	981
17:30	36	45	37	1	14	269	67	0	29	61	10	0	56	193	9	0	827
17:45	42	46	42	0	15	275	65	0	16	36	7	0	45	182	6	0	777
Total	181	168	181	8	52	1115	257	0	93	230	45	0	220	825	36	0	3411
Grand Total	1380	1193	1206	10	363	6335	1347	0	526	1277	267	0	1738	6766	274	1	22683
Apprch %	36.4	31.5	31.8	0.3	4.5	78.7	16.7	0	25.4	61.7	12.9	0	19.8	77.1	3.1	0	
Total %	6.1	5.3	5.3	0	1.6	27.9	5.9	0	2.3	5.6	1.2	0	7.7	29.8	1.2	0	



# MINNESOTA DEPT OF TRANSPORTATION

## TRAFFIC DATA COLLECTION - METRO

TH-7 at Hopkins Cross Rd / 17th Ave N  
 ref.pt. 190.485  
 Counter: Ken Levin ALLIANT CONSULT.  
 TURN MOVEMENT COUNT

File Name : TH-7 at Hopkins Cross Rd - 17th Ave N 2007  
 Site Code : 00000148  
 Start Date : 11/29/2007  
 Page No : 3

Start Time	Hopkins Cross Rd / CSAH-73 Southbound					TH-7 Westbound					17th Ave N. Northbound					TH-7 Eastbound					Int. Total
	Left	Thru	Right	Peds	App. Total	Left	Thru	Right	Peds	App. Total	Left	Thru	Right	Peds	App. Total	Left	Thru	Right	Peds	App. Total	
Peak Hour Analysis From 06:00 to 09:15 - Peak 1 of 1																					
Peak Hour for Entire Intersection Begins at 07:15																					
07:15	23	16	34	0	73	11	117	18	0	146	11	30	8	0	49	42	287	13	0	342	610
07:30	35	21	34	0	90	11	122	21	0	154	19	39	17	0	75	90	306	8	0	404	723
07:45	43	41	50	0	134	10	216	22	0	248	15	36	4	0	55	56	296	8	0	360	797
08:00	36	32	32	0	100	12	138	22	0	172	13	27	2	0	42	45	294	7	0	346	660
Total Volume	137	110	150	0	397	44	593	83	0	720	58	132	31	0	221	233	1183	36	0	1452	2790
% App. Total	34.5	27.7	37.8	0		6.1	82.4	11.5	0		26.2	59.7	14	0		16	81.5	2.5	0		
PHF	.797	.671	.750	.000	.741	.917	.686	.943	.000	.726	.763	.846	.456	.000	.737	.647	.967	.692	.000	.899	.875

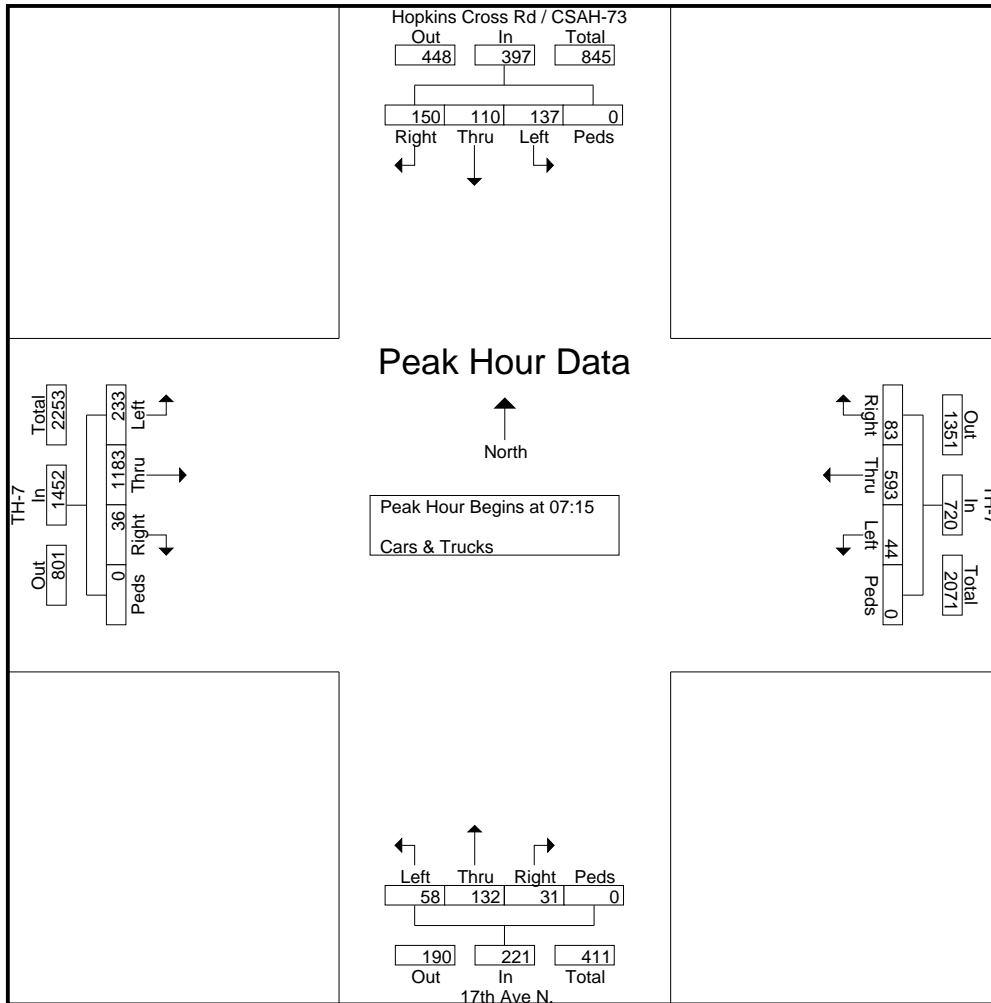



# MINNESOTA DEPT OF TRANSPORTATION

## TRAFFIC DATA COLLECTION - METRO

TH-7 at Hopkins Cross Rd / 17th Ave N  
 ref.pt. 190.485  
 Counter: Ken Levin ALLIANT CONSULT.  
 TURN MOVEMENT COUNT

File Name : TH-7 at Hopkins Cross Rd - 17th Ave N 2007  
 Site Code : 00000148  
 Start Date : 11/29/2007  
 Page No : 4

Start Time	Hopkins Cross Rd / CSAH-73 Southbound					TH-7 Westbound					17th Ave N. Northbound					TH-7 Eastbound					Int. Total
	Left	Thru	Right	Peds	App. Total	Left	Thru	Right	Peds	App. Total	Left	Thru	Right	Peds	App. Total	Left	Thru	Right	Peds	App. Total	
Peak Hour Analysis From 14:30 to 17:45 - Peak 1 of 1																					
Peak Hour for Entire Intersection Begins at 16:45																					
16:45	36	41	47	0	124	8	282	61	0	351	21	61	14	0	96	59	171	14	1	245	816
17:00	52	31	51	7	141	14	250	63	0	327	24	57	13	0	94	51	203	10	0	264	826
17:15	51	46	51	0	148	9	321	62	0	392	24	76	15	0	115	68	247	11	0	326	981
17:30	36	45	37	1	119	14	269	67	0	350	29	61	10	0	100	56	193	9	0	258	827
Total Volume	175	163	186	8	532	45	1122	253	0	1420	98	255	52	0	405	234	814	44	1	1093	3450
% App. Total	32.9	30.6	35	1.5		3.2	79	17.8	0		24.2	63	12.8	0		21.4	74.5	4	0.1		
PHF	.841	.886	.912	.286	.899	.804	.874	.944	.000	.906	.845	.839	.867	.000	.880	.860	.824	.786	.250	.838	.879

