



MINNESOTA DEPT OF TRANSPORTATION

TRAFFIC DATA COLLECTION - METRO

TH-7 at CSAH-101
 ref.pt.: 186.196
 Counter: Ken Levin - ALLIANT CONSULT.
 TURN MOVEMENT COUNT

File Name : TH-7 at CSAH-101 2007
 Site Code : 00000153
 Start Date : 12/5/2007
 Page No : 1

Groups Printed- Cars & Trucks

Start Time	CSAH-101 Southbound				TH-7 Westbound				CSAH-101 Northbound				TH-7 Eastbound				Int. Total	
	Left	Thru	Right	Peds	Left	Thru	Right	Peds	Left	Thru	Right	Peds	Left	Thru	Right	Peds		
06:00	14	8	7	0	0	0	0	0	0	0	0	0	19	203	2	0	253	
06:15	14	11	3	0	17	69	3	0	2	14	15	0	13	279	15	0	455	
06:30	7	25	11	0	21	113	6	0	10	24	17	0	25	373	20	0	652	
06:45	22	31	24	0	39	134	5	0	8	35	23	0	14	372	25	0	732	
Total	57	75	45	0	77	316	14	0	20	73	55	0	71	1227	62	0	2092	
07:00	20	47	15	1	44	129	7	0	8	36	25	0	30	420	33	1	816	
07:15	23	55	22	0	50	141	16	0	15	71	24	0	37	395	33	0	882	
07:30	26	87	15	0	47	130	14	0	16	84	18	0	48	395	33	0	913	
07:45	27	114	21	0	68	136	14	0	9	72	21	0	37	367	35	0	921	
Total	96	303	73	1	209	536	51	0	48	263	88	0	152	1577	134	1	3532	
08:00	27	50	14	1	44	125	10	0	16	79	33	0	52	365	23	0	839	
08:15	21	47	19	0	40	121	11	0	17	65	15	0	61	391	33	0	841	
08:30	32	54	29	0	36	108	16	0	20	77	22	0	58	357	31	0	840	
08:45	28	50	18	0	30	131	26	0	33	73	18	0	72	351	22	0	852	
Total	108	201	80	1	150	485	63	0	86	294	88	0	243	1464	109	0	3372	
09:00	30	49	29	1	34	107	30	0	32	69	19	0	46	249	17	0	712	
09:15	28	44	21	0	29	155	27	0	30	62	32	0	60	267	6	0	761	
09:30	0	0	0	0	32	121	25	0	34	61	25	0	0	0	0	0	298	
*** BREAK ***																		
Total	58	93	50	1	95	383	82	0	96	192	76	0	106	516	23	0	1771	
*** BREAK ***																		
10:30	38	36	28	0	29	146	36	0	29	60	19	0	56	243	18	0	738	
10:45	42	66	24	0	44	171	29	0	26	43	19	0	51	173	22	0	710	
Total	80	102	52	0	73	317	65	0	55	103	38	0	107	416	40	0	1448	
11:00	47	55	29	0	36	138	46	0	22	59	17	0	47	221	14	0	731	
11:15	61	73	29	0	34	127	34	0	37	65	11	0	49	197	10	0	727	
11:30	46	58	28	0	35	145	32	0	31	68	11	0	58	195	19	0	726	
11:45	44	74	26	0	51	129	38	0	26	66	18	0	66	185	20	0	743	
Total	198	260	112	0	156	539	150	0	116	258	57	0	220	798	63	0	2927	
12:00	54	74	36	0	28	137	38	0	36	70	24	0	62	180	22	0	761	
12:15	61	64	38	0	45	142	41	0	41	104	17	0	62	157	15	0	787	
12:30	53	98	36	0	49	148	38	0	45	70	22	0	56	168	21	0	804	
12:45	60	88	34	0	50	162	36	0	38	72	13	0	56	194	20	0	823	
Total	228	324	144	0	172	589	153	0	160	316	76	0	236	699	78	0	3175	
13:00	52	75	23	0	36	151	44	0	37	74	25	0	49	177	23	0	766	
13:15	63	56	41	0	36	186	40	0	32	85	22	0	60	153	9	0	783	
*** BREAK ***																		
Total	115	131	64	0	72	337	84	0	69	159	47	0	109	330	32	0	1549	
*** BREAK ***																		
14:30	40	115	55	0	50	189	20	0	28	63	33	0	43	182	11	0	829	
14:45	48	104	57	0	54	211	29	0	50	82	54	0	64	164	16	0	933	
Total	88	219	112	0	104	400	49	0	78	145	87	0	107	346	27	0	1762	
15:00	51	83	53	0	41	178	45	0	58	88	59	2	59	191	17	0	925	
15:15	54	83	53	0	50	249	24	0	48	79	52	0	65	223	32	0	1012	
15:30	45	75	65	0	51	243	26	0	58	77	44	0	47	223	22	0	976	
15:45	49	106	71	0	48	283	31	1	62	78	35	0	62	258	19	0	1103	
Total	199	347	242	0	190	953	126	1	226	322	190	2	233	895	90	0	4016	



MINNESOTA DEPT OF TRANSPORTATION

TRAFFIC DATA COLLECTION - METRO

TH-7 at CSAH-101
 ref.pt.: 186.196
 Counter: Ken Levin - ALLIANT CONSULT.
 TURN MOVEMENT COUNT

File Name : TH-7 at CSAH-101 2007
 Site Code : 00000153
 Start Date : 12/5/2007
 Page No : 2

Groups Printed- Cars & Trucks

Start Time	CSAH-101 Southbound				TH-7 Westbound				CSAH-101 Northbound				TH-7 Eastbound				Int. Total
	Left	Thru	Right	Peds	Left	Thru	Right	Peds	Left	Thru	Right	Peds	Left	Thru	Right	Peds	
16:00	46	94	69	0	50	293	33	0	45	55	48	0	77	224	21	0	1055
16:15	56	110	62	0	57	295	36	0	57	105	27	0	54	229	14	0	1102
16:30	41	110	62	0	57	367	20	0	56	87	33	0	49	215	18	0	1115
16:45	49	101	65	0	62	337	30	0	70	106	60	0	58	203	13	0	1154
Total	192	415	258	0	226	1292	119	0	228	353	168	0	238	871	66	0	4426
17:00	49	105	69	0	61	335	31	0	67	100	58	0	55	201	7	0	1138
17:15	51	112	69	0	50	335	20	0	71	79	49	0	52	236	9	0	1133
17:30	50	122	74	0	60	352	17	0	81	95	41	0	47	210	3	0	1152
17:45	46	105	53	0	71	328	25	0	78	85	34	0	61	147	7	0	1040
Total	196	444	265	0	242	1350	93	0	297	359	182	0	215	794	26	0	4463
Grand Total	1615	2914	1497	3	1766	7497	1049	1	1479	2837	1152	2	2037	9933	750	1	34533
Apprch %	26.8	48.3	24.8	0	17.1	72.7	10.2	0	27	51.9	21.1	0	16	78.1	5.9	0	
Total %	4.7	8.4	4.3	0	5.1	21.7	3	0	4.3	8.2	3.3	0	5.9	28.8	2.2	0	



MINNESOTA DEPT OF TRANSPORTATION

TRAFFIC DATA COLLECTION - METRO

TH-7 at CSAH-101
 ref.pt.: 186.196
 Counter: Ken Levin - ALLIANT CONSULT.
 TURN MOVEMENT COUNT

File Name : TH-7 at CSAH-101 2007
 Site Code : 00000153
 Start Date : 12/5/2007
 Page No : 3

Start Time	CSAH-101 Southbound					TH-7 Westbound					CSAH-101 Northbound					TH-7 Eastbound					Int. Total
	Left	Thru	Right	Peds	App. Total	Left	Thru	Right	Peds	App. Total	Left	Thru	Right	Peds	App. Total	Left	Thru	Right	Peds	App. Total	
Peak Hour Analysis From 06:00 to 09:15 - Peak 1 of 1																					
Peak Hour for Entire Intersection Begins at 07:15																					
07:15	23	55	22	0	100	50	141	16	0	207	15	71	24	0	110	37	395	33	0	465	882
07:30	26	87	15	0	128	47	130	14	0	191	16	84	18	0	118	48	395	33	0	476	913
07:45	27	114	21	0	162	68	136	14	0	218	9	72	21	0	102	37	367	35	0	439	921
08:00	27	50	14	1	92	44	125	10	0	179	16	79	33	0	128	52	365	23	0	440	839
Total Volume	103	306	72	1	482	209	532	54	0	795	56	306	96	0	458	174	1522	124	0	1820	3555
% App. Total	21.4	63.5	14.9	0.2		26.3	66.9	6.8	0		12.2	66.8	21	0		9.6	83.6	6.8	0		
PHF	.954	.671	.818	.250	.744	.768	.943	.844	.000	.912	.875	.911	.727	.000	.895	.837	.963	.886	.000	.956	.965

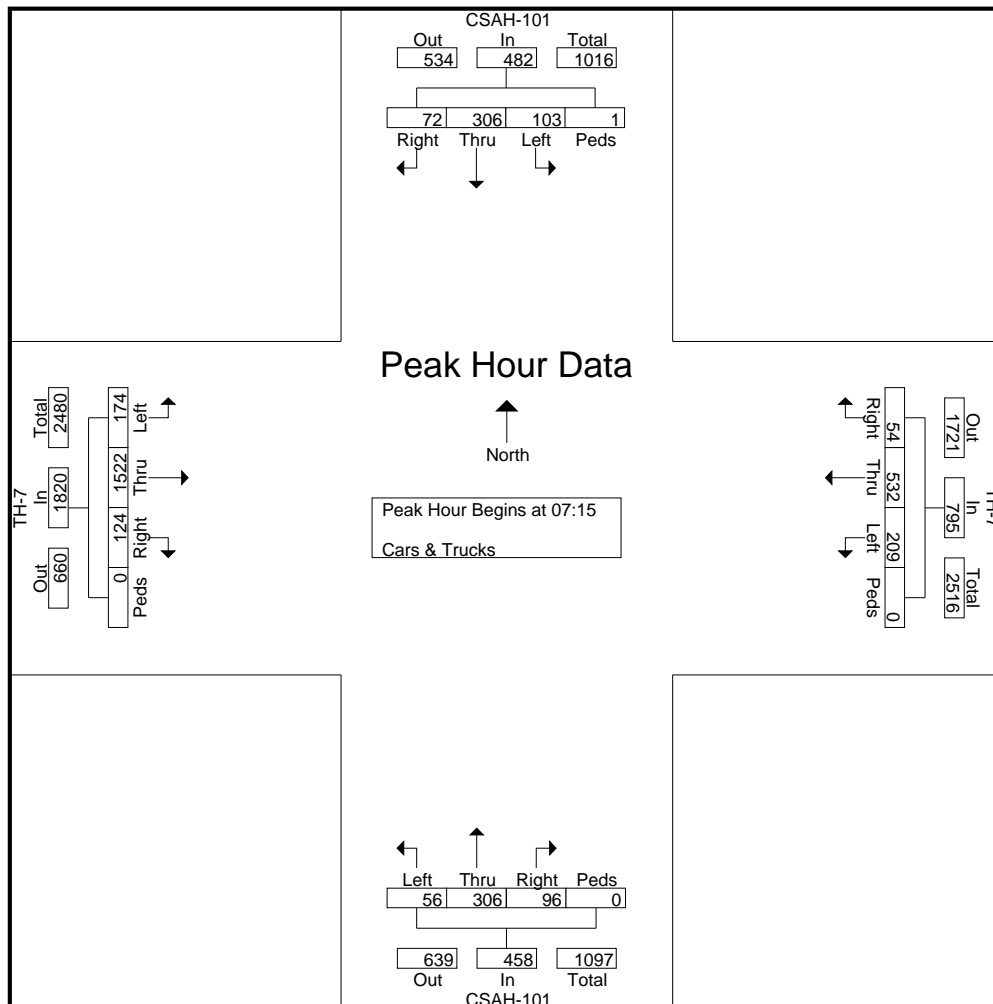



MINNESOTA DEPT OF TRANSPORTATION

TRAFFIC DATA COLLECTION - METRO

TH-7 at CSAH-101
 ref.pt.: 186.196
 Counter: Ken Levin - ALLIANT CONSULT.
 TURN MOVEMENT COUNT

File Name : TH-7 at CSAH-101 2007
 Site Code : 00000153
 Start Date : 12/5/2007
 Page No : 4

Start Time	CSAH-101 Southbound					TH-7 Westbound					CSAH-101 Northbound					TH-7 Eastbound					Int. Total
	Left	Thru	Right	Peds	App. Total	Left	Thru	Right	Peds	App. Total	Left	Thru	Right	Peds	App. Total	Left	Thru	Right	Peds	App. Total	
Peak Hour Analysis From 14:30 to 17:45 - Peak 1 of 1																					
Peak Hour for Entire Intersection Begins at 16:45																					
16:45	49	101	65	0	215	62	337	30	0	429	70	106	60	0	236	58	203	13	0	274	1154
17:00	49	105	69	0	223	61	335	31	0	427	67	100	58	0	225	55	201	7	0	263	1138
17:15	51	112	69	0	232	50	335	20	0	405	71	79	49	0	199	52	236	9	0	297	1133
17:30	50	122	74	0	246	60	352	17	0	429	81	95	41	0	217	47	210	3	0	260	1152
Total Volume	199	440	277	0	916	233	1359	98	0	1690	289	380	208	0	877	212	850	32	0	1094	4577
% App. Total	21.7	48	30.2	0		13.8	80.4	5.8	0		33	43.3	23.7	0		19.4	77.7	2.9	0		
PHF	.975	.902	.936	.000	.931	.940	.965	.790	.000	.985	.892	.896	.867	.000	.929	.914	.900	.615	.000	.921	.992

