

# MN Dept of Transportation

TRAFFIC DATA COLLECTION - Metro

TH-65 at 187th Lane NE  
 Ref.Pt.: 023.164  
 video CL  
 TURN MOVEMENT COUNT

File Name : TH-65 at 187th Lane NE 2015  
 Site Code : CL  
 Start Date : 2/5/2015  
 Page No : 1

Groups Printed- Cars +

Start Time	TH-65 Southbound				187th Lane NE Westbound				TH-65 Northbound				187th Lane NE Eastbound				Int. Total
	Left	Thru	Right	Peds	Left	Thru	Right	Peds	Left	Thru	Right	Peds	Left	Thru	Right	Peds	
06:00	0	392	8	0	0	0	0	0	5	43	0	0	3	0	16	0	467
06:15	1	499	28	0	0	0	0	0	7	63	0	0	1	0	11	0	610
06:30	0	444	22	0	0	0	0	0	6	88	0	0	2	0	18	0	580
06:45	0	444	46	0	1	0	0	0	9	89	0	0	1	0	16	0	606
Total	1	1779	104	0	1	0	0	0	27	283	0	0	7	0	61	0	2263
07:00	1	406	17	0	0	0	0	0	4	94	0	0	3	0	21	0	546
07:15	4	421	18	0	1	1	0	0	1	106	0	0	3	1	7	0	563
07:30	3	377	17	0	0	0	0	0	3	131	1	0	1	0	14	0	547
07:45	8	335	21	0	0	0	0	0	8	125	1	0	3	0	12	0	513
Total	16	1539	73	0	1	1	0	0	16	456	2	0	10	1	54	0	2169
08:00	2	277	12	0	0	0	0	0	4	91	0	0	3	2	12	0	403
08:15	8	279	26	0	1	2	0	0	8	80	0	0	6	0	7	0	417
08:30	3	245	10	0	0	0	0	0	11	92	1	0	6	0	10	0	378
08:45	7	210	18	0	1	1	0	0	8	64	0	0	2	2	13	0	326
Total	20	1011	66	0	2	3	0	0	31	327	1	0	17	4	42	0	1524
09:00	3	259	11	0	0	2	1	0	4	93	0	0	4	2	11	0	390
09:15	3	194	11	0	0	1	0	0	4	93	0	0	1	2	7	0	316
09:30	1	170	7	0	2	3	0	0	5	101	0	0	5	4	6	0	304
09:45	4	150	10	0	1	0	0	0	8	91	1	0	4	1	11	0	281
Total	11	773	39	0	3	6	1	0	21	378	1	0	14	9	35	0	1291
10:00	3	154	10	0	1	1	0	0	3	112	1	0	6	1	10	0	302
10:15	3	176	8	0	2	1	0	0	6	101	2	0	4	0	9	0	312
10:30	4	118	10	0	2	3	0	0	10	105	1	0	5	2	15	0	275
10:45	3	122	6	0	1	0	0	0	6	115	3	0	2	2	8	0	268
Total	13	570	34	0	6	5	0	0	25	433	7	0	17	5	42	0	1157
11:00	1	134	12	0	3	0	0	0	6	106	3	0	5	2	8	0	280
11:15	2	178	14	0	4	4	0	0	4	135	1	0	1	2	8	0	353
11:30	4	149	7	0	1	0	0	0	5	129	0	0	6	2	8	0	311
11:45	5	119	7	0	1	1	0	0	17	115	0	0	8	1	7	0	281
Total	12	580	40	0	9	5	0	0	32	485	4	0	20	7	31	0	1225
12:00	1	145	12	0	5	4	1	0	12	133	1	0	5	3	8	0	330
12:15	3	147	8	0	2	1	0	0	5	147	0	0	10	1	11	0	335
12:30	5	142	11	0	2	1	0	0	10	148	1	0	6	3	14	0	343
12:45	3	142	10	0	2	2	0	0	13	143	7	0	7	2	11	0	342
Total	12	576	41	0	11	8	1	0	40	571	9	0	28	9	44	0	1350
13:00	4	146	11	0	2	0	0	0	8	144	1	0	3	1	7	0	327
13:15	4	118	10	0	0	0	0	0	10	156	2	0	4	0	14	0	318
13:30	6	145	10	0	1	3	1	0	10	181	0	0	9	2	8	0	376
13:45	1	146	4	0	1	2	1	0	7	180	0	0	4	0	12	0	358
Total	15	555	35	0	4	5	2	0	35	661	3	0	20	3	41	0	1379
14:00	3	129	9	0	1	0	1	0	9	192	6	0	8	3	12	0	373
14:15	5	128	12	0	3	0	0	0	2	208	2	0	4	1	16	0	381
14:30	4	136	11	0	3	1	2	0	10	278	1	0	4	2	10	0	462
14:45	4	133	6	0	1	2	0	0	10	271	3	0	3	1	8	0	442
Total	16	526	38	0	8	3	3	0	31	949	12	0	19	7	46	0	1658
15:00	5	132	4	0	5	0	0	0	9	285	1	0	13	2	6	0	462
15:15	3	156	9	0	4	2	1	0	9	319	3	0	13	2	8	0	529
15:30	1	131	19	0	5	3	1	0	6	407	0	0	18	2	20	0	613
15:45	7	179	14	0	1	0	0	0	14	420	1	0	19	2	16	0	673
Total	16	598	46	0	15	5	2	0	38	1431	5	0	63	8	50	0	2277

# MN Dept of Transportation

TRAFFIC DATA COLLECTION - Metro

TH-65 at 187th Lane NE  
 Ref.Pt.: 023.164  
 video CL  
 TURN MOVEMENT COUNT

File Name : TH-65 at 187th Lane NE 2015  
 Site Code : CL  
 Start Date : 2/5/2015  
 Page No : 2

Groups Printed- Cars +

Start Time	TH-65 Southbound				187th Lane NE Westbound				TH-65 Northbound				187th Lane NE Eastbound				Int. Total
	Left	Thru	Right	Peds	Left	Thru	Right	Peds	Left	Thru	Right	Peds	Left	Thru	Right	Peds	
16:00	8	135	7	0	2	1	0	0	9	474	1	0	22	4	13	0	676
16:15	10	186	10	0	0	1	1	0	8	479	2	0	18	3	6	0	724
16:30	4	154	10	0	6	1	0	0	10	472	3	0	27	4	12	0	703
16:45	4	195	12	0	0	0	0	0	7	518	1	0	14	3	15	0	769
Total	26	670	39	0	8	3	1	0	34	1943	7	0	81	14	46	0	2872
17:00	2	157	6	0	2	0	0	0	14	481	2	0	19	0	22	0	705
17:15	2	176	10	0	1	1	0	0	8	480	0	0	8	2	10	0	698
17:30	4	159	8	0	2	0	0	0	2	436	1	0	21	1	14	0	648
17:45	11	167	10	0	0	1	0	0	4	399	0	0	7	3	7	0	609
Total	19	659	34	0	5	2	0	0	28	1796	3	0	55	6	53	0	2660
18:00	9	170	4	0	3	0	2	0	8	329	2	0	7	2	10	0	546
18:15	7	154	4	0	5	1	1	0	4	345	1	0	15	1	7	0	545
18:30	6	129	4	0	2	0	3	0	1	294	0	0	2	0	6	0	447
18:45	5	129	19	0	1	1	2	0	10	264	1	0	7	0	8	0	447
Total	27	582	31	0	11	2	8	0	23	1232	4	0	31	3	31	0	1985

\*\*\*\*BREAK\*\*\*\*

Grand Total	204	10418	620	0	84	48	18	0	381	10945	58	0	382	76	576	0	23810
Apprch %	1.8	92.7	5.5	0	56	32	12	0	3.3	96.1	0.5	0	36.9	7.4	55.7	0	
Total %	0.9	43.8	2.6	0	0.4	0.2	0.1	0	1.6	46	0.2	0	1.6	0.3	2.4	0	

# MN Dept of Transportation

TRAFFIC DATA COLLECTION - Metro

TH-65 at 187th Lane NE  
 Ref.Pt.: 023.164  
 video CL  
 TURN MOVEMENT COUNT

File Name : TH-65 at 187th Lane NE 2015  
 Site Code : CL  
 Start Date : 2/5/2015  
 Page No : 3

Start Time	TH-65 Southbound					187th Lane NE Westbound					TH-65 Northbound					187th Lane NE Eastbound					Int. Total
	Left	Thru	Right	Peds	App. Total	Left	Thru	Right	Peds	App. Total	Left	Thru	Right	Peds	App. Total	Left	Thru	Right	Peds	App. Total	
Peak Hour Analysis From 06:00 to 08:45 - Peak 1 of 1																					
Peak Hour for Entire Intersection Begins at 06:15																					
06:15	1	499	28	0	528	0	0	0	0	0	7	63	0	0	70	1	0	11	0	12	610
06:30	0	444	22	0	466	0	0	0	0	0	6	88	0	0	94	2	0	18	0	20	580
06:45	0	444	46	0	490	1	0	0	0	1	9	89	0	0	98	1	0	16	0	17	606
07:00	1	406	17	0	424	0	0	0	0	0	4	94	0	0	98	3	0	21	0	24	546
Total Volume	2	1793	113	0	1908	1	0	0	0	1	26	334	0	0	360	7	0	66	0	73	2342
% App. Total	0.1	94	5.9	0		100	0	0	0		7.2	92.8	0	0		9.6	0	90.4	0		
PHF	.500	.898	.614	.000	.903	.250	.000	.000	.000	.250	.722	.888	.000	.000	.918	.583	.000	.786	.000	.760	.960

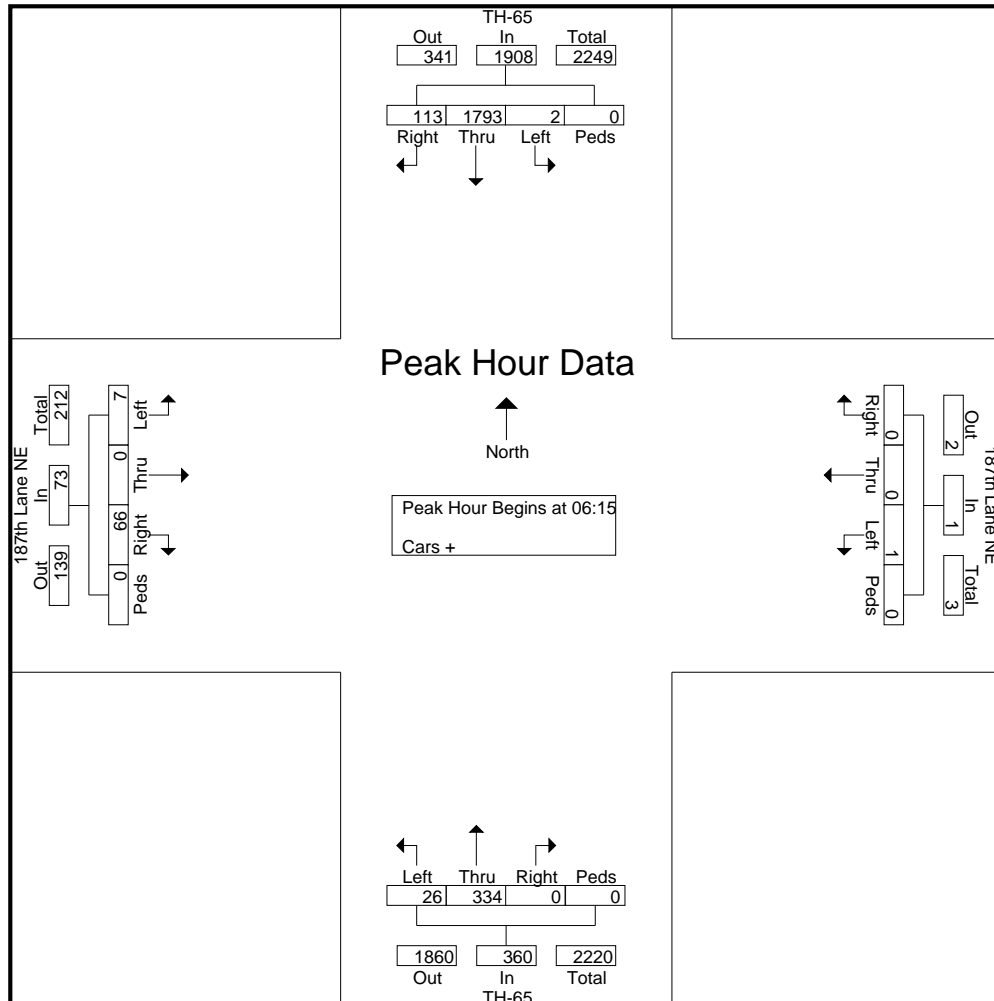

# MN Dept of Transportation

TRAFFIC DATA COLLECTION - Metro

TH-65 at 187th Lane NE  
 Ref.Pt.: 023.164  
 video CL  
 TURN MOVEMENT COUNT

File Name : TH-65 at 187th Lane NE 2015  
 Site Code : CL  
 Start Date : 2/5/2015  
 Page No : 4

Start Time	TH-65 Southbound					187th Lane NE Westbound					TH-65 Northbound					187th Lane NE Eastbound					Int. Total
	Left	Thru	Right	Peds	App. Total	Left	Thru	Right	Peds	App. Total	Left	Thru	Right	Peds	App. Total	Left	Thru	Right	Peds	App. Total	
Peak Hour Analysis From 15:00 to 17:45 - Peak 1 of 1																					
Peak Hour for Entire Intersection Begins at 16:15																					
16:15	10	186	10	0	206	0	1	1	0	2	8	479	2	0	489	18	3	6	0	27	724
16:30	4	154	10	0	168	6	1	0	0	7	10	472	3	0	485	27	4	12	0	43	703
16:45	4	195	12	0	211	0	0	0	0	0	7	518	1	0	526	14	3	15	0	32	769
17:00	2	157	6	0	165	2	0	0	0	2	14	481	2	0	497	19	0	22	0	41	705
Total Volume	20	692	38	0	750	8	2	1	0	11	39	1950	8	0	1997	78	10	55	0	143	2901
% App. Total	2.7	92.3	5.1	0		72.7	18.2	9.1	0		2	97.6	0.4	0		54.5	7	38.5	0		
PHF	.500	.887	.792	.000	.889	.333	.500	.250	.000	.393	.696	.941	.667	.000	.949	.722	.625	.625	.000	.831	.943

