



MINNESOTA DEPT OF TRANSPORTATION

TRAFFIC DATA COLLECTION - METRO

TH-65 at 169th Ave NE. (Ham Lake)
 REF.PT.: 020.943
 JAMAR # 631 /632 RE/DR
 TURN MOVEMENT COUNT

File Name : TH-65 at 169th Ave NE 2007
 Site Code : 00000000
 Start Date : 5/9/2007
 Page No : 1

Groups Printed- Cars & Trucks

Start Time	TH-65 Southbound				169th AVE NE Westbound				TH-65 Northbound				169th AVE NE Eastbound				Int. Total
	Left	Thru	Right	Peds	Left	Thru	Right	Peds	Left	Thru	Right	Peds	Left	Thru	Right	Peds	
06:00	1	538	0	0	19	0	0	0	1	44	1	0	1	0	4	0	609
06:15	3	573	0	0	14	1	0	0	7	73	1	0	3	0	6	0	681
06:30	3	560	0	0	18	1	2	0	1	102	3	0	4	0	9	1	704
06:45	2	521	1	0	30	1	1	0	1	96	5	0	2	0	4	0	664
Total	9	2192	1	0	81	3	3	0	10	315	10	0	10	0	23	1	2658
07:00	2	429	0	0	15	2	6	0	4	107	2	0	4	0	17	0	588
07:15	6	492	0	0	28	2	4	0	4	108	7	0	3	1	11	0	666
07:30	2	452	1	0	27	1	3	0	3	125	7	0	5	1	6	0	633
07:45	2	398	0	0	16	1	2	0	7	146	3	0	3	0	9	0	587
Total	12	1771	1	0	86	6	15	0	18	486	19	0	15	2	43	0	2474
08:00	2	327	1	0	10	0	2	0	3	121	9	0	3	0	4	0	482
08:15	2	298	1	0	12	0	2	0	2	111	4	0	3	0	7	0	442
08:30	1	237	0	0	17	2	3	0	2	95	6	0	2	0	8	0	373
08:45	4	242	1	0	9	0	1	0	3	128	6	0	1	1	1	0	397
Total	9	1104	3	0	48	2	8	0	10	455	25	0	9	1	20	0	1694
*** BREAK ***																	
14:45	6	179	1	0	13	0	8	0	12	311	22	0	4	0	3	0	559
Total	6	179	1	0	13	0	8	0	12	311	22	0	4	0	3	0	559
15:00	3	168	0	0	11	0	6	0	9	371	13	0	1	1	3	0	586
15:15	10	188	3	0	8	1	3	0	9	379	20	0	8	1	1	0	631
15:30	5	177	1	0	8	1	6	0	14	413	22	0	2	1	3	0	653
15:45	6	216	0	0	7	1	2	0	10	460	26	0	7	2	4	0	741
Total	24	749	4	0	34	3	17	0	42	1623	81	0	18	5	11	0	2611
16:00	11	172	2	0	7	1	2	0	17	508	25	0	6	1	6	0	758
16:15	2	172	2	0	10	1	4	0	15	615	24	0	3	1	4	0	853
16:30	5	192	2	1	7	0	2	0	13	521	14	0	4	1	7	0	769
16:45	8	207	4	0	9	1	3	0	14	535	13	0	1	1	2	0	798
Total	26	743	10	1	33	3	11	0	59	2179	76	0	14	4	19	0	3178
17:00	7	213	0	0	7	1	5	0	19	586	18	0	7	2	5	0	870
17:15	6	206	2	0	8	1	6	0	11	514	28	1	2	0	7	0	792
17:30	4	166	2	0	10	0	7	0	24	599	27	0	7	1	3	0	850
17:45	10	182	1	0	13	0	10	0	14	489	12	0	2	4	2	0	739
Total	27	767	5	0	38	2	28	0	68	2188	85	1	18	7	17	0	3251
Grand Total	113	7505	25	1	333	19	90	0	219	7557	318	1	88	19	136	1	16425
Apprch %	1.5	98.2	0.3	0	75.3	4.3	20.4	0	2.7	93.4	3.9	0	36.1	7.8	55.7	0.4	
Total %	0.7	45.7	0.2	0	2	0.1	0.5	0	1.3	46	1.9	0	0.5	0.1	0.8	0	



MINNESOTA DEPT OF TRANSPORTATION

TRAFFIC DATA COLLECTION - METRO

TH-65 at 169th Ave NE. (Ham Lake)
 REF.PT.: 020.943
 JAMAR # 631 /632 RE/DR
 TURN MOVEMENT COUNT

File Name : TH-65 at 169th Ave NE 2007
 Site Code : 00000000
 Start Date : 5/9/2007
 Page No : 2

Start Time	TH-65 Southbound					169th AVE NE Westbound					TH-65 Northbound					169th AVE NE Eastbound					Int. Total
	Left	Thru	Right	Peds	App. Total	Left	Thru	Right	Peds	App. Total	Left	Thru	Right	Peds	App. Total	Left	Thru	Right	Peds	App. Total	
Peak Hour Analysis From 06:00 to 08:45 - Peak 1 of 1																					
Peak Hour for Entire Intersection Begins at 06:00																					
06:00	1	538	0	0	539	19	0	0	0	19	1	44	1	0	46	1	0	4	0	5	609
06:15	3	573	0	0	576	14	1	0	0	15	7	73	1	0	81	3	0	6	0	9	681
06:30	3	560	0	0	563	18	1	2	0	21	1	102	3	0	106	4	0	9	1	14	704
06:45	2	521	1	0	524	30	1	1	0	32	1	96	5	0	102	2	0	4	0	6	664
Total Volume	9	2192	1	0	2202	81	3	3	0	87	10	315	10	0	335	10	0	23	1	34	2658
% App. Total	0.4	99.5	0	0		93.1	3.4	3.4	0		3	94	3	0		29.4	0	67.6	2.9		
PHF	.750	.956	.250	.000	.956	.675	.750	.375	.000	.680	.357	.772	.500	.000	.790	.625	.000	.639	.250	.607	.944

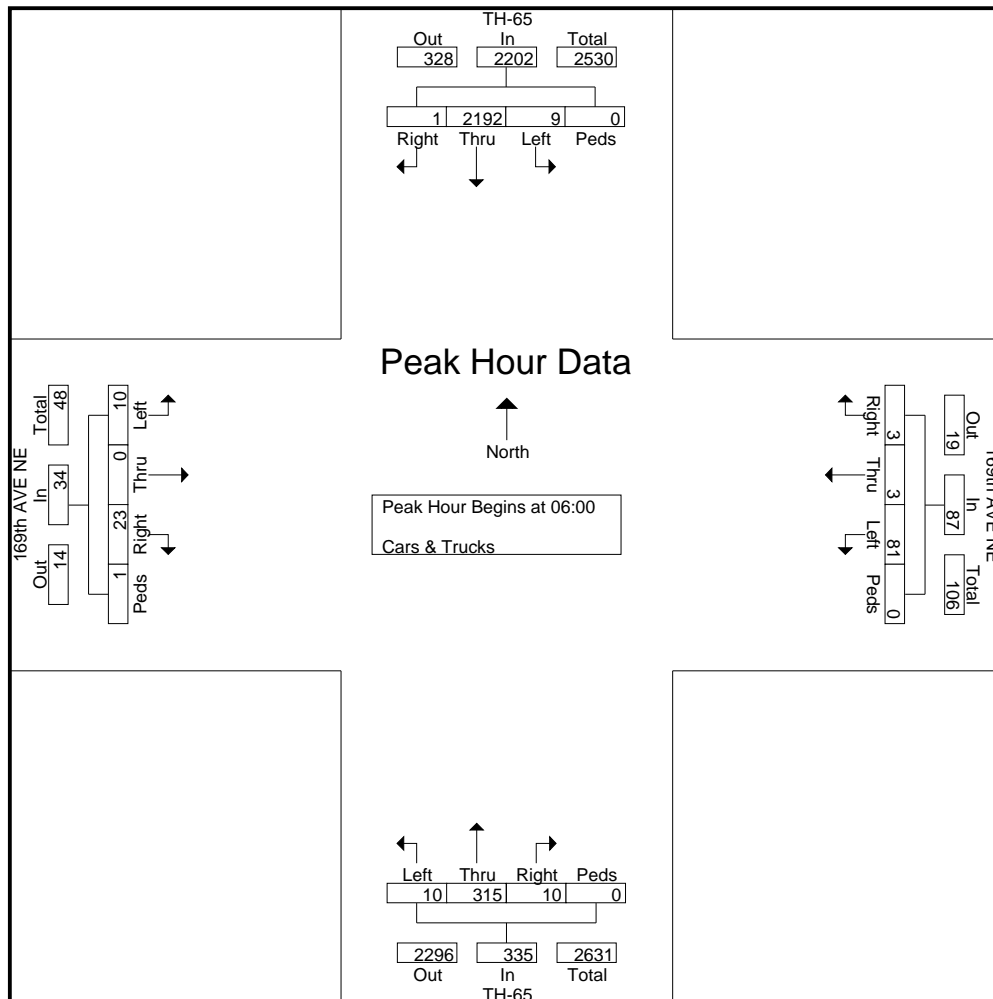



MINNESOTA DEPT OF TRANSPORTATION

TRAFFIC DATA COLLECTION - METRO

TH-65 at 169th Ave NE. (Ham Lake)
 REF.PT.: 020.943
 JAMAR # 631 /632 RE/DR
 TURN MOVEMENT COUNT

File Name : TH-65 at 169th Ave NE 2007
 Site Code : 00000000
 Start Date : 5/9/2007
 Page No : 3

Start Time	TH-65 Southbound					169th AVE NE Westbound					TH-65 Northbound					169th AVE NE Eastbound					Int. Total
	Left	Thru	Right	Peds	App. Total	Left	Thru	Right	Peds	App. Total	Left	Thru	Right	Peds	App. Total	Left	Thru	Right	Peds	App. Total	
Peak Hour Analysis From 15:00 to 17:45 - Peak 1 of 1																					
Peak Hour for Entire Intersection Begins at 16:45																					
16:45	8	207	4	0	219	9	1	3	0	13	14	535	13	0	562	1	1	2	0	4	798
17:00	7	213	0	0	220	7	1	5	0	13	19	586	18	0	623	7	2	5	0	14	870
17:15	6	206	2	0	214	8	1	6	0	15	11	514	28	1	554	2	0	7	0	9	792
17:30	4	166	2	0	172	10	0	7	0	17	24	599	27	0	650	7	1	3	0	11	850
Total Volume	25	792	8	0	825	34	3	21	0	58	68	2234	86	1	2389	17	4	17	0	38	3310
% App. Total	3	96	1	0		58.6	5.2	36.2	0		2.8	93.5	3.6	0		44.7	10.5	44.7	0		
PHF	.781	.930	.500	.000	.938	.850	.750	.750	.000	.853	.708	.932	.768	.250	.919	.607	.500	.607	.000	.679	.951

