



MINNESOTA DEPT OF TRANSPORTATION

TRAFFIC DATA COLLECTION - METRO

loc: th 65 @ cloverleaf dr 2003
 ref pt:
 data collected by: alliant eng
 tmc: am noon pm

File Name : T.H. 65 at Cloverleaf
 Site Code : 00000022
 Start Date : 8/19/2003
 Page No : 1

Groups Printed- Unshifted

Start Time	T.H. 65 Southbound					Cloverleaf Pkwy Westbound					T.H. 65 Northbound					Cloverleaf Pkwy Eastbound					Int. Total
	Left	Thru	Right	Peds	App. Total	Left	Thru	Right	Peds	App. Total	Left	Thru	Right	Peds	App. Total	Left	Thru	Right	Peds	App. Total	
06:00	0	560	0	0	560	20	1	4	0	25	2	120	26	0	148	0	15	50	0	65	798
06:15	17	593	11	0	621	26	5	3	0	34	3	198	38	1	240	1	15	76	0	92	987
06:30	22	569	2	0	593	68	2	1	0	71	1	203	29	0	233	0	22	80	0	102	999
06:45	24	478	3	0	505	49	1	0	0	50	3	202	45	0	250	0	27	70	0	97	902
Total	63	2200	16	0	2279	163	9	8	0	180	9	723	138	1	871	1	79	276	0	356	3686
07:00	8	581	1	0	590	60	4	2	0	66	2	193	59	0	254	0	23	64	0	87	997
07:15	25	630	3	0	658	75	2	2	0	79	10	232	41	1	284	1	25	66	0	92	1113
07:30	18	567	3	0	588	56	3	4	0	63	6	216	41	0	263	0	17	49	0	66	980
07:45	17	535	3	0	555	35	6	4	0	45	16	211	55	0	282	1	15	42	0	58	940
Total	68	2313	10	0	2391	226	15	12	0	253	34	852	196	1	1083	2	80	221	0	303	4030
08:00	14	556	3	0	573	42	2	0	0	44	15	190	41	0	246	0	14	58	0	72	935
08:15	20	405	2	0	427	45	2	0	0	47	3	209	28	0	240	2	11	38	0	51	765
08:30	6	372	6	0	384	45	6	0	0	51	4	220	49	0	273	0	15	46	0	61	769
08:45	0	0	0	0	0	37	7	1	0	45	6	194	43	0	243	0	0	0	0	0	288
Total	40	1333	11	0	1384	169	17	1	0	187	28	813	161	0	1002	2	40	142	0	184	2757
11:00	7	352	5	0	364	54	12	4	0	70	2	296	59	1	358	4	12	22	0	38	830
11:15	12	244	6	0	262	58	5	8	0	71	19	306	61	0	386	7	16	25	0	48	767
11:30	41	298	2	0	341	57	15	16	0	88	25	324	47	0	396	1	19	20	0	40	865
11:45	42	299	13	0	354	83	14	17	0	114	10	322	72	0	404	7	20	28	0	55	927
Total	102	1193	26	0	1321	252	46	45	0	343	56	1248	239	1	1544	19	67	95	0	181	3389
12:00	43	220	4	0	267	75	8	13	0	96	27	300	53	0	380	7	19	26	0	52	795
12:15	44	252	2	0	298	63	16	6	0	85	23	312	60	2	397	5	23	42	0	70	850
12:30	28	263	6	0	297	71	22	13	0	106	23	301	63	2	389	3	18	34	0	55	847
12:45	37	260	6	0	303	62	19	4	0	85	30	286	65	0	381	3	24	36	0	63	832
Total	152	995	18	0	1165	271	65	36	0	372	103	1199	241	4	1547	18	84	138	0	240	3324



MINNESOTA DEPT OF TRANSPORTATION

TRAFFIC DATA COLLECTION - METRO

File Name : T.H. 65 at Cloverleaf
 Site Code : 00000022
 Start Date : 8/19/2003
 Page No : 2

Groups Printed- Unshifted

Start Time	T.H. 65 Southbound					Cloverleaf Pkwy Westbound					T.H. 65 Northbound					Cloverleaf Pkwy Eastbound					Int. Total
	Left	Thru	Right	Peds	App. Total	Left	Thru	Right	Peds	App. Total	Left	Thru	Right	Peds	App. Total	Left	Thru	Right	Peds	App. Total	
15:00	19	264	38	0	321	59	19	3	0	81	15	465	68	0	548	4	16	17	0	37	987
15:15	28	337	2	0	367	47	26	7	0	80	12	559	79	0	650	5	12	33	0	50	1147
15:30	18	272	5	0	295	59	22	6	0	87	15	567	60	0	642	2	17	20	2	41	1065
15:45	13	270	1	0	284	49	28	9	0	86	20	501	74	2	597	7	10	34	0	51	1018
Total	78	1143	46	0	1267	214	95	25	0	334	62	2092	281	2	2437	18	55	104	2	179	4217
16:00	16	239	5	0	260	70	25	11	0	106	14	504	64	0	582	6	13	38	0	57	1005
16:15	18	212	1	0	231	64	29	14	0	107	32	617	78	0	727	2	3	18	0	23	1088
16:30	17	320	5	0	342	65	36	41	0	142	40	564	93	0	697	6	26	29	0	61	1242
16:45	12	276	1	0	289	65	39	34	0	138	34	565	92	0	691	7	9	16	0	32	1150
Total	63	1047	12	0	1122	264	129	100	0	493	120	2250	327	0	2697	21	51	101	0	173	4485
17:00	20	315	8	0	343	60	33	9	0	102	25	541	73	0	639	7	17	40	0	64	1148
17:15	16	313	4	0	333	43	41	37	0	121	32	592	93	0	717	8	9	36	0	53	1224
17:30	15	267	2	0	284	42	40	12	0	94	27	535	65	1	628	15	15	40	0	70	1076
17:45	15	300	3	0	318	33	24	16	0	73	21	578	50	0	649	5	14	32	0	51	1091
Total	66	1195	17	0	1278	178	138	74	0	390	105	2246	281	1	2633	35	55	148	0	238	4539
Grand Total	632	11419	156	0	12207	1737	514	301	0	2552	517	11423	1864	10	13814	116	511	1225	2	1854	30427
Apprch %	5.2	93.5	1.3	0		68.1	20.1	11.8	0		3.7	82.7	13.5	0.1		6.3	27.6	66.1	0.1		
Total %	2.1	37.5	0.5	0	40.1	5.7	1.7	1	0	8.4	1.7	37.5	6.1	0	45.4	0.4	1.7	4	0	6.1	



MINNESOTA DEPT OF TRANSPORTATION

TRAFFIC DATA COLLECTION - METRO

File Name : T.H. 65 at Cloverleaf
 Site Code : 00000022
 Start Date : 8/19/2003
 Page No : 3

Start Time	T.H. 65 Southbound					Cloverleaf Pkwy Westbound					T.H. 65 Northbound					Cloverleaf Pkwy Eastbound					Int. Total
	Left	Thru	Right	Peds	App. Total	Left	Thru	Right	Peds	App. Total	Left	Thru	Right	Peds	App. Total	Left	Thru	Right	Peds	App. Total	
Peak Hour Analysis From 06:00 to 09:45 - Peak 1 of 1																					
Peak Hour for Entire Intersection Begins at 07:00																					
07:00	8	581	1	0	590	60	4	2	0	66	2	193	59	0	254	0	23	64	0	87	997
07:15	25	630	3	0	658	75	2	2	0	79	10	232	41	1	284	1	25	66	0	92	1113
07:30	18	567	3	0	588	56	3	4	0	63	6	216	41	0	263	0	17	49	0	66	980
07:45	17	535	3	0	555	35	6	4	0	45	16	211	55	0	282	1	15	42	0	58	940
Total Volume	68	2313	10	0	2391	226	15	12	0	253	34	852	196	1	1083	2	80	221	0	303	4030
% App. Total	2.8	96.7	0.4	0		89.3	5.9	4.7	0		3.1	78.7	18.1	0.1		0.7	26.4	72.9	0		
PHF	.680	.918	.833	.000	.908	.753	.625	.750	.000	.801	.531	.918	.831	.250	.953	.500	.800	.837	.000	.823	.905

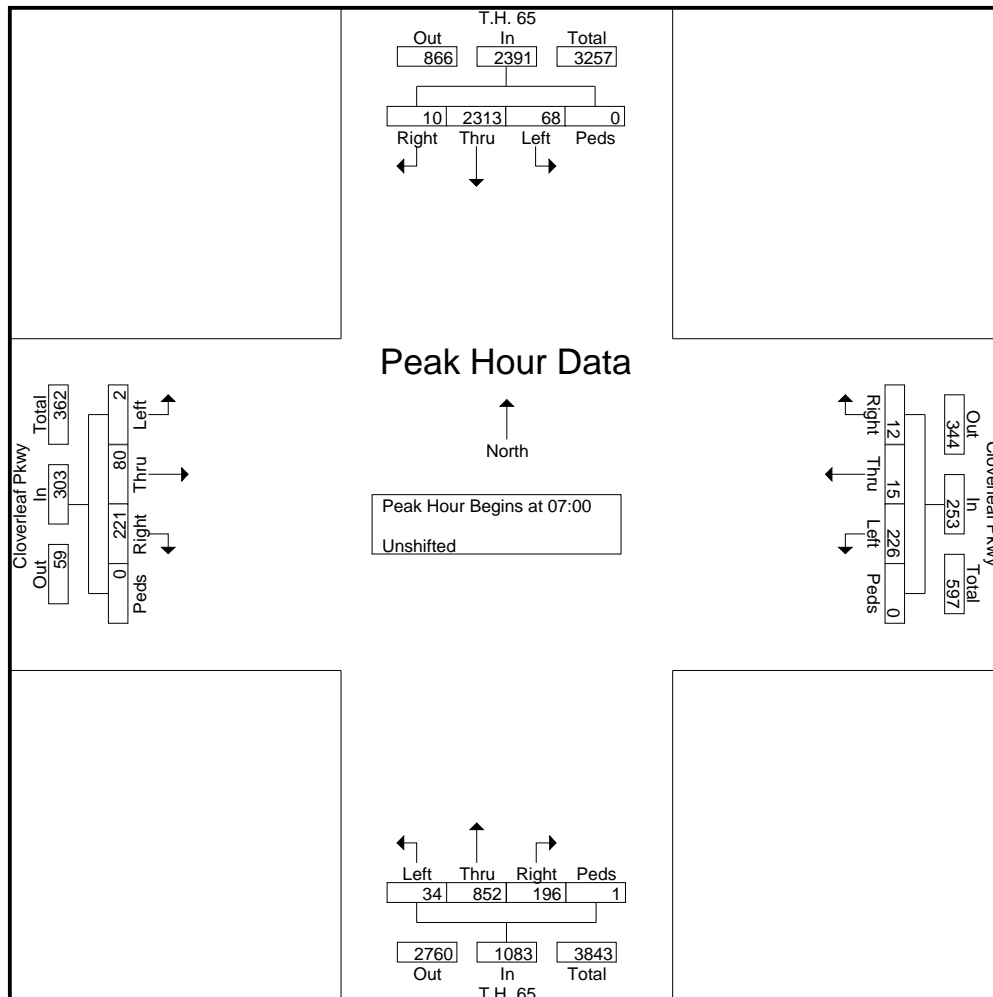



MINNESOTA DEPT OF TRANSPORTATION

TRAFFIC DATA COLLECTION - METRO

File Name : T.H. 65 at Cloverleaf
 Site Code : 00000022
 Start Date : 8/19/2003
 Page No : 4

Start Time	T.H. 65 Southbound					Cloverleaf Pkwy Westbound					T.H. 65 Northbound					Cloverleaf Pkwy Eastbound					Int. Total
	Left	Thru	Right	Peds	App. Total	Left	Thru	Right	Peds	App. Total	Left	Thru	Right	Peds	App. Total	Left	Thru	Right	Peds	App. Total	
Peak Hour Analysis From 10:00 to 13:45 - Peak 1 of 1																					
Peak Hour for Entire Intersection Begins at 11:30																					
11:30	41	298	2	0	341	57	15	16	0	88	25	324	47	0	396	1	19	20	0	40	865
11:45	42	299	13	0	354	83	14	17	0	114	10	322	72	0	404	7	20	28	0	55	927
12:00	43	220	4	0	267	75	8	13	0	96	27	300	53	0	380	7	19	26	0	52	795
12:15	44	252	2	0	298	63	16	6	0	85	23	312	60	2	397	5	23	42	0	70	850
Total Volume	170	1069	21	0	1260	278	53	52	0	383	85	1258	232	2	1577	20	81	116	0	217	3437
% App. Total	13.5	84.8	1.7	0		72.6	13.8	13.6	0		5.4	79.8	14.7	0.1		9.2	37.3	53.5	0		
PHF	.966	.894	.404	.000	.890	.837	.828	.765	.000	.840	.787	.971	.806	.250	.976	.714	.880	.690	.000	.775	.927

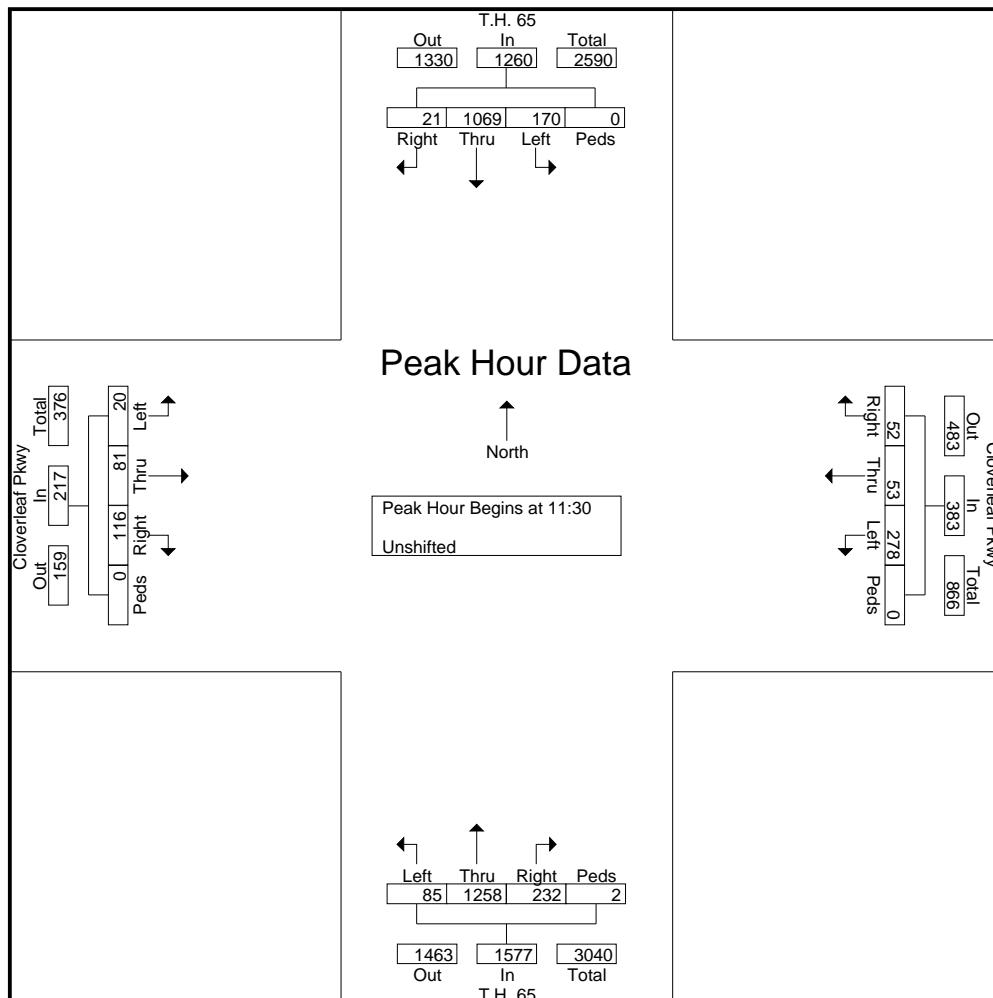



MINNESOTA DEPT OF TRANSPORTATION

TRAFFIC DATA COLLECTION - METRO

File Name : T.H. 65 at Cloverleaf
 Site Code : 00000022
 Start Date : 8/19/2003
 Page No : 5

Start Time	T.H. 65 Southbound					Cloverleaf Pkwy Westbound					T.H. 65 Northbound					Cloverleaf Pkwy Eastbound					Int. Total
	Left	Thru	Right	Peds	App. Total	Left	Thru	Right	Peds	App. Total	Left	Thru	Right	Peds	App. Total	Left	Thru	Right	Peds	App. Total	
Peak Hour Analysis From 14:00 to 17:45 - Peak 1 of 1																					
Peak Hour for Entire Intersection Begins at 16:30																					
16:30	17	320	5	0	342	65	36	41	0	142	40	564	93	0	697	6	26	29	0	61	1242
16:45	12	276	1	0	289	65	39	34	0	138	34	565	92	0	691	7	9	16	0	32	1150
17:00	20	315	8	0	343	60	33	9	0	102	25	541	73	0	639	7	17	40	0	64	1148
17:15	16	313	4	0	333	43	41	37	0	121	32	592	93	0	717	8	9	36	0	53	1224
Total Volume	65	1224	18	0	1307	233	149	121	0	503	131	2262	351	0	2744	28	61	121	0	210	4764
% App. Total	5	93.6	1.4	0		46.3	29.6	24.1	0		4.8	82.4	12.8	0		13.3	29	57.6	0		
PHF	.813	.956	.563	.000	.953	.896	.909	.738	.000	.886	.819	.955	.944	.000	.957	.875	.587	.756	.000	.820	.959

