



MINNESOTA DEPT OF TRANSPORTATION

TRAFFIC DATA COLLECTION - METRO

loc: th 65 @ osborne rd 2003
 ref pt: 009+00.167
 data collected by: alliant eng
 turn movement count

File Name : T.H. 65 at Osborne
 Site Code : 00000016
 Start Date : 8/13/2003
 Page No : 1

Groups Printed- Unshifted

Start Time	T.H. 65 Southbound					Osborne Rd. Westbound					T.H. 65 Northbound					Osborne Rd. Eastbound					Int. Total
	Left	Thru	Right	Peds	App. Total	Left	Thru	Right	Peds	App. Total	Left	Thru	Right	Peds	App. Total	Left	Thru	Right	Peds	App. Total	
06:00	9	322	18	0	349	5	12	6	0	23	5	61	0	0	66	6	10	23	0	39	477
06:15	10	373	28	0	411	13	19	7	0	39	6	85	0	0	91	7	9	9	0	25	566
06:30	13	477	32	0	522	10	19	10	0	39	15	99	0	0	114	11	13	16	0	40	715
06:45	11	505	47	0	563	14	28	5	0	47	22	119	0	0	141	17	12	21	0	50	801
Total	43	1677	125	0	1845	42	78	28	0	148	48	364	0	0	412	41	44	69	0	154	2559
07:00	7	464	34	1	506	10	31	9	1	51	20	106	0	0	126	20	18	21	0	59	742
07:15	12	540	29	0	581	10	29	5	0	44	26	88	0	0	114	18	26	19	0	63	802
07:30	12	473	47	0	532	18	30	9	0	57	37	146	0	0	183	30	17	19	0	66	838
07:45	20	441	44	0	505	26	39	12	1	78	34	145	0	2	181	18	30	25	0	73	837
Total	51	1918	154	1	2124	64	129	35	2	230	117	485	0	2	604	86	91	84	0	261	3219
08:00	13	333	28	0	374	12	29	12	0	53	19	120	0	0	139	16	24	18	0	58	624
08:15	27	314	32	0	373	10	25	12	0	47	34	128	0	0	162	9	12	20	0	41	623
08:30	20	281	35	0	336	9	18	18	0	45	14	155	6	0	175	16	20	13	0	49	605
08:45	18	181	19	0	218	5	46	13	0	64	23	150	6	0	179	21	20	18	0	59	520
Total	78	1109	114	0	1301	36	118	55	0	209	90	553	12	0	655	62	76	69	0	207	2372
11:00	18	161	19	3	201	17	36	16	3	72	30	233	12	0	275	35	42	17	0	94	642
11:15	31	198	31	0	260	16	36	22	0	74	28	196	10	2	236	25	29	41	0	95	665
11:30	29	189	21	1	240	16	43	20	2	81	31	212	12	1	256	33	34	36	0	103	680
11:45	25	217	28	1	271	23	47	26	1	97	31	220	17	0	268	35	38	24	0	97	733
Total	103	765	99	5	972	72	162	84	6	324	120	861	51	3	1035	128	143	118	0	389	2720
12:00	43	202	23	0	268	13	48	33	0	94	38	240	16	1	295	36	52	32	0	120	777
12:15	26	175	22	1	224	36	45	34	0	115	46	172	0	0	218	36	49	26	0	111	668
12:30	31	226	23	1	281	24	39	31	1	95	34	215	0	0	249	29	42	19	0	90	715
12:45	29	160	14	1	204	36	43	35	1	115	26	201	4	2	233	30	38	32	0	100	652
Total	129	763	82	3	977	109	175	133	2	419	144	828	20	3	995	131	181	109	0	421	2812



MINNESOTA DEPT OF TRANSPORTATION

TRAFFIC DATA COLLECTION - METRO

File Name : T.H. 65 at Osborne
 Site Code : 00000016
 Start Date : 8/13/2003
 Page No : 2

Groups Printed- Unshifted

Start Time	T.H. 65 Southbound					Osborne Rd. Westbound					T.H. 65 Northbound					Osborne Rd. Eastbound					Int. Total
	Left	Thru	Right	Peds	App. Total	Left	Thru	Right	Peds	App. Total	Left	Thru	Right	Peds	App. Total	Left	Thru	Right	Peds	App. Total	
15:00	17	207	11	0	235	17	58	42	0	117	37	353	16	0	406	40	47	24	0	111	869
15:15	18	195	23	0	236	12	25	26	0	63	36	286	17	0	339	42	53	30	0	125	763
15:30	13	191	21	0	225	19	54	27	0	100	40	425	4	0	469	45	64	32	0	141	935
15:45	22	173	21	0	216	20	44	40	0	104	33	310	15	0	358	44	49	29	0	122	800
Total	70	766	76	0	912	68	181	135	0	384	146	1374	52	0	1572	171	213	115	0	499	3367
16:00	32	178	27	3	240	18	56	30	2	106	30	376	3	0	409	57	41	38	0	136	891
16:15	27	191	18	0	236	26	52	30	1	109	46	343	3	0	392	36	45	34	0	115	852
16:30	32	194	31	1	258	20	33	45	1	99	38	416	4	2	460	53	65	40	1	159	976
16:45	27	197	30	2	256	13	54	32	2	101	46	321	81	0	448	41	54	33	0	128	933
Total	118	760	106	6	990	77	195	137	6	415	160	1456	91	2	1709	187	205	145	1	538	3652
17:00	20	202	24	0	246	24	71	34	0	129	37	452	11	1	501	42	51	40	0	133	1009
17:15	23	185	21	0	229	16	42	31	1	90	55	433	5	0	493	34	61	26	1	122	934
17:30	35	194	26	0	255	12	52	41	2	107	32	399	7	0	438	37	55	30	0	122	922
17:45	31	184	13	0	228	11	54	30	0	95	35	361	0	0	396	38	46	17	0	101	820
Total	109	765	84	0	958	63	219	136	3	421	159	1645	23	1	1828	151	213	113	1	478	3685
Grand Total	701	8523	840	15	10079	531	1257	743	19	2550	984	7566	249	11	8810	957	1166	822	2	2947	24386
Apprch %	7	84.6	8.3	0.1		20.8	49.3	29.1	0.7		11.2	85.9	2.8	0.1		32.5	39.6	27.9	0.1		
Total %	2.9	35	3.4	0.1	41.3	2.2	5.2	3	0.1	10.5	4	31	1	0	36.1	3.9	4.8	3.4	0	12.1	



MINNESOTA DEPT OF TRANSPORTATION

TRAFFIC DATA COLLECTION - METRO

File Name : T.H. 65 at Osborne
 Site Code : 00000016
 Start Date : 8/13/2003
 Page No : 3

Start Time	T.H. 65 Southbound					Osborne Rd. Westbound					T.H. 65 Northbound					Osborne Rd. Eastbound					Int. Total
	Left	Thru	Right	Peds	App. Total	Left	Thru	Right	Peds	App. Total	Left	Thru	Right	Peds	App. Total	Left	Thru	Right	Peds	App. Total	
Peak Hour Analysis From 06:00 to 09:45 - Peak 1 of 1																					
Peak Hour for Entire Intersection Begins at 07:00																					
07:00	7	464	34	1	506	10	31	9	1	51	20	106	0	0	126	20	18	21	0	59	742
07:15	12	540	29	0	581	10	29	5	0	44	26	88	0	0	114	18	26	19	0	63	802
07:30	12	473	47	0	532	18	30	9	0	57	37	146	0	0	183	30	17	19	0	66	838
07:45	20	441	44	0	505	26	39	12	1	78	34	145	0	2	181	18	30	25	0	73	837
Total Volume	51	1918	154	1	2124	64	129	35	2	230	117	485	0	2	604	86	91	84	0	261	3219
% App. Total	2.4	90.3	7.3	0		27.8	56.1	15.2	0.9		19.4	80.3	0	0.3		33	34.9	32.2	0		
PHF	.638	.888	.819	.250	.914	.615	.827	.729	.500	.737	.791	.830	.000	.250	.825	.717	.758	.840	.000	.894	.960

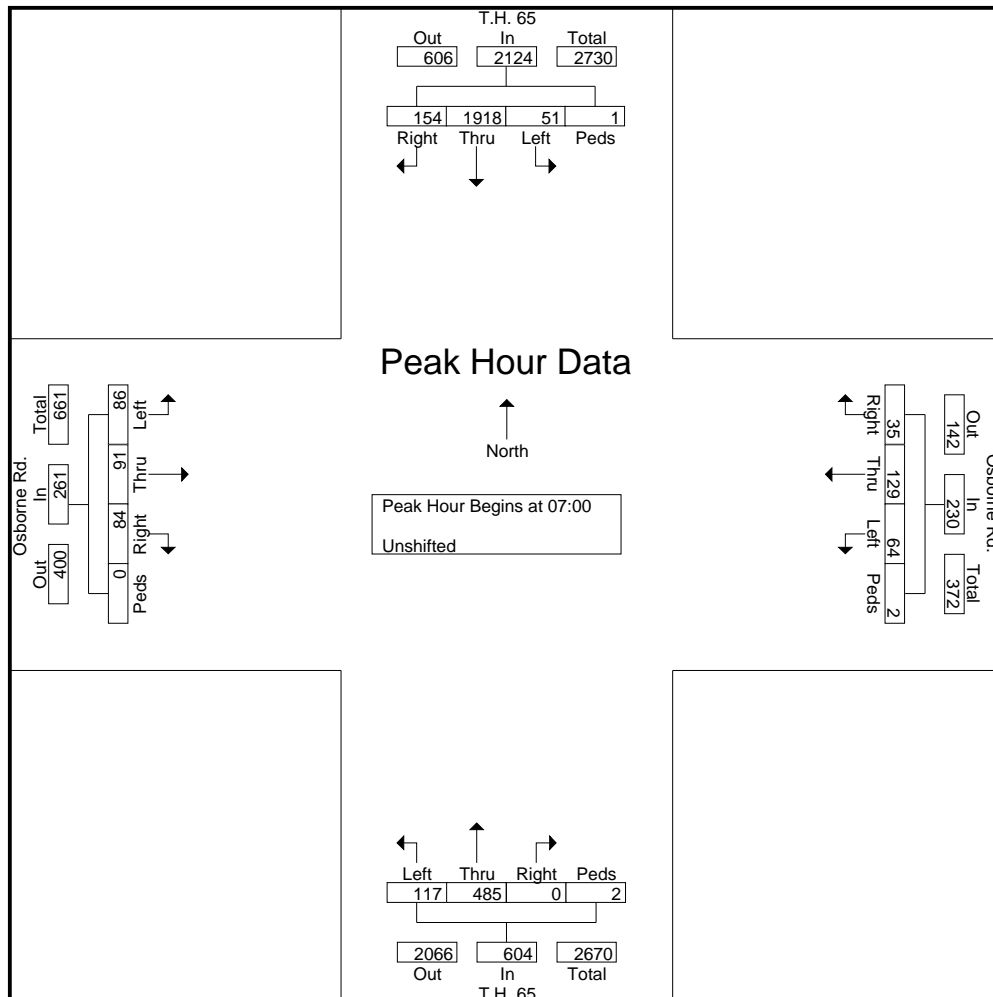



MINNESOTA DEPT OF TRANSPORTATION

TRAFFIC DATA COLLECTION - METRO

File Name : T.H. 65 at Osborne
 Site Code : 00000016
 Start Date : 8/13/2003
 Page No : 4

Start Time	T.H. 65 Southbound					Osborne Rd. Westbound					T.H. 65 Northbound					Osborne Rd. Eastbound					Int. Total
	Left	Thru	Right	Peds	App. Total	Left	Thru	Right	Peds	App. Total	Left	Thru	Right	Peds	App. Total	Left	Thru	Right	Peds	App. Total	
Peak Hour Analysis From 10:00 to 13:45 - Peak 1 of 1																					
Peak Hour for Entire Intersection Begins at 11:45																					
11:45	25	217	28	1	271	23	47	26	1	97	31	220	17	0	268	35	38	24	0	97	733
12:00	43	202	23	0	268	13	48	33	0	94	38	240	16	1	295	36	52	32	0	120	777
12:15	26	175	22	1	224	36	45	34	0	115	46	172	0	0	218	36	49	26	0	111	668
12:30	31	226	23	1	281	24	39	31	1	95	34	215	0	0	249	29	42	19	0	90	715
Total Volume	125	820	96	3	1044	96	179	124	2	401	149	847	33	1	1030	136	181	101	0	418	2893
% App. Total	12	78.5	9.2	0.3		23.9	44.6	30.9	0.5		14.5	82.2	3.2	0.1		32.5	43.3	24.2	0		
PHF	.727	.907	.857	.750	.929	.667	.932	.912	.500	.872	.810	.882	.485	.250	.873	.944	.870	.789	.000	.871	.931

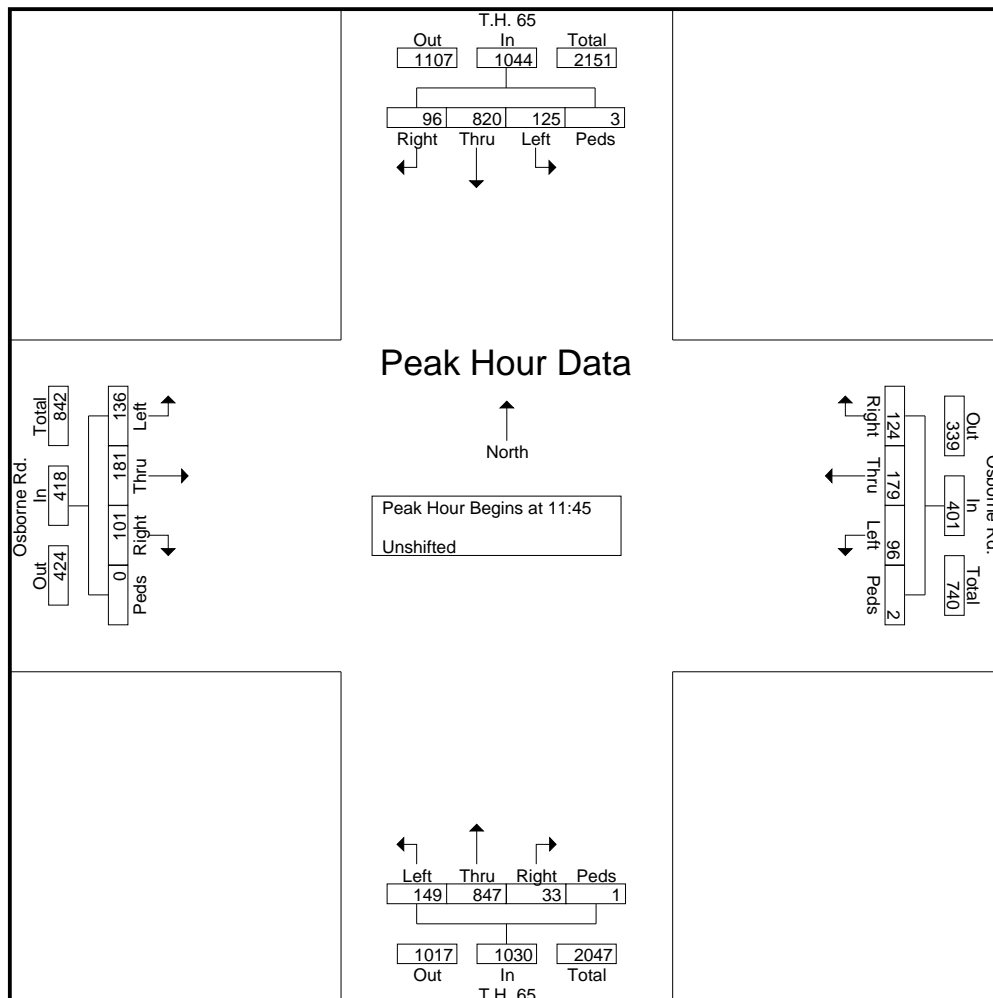



MINNESOTA DEPT OF TRANSPORTATION

TRAFFIC DATA COLLECTION - METRO

File Name : T.H. 65 at Osborne
 Site Code : 00000016
 Start Date : 8/13/2003
 Page No : 5

Start Time	T.H. 65 Southbound					Osborne Rd. Westbound					T.H. 65 Northbound					Osborne Rd. Eastbound					Int. Total
	Left	Thru	Right	Peds	App. Total	Left	Thru	Right	Peds	App. Total	Left	Thru	Right	Peds	App. Total	Left	Thru	Right	Peds	App. Total	
Peak Hour Analysis From 14:00 to 17:45 - Peak 1 of 1																					
Peak Hour for Entire Intersection Begins at 16:30																					
16:30	32	194	31	1	258	20	33	45	1	99	38	416	4	2	460	53	65	40	1	159	976
16:45	27	197	30	2	256	13	54	32	2	101	46	321	81	0	448	41	54	33	0	128	933
17:00	20	202	24	0	246	24	71	34	0	129	37	452	11	1	501	42	51	40	0	133	1009
17:15	23	185	21	0	229	16	42	31	1	90	55	433	5	0	493	34	61	26	1	122	934
Total Volume	102	778	106	3	989	73	200	142	4	419	176	1622	101	3	1902	170	231	139	2	542	3852
% App. Total	10.3	78.7	10.7	0.3		17.4	47.7	33.9	1		9.3	85.3	5.3	0.2		31.4	42.6	25.6	0.4		
PHF	.797	.963	.855	.375	.958	.760	.704	.789	.500	.812	.800	.897	.312	.375	.949	.802	.888	.869	.500	.852	.954

