

# Alliant Engineering Inc Minneapolis, MN 55415

TH-65 at 73rd Ave NE FRIDLEY  
 Ref.Pt.: 008.665  
 Data by Alliant Engineering Inc.  
 TURN MOVEMENT COUNT

File Name : TH-65 at 73rd Ave NE 2009  
 Site Code : 00000006  
 Start Date : 1/7/2009  
 Page No : 1

### Groups Printed- Unshifted

Start Time	TH-65 Southbound				73rd Ave NE Westbound				TH-65 Northbound				73rd Ave NE Eastbound				Int. Total
	Left	Thru	Right	Peds	Left	Thru	Right	Peds	Left	Thru	Right	Peds	Left	Thru	Right	Peds	
06:00	16	271	29	1	11	7	3	1	3	43	4	0	4	24	7	0	424
06:15	14	354	35	0	22	10	6	0	2	87	20	0	11	17	11	0	589
06:30	26	392	32	1	9	16	5	1	14	103	28	0	7	45	7	0	686
06:45	15	370	45	0	21	28	7	0	12	113	29	0	9	28	5	0	682
Total	71	1387	141	2	63	61	21	2	31	346	81	0	31	114	30	0	2381
07:00	18	433	38	0	21	22	5	0	7	113	14	0	4	17	9	1	702
07:15	19	440	29	0	23	30	8	0	7	130	14	0	13	20	16	0	749
07:30	21	450	25	0	17	24	10	0	8	156	21	0	11	25	15	0	783
07:45	32	486	32	0	23	31	8	0	12	157	17	0	13	23	17	0	851
Total	90	1809	124	0	84	107	31	0	34	556	66	0	41	85	57	1	3085
08:00	25	447	38	0	19	21	6	0	8	175	20	0	11	22	15	0	807
08:15	25	362	19	0	27	25	8	2	11	161	12	0	7	29	15	0	703
08:30	21	267	16	0	22	13	6	0	8	161	15	0	5	24	10	0	568
08:45	19	248	15	0	22	18	10	0	10	147	15	0	9	16	12	0	541
Total	90	1324	88	0	90	77	30	2	37	644	62	0	32	91	52	0	2619
09:00	22	222	16	0	15	18	9	0	18	139	18	0	10	23	12	0	522
09:15	10	205	15	0	15	17	8	0	5	144	6	1	9	11	11	1	458
*** BREAK ***																	
Total	32	427	31	0	30	35	17	0	23	283	24	1	19	34	23	1	980
*** BREAK ***																	
10:30	9	171	9	0	17	15	6	0	10	137	8	0	10	10	12	0	414
10:45	8	190	16	0	17	14	11	0	8	151	9	0	16	16	17	2	475
Total	17	361	25	0	34	29	17	0	18	288	17	0	26	26	29	2	889
11:00	17	159	11	2	16	15	15	1	12	157	5	0	16	11	15	0	452
11:15	10	171	11	0	9	20	17	1	7	182	19	0	13	22	13	0	495
11:30	6	180	10	0	15	26	21	0	11	187	12	0	11	21	12	0	512
11:45	11	175	10	0	9	15	18	0	13	166	14	0	12	24	16	1	484
Total	44	685	42	2	49	76	71	2	43	692	50	0	52	78	56	1	1943
12:00	10	130	12	0	15	16	16	0	17	165	19	0	18	30	10	0	458
12:15	17	170	8	0	20	19	16	2	12	180	12	0	12	27	16	0	511
12:30	21	180	14	0	15	14	10	0	20	179	16	0	10	12	13	1	505
12:45	26	216	9	0	15	23	12	0	18	185	26	0	12	17	8	0	567
Total	74	696	43	0	65	72	54	2	67	709	73	0	52	86	47	1	2041
13:00	11	176	16	0	27	17	16	0	10	196	10	0	10	29	6	0	524
13:15	12	157	16	0	22	24	14	0	6	213	14	0	13	15	11	0	517
*** BREAK ***																	
Total	23	333	32	0	49	41	30	0	16	409	24	0	23	44	17	0	1041
*** BREAK ***																	
14:30	13	207	12	0	26	19	10	0	27	333	16	0	65	25	13	0	766
14:45	18	176	16	0	29	19	13	0	16	244	14	0	27	32	21	0	625
Total	31	383	28	0	55	38	23	0	43	577	30	0	92	57	34	0	1391
15:00	12	179	18	0	34	52	34	0	18	302	9	0	35	30	11	0	734
15:15	8	214	9	0	35	33	16	0	19	325	17	0	29	31	19	0	755
15:30	16	197	11	0	31	32	20	3	20	340	27	1	44	46	16	0	804
15:45	22	199	18	0	19	28	13	0	17	365	15	0	37	23	22	0	778
Total	58	789	56	0	119	145	83	3	74	1332	68	1	145	130	68	0	3071

# Alliant Engineering Inc Minneapolis, MN 55415

TH-65 at 73rd Ave NE FRIDLEY  
 Ref.Pt.: 008.665  
 Data by Alliant Engineering Inc.  
 TURN MOVEMENT COUNT

File Name : TH-65 at 73rd Ave NE 2009  
 Site Code : 00000006  
 Start Date : 1/7/2009  
 Page No : 2

### Groups Printed- Unshifted

Start Time	TH-65 Southbound				73rd Ave NE Westbound				TH-65 Northbound				73rd Ave NE Eastbound				Int. Total
	Left	Thru	Right	Peds	Left	Thru	Right	Peds	Left	Thru	Right	Peds	Left	Thru	Right	Peds	
16:00	19	161	11	0	30	16	21	1	19	353	17	0	45	37	8	0	738
16:15	15	192	16	0	29	25	21	0	10	410	22	0	20	34	11	0	805
16:30	18	239	12	0	35	33	27	0	23	409	12	0	42	35	14	0	899
16:45	15	194	18	2	26	21	13	0	20	421	20	0	44	40	8	0	842
Total	67	786	57	2	120	95	82	1	72	1593	71	0	151	146	41	0	3284
17:00	19	201	9	0	32	42	21	0	11	391	26	0	31	31	22	0	836
17:15	14	180	7	0	28	45	26	0	13	359	27	0	36	28	11	0	774
17:30	6	200	12	0	18	17	28	0	7	374	19	0	17	21	23	0	742
17:45	18	210	7	2	19	26	7	0	13	329	23	0	23	26	11	0	714
Total	57	791	35	2	97	130	82	0	44	1453	95	0	107	106	67	0	3066
Grand Total	654	9771	702	8	855	906	541	12	502	8882	661	2	771	997	521	6	25791
Apprch %	5.9	87.8	6.3	0.1	36.9	39.2	23.4	0.5	5	88.4	6.6	0	33.6	43.4	22.7	0.3	
Total %	2.5	37.9	2.7	0	3.3	3.5	2.1	0	1.9	34.4	2.6	0	3	3.9	2	0	

# Alliant Engineering Inc Minneapolis, MN 55415

TH-65 at 73rd Ave NE FRIDLEY  
 Ref.Pt.: 008.665  
 Data by Alliant Engineering Inc.  
 TURN MOVEMENT COUNT

File Name : TH-65 at 73rd Ave NE 2009  
 Site Code : 00000006  
 Start Date : 1/7/2009  
 Page No : 3

Start Time	TH-65 Southbound					73rd Ave NE Westbound					TH-65 Northbound					73rd Ave NE Eastbound					Int. Total
	Left	Thru	Right	Peds	App. Total	Left	Thru	Right	Peds	App. Total	Left	Thru	Right	Peds	App. Total	Left	Thru	Right	Peds	App. Total	
Peak Hour Analysis From 06:00 to 08:45 - Peak 1 of 1																					
Peak Hour for Entire Intersection Begins at 07:15																					
07:15	19	440	29	0	488	23	30	8	0	61	7	130	14	0	151	13	20	16	0	49	749
07:30	21	450	25	0	496	17	24	10	0	51	8	156	21	0	185	11	25	15	0	51	783
07:45	32	486	32	0	550	23	31	8	0	62	12	157	17	0	186	13	23	17	0	53	851
08:00	25	447	38	0	510	19	21	6	0	46	8	175	20	0	203	11	22	15	0	48	807
Total Volume	97	1823	124	0	2044	82	106	32	0	220	35	618	72	0	725	48	90	63	0	201	3190
% App. Total	4.7	89.2	6.1	0		37.3	48.2	14.5	0		4.8	85.2	9.9	0		23.9	44.8	31.3	0		
PHF	.758	.938	.816	.000	.929	.891	.855	.800	.000	.887	.729	.883	.857	.000	.893	.923	.900	.926	.000	.948	.937

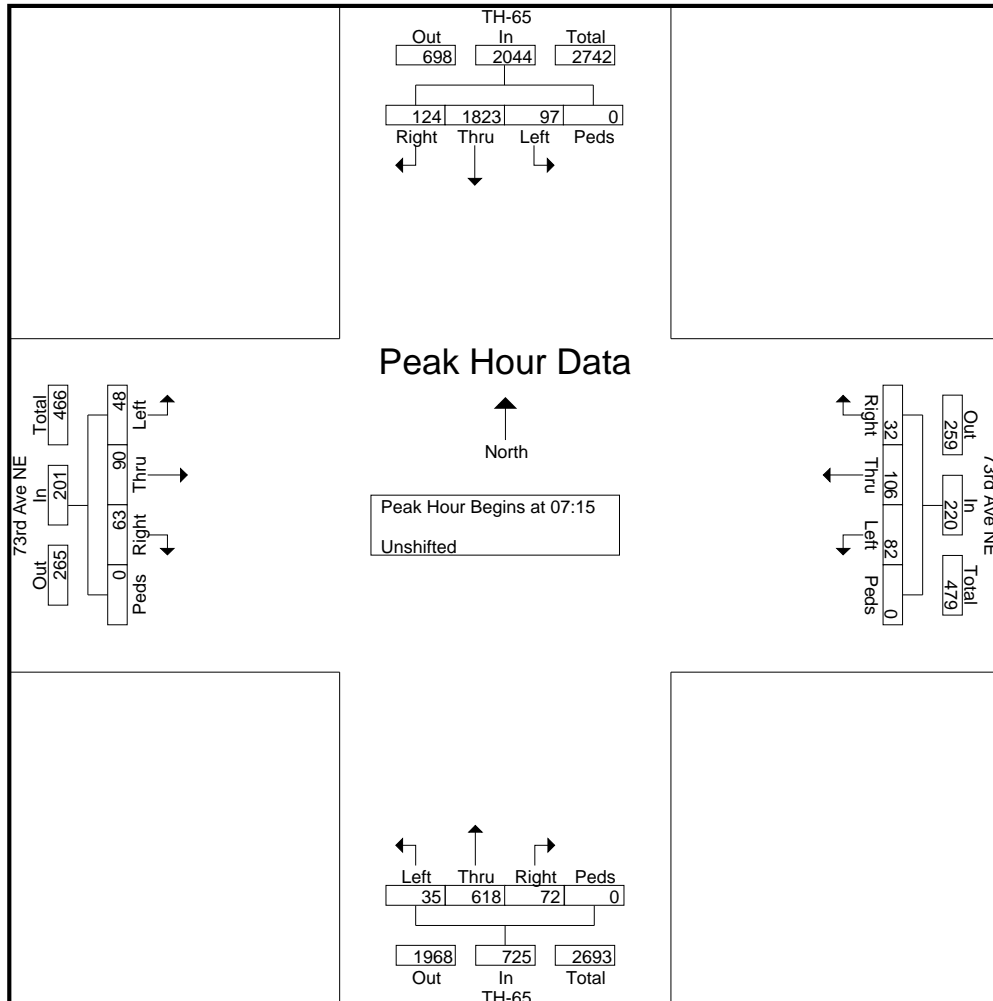

# Alliant Engineering Inc Minneapolis, MN 55415

TH-65 at 73rd Ave NE FRIDLEY  
 Ref.Pt.: 008.665  
 Data by Alliant Engineering Inc.  
 TURN MOVEMENT COUNT

File Name : TH-65 at 73rd Ave NE 2009  
 Site Code : 00000006  
 Start Date : 1/7/2009  
 Page No : 4

Start Time	TH-65 Southbound					73rd Ave NE Westbound					TH-65 Northbound					73rd Ave NE Eastbound					Int. Total
	Left	Thru	Right	Peds	App. Total	Left	Thru	Right	Peds	App. Total	Left	Thru	Right	Peds	App. Total	Left	Thru	Right	Peds	App. Total	
Peak Hour Analysis From 15:00 to 17:45 - Peak 1 of 1																					
Peak Hour for Entire Intersection Begins at 16:15																					
16:15	15	192	16	0	223	29	25	21	0	75	10	410	22	0	442	20	34	11	0	65	805
16:30	18	239	12	0	269	35	33	27	0	95	23	409	12	0	444	42	35	14	0	91	899
16:45	15	194	18	2	229	26	21	13	0	60	20	421	20	0	461	44	40	8	0	92	842
17:00	19	201	9	0	229	32	42	21	0	95	11	391	26	0	428	31	31	22	0	84	836
Total Volume	67	826	55	2	950	122	121	82	0	325	64	1631	80	0	1775	137	140	55	0	332	3382
% App. Total	7.1	86.9	5.8	0.2		37.5	37.2	25.2	0		3.6	91.9	4.5	0		41.3	42.2	16.6	0		
PHF	.882	.864	.764	.250	.883	.871	.720	.759	.000	.855	.696	.969	.769	.000	.963	.778	.875	.625	.000	.902	.940

