



MINNESOTA DEPT OF TRANSPORTATION

TRAFFIC DATA COLLECTION - METRO

Loc: th 65 @ Moore Lake dr 2003
 ref. pt.: 007+00.309
 data collected by: alliant eng., inc.
 tmc: am, pm, noon

File Name : T.H. 65 at Moore Lake
 Site Code : 00000013
 Start Date : 8/12/2003
 Page No : 1

Groups Printed- Unshifted

Start Time	T.H. 65 Southbound					Moore Lake Dr. Westbound					T.H. 65 Northbound					Moore Lake Dr. Eastbound					Int. Total
	Left	Thru	Right	Peds	App. Total	Left	Thru	Right	Peds	App. Total	Left	Thru	Right	Peds	App. Total	Left	Thru	Right	Peds	App. Total	
06:00	5	290	3	0	298	6	3	1	0	10	0	75	8	0	83	1	5	4	0	10	401
06:15	6	344	1	0	351	10	2	2	0	14	0	112	10	0	122	0	3	8	1	12	499
06:30	7	429	2	0	438	20	5	0	1	26	0	171	7	0	178	4	4	4	1	13	655
06:45	15	357	3	0	375	20	7	4	0	31	1	162	15	0	178	2	6	8	0	16	600
Total	33	1420	9	0	1462	56	17	7	1	81	1	520	40	0	561	7	18	24	2	51	2155
07:00	12	511	10	0	533	18	10	1	1	30	1	163	13	0	177	2	6	6	0	14	754
07:15	12	460	3	0	475	18	13	1	0	32	2	188	17	0	207	2	6	8	1	17	731
07:30	17	451	8	0	476	22	12	4	0	38	3	259	15	0	277	5	3	11	1	20	811
07:45	22	372	2	0	396	23	22	5	0	50	6	244	20	0	270	6	9	6	3	24	740
Total	63	1794	23	0	1880	81	57	11	1	150	12	854	65	0	931	15	24	31	5	75	3036
08:00	18	310	4	0	332	22	8	3	0	33	2	231	22	0	255	2	3	4	1	10	630
08:15	15	295	3	0	313	15	8	8	0	31	6	185	22	2	215	3	5	3	0	11	570
08:30	9	297	11	0	317	13	10	2	0	25	3	201	24	0	228	6	9	5	2	22	592
08:45	21	243	12	0	276	16	21	7	1	45	8	187	26	2	223	4	9	5	3	21	565
Total	63	1145	30	0	1238	66	47	20	1	134	19	804	94	4	921	15	26	17	6	64	2357
11:00	14	198	2	0	214	33	10	15	0	58	4	243	22	0	269	7	21	7	2	37	578
11:15	22	227	5	0	254	29	8	12	2	51	15	267	55	0	337	8	10	5	0	23	665
11:30	23	214	4	0	241	45	19	17	0	81	6	200	38	0	244	10	22	2	0	34	600
11:45	29	228	7	0	264	42	13	16	2	73	5	219	40	0	264	13	18	0	1	32	633
Total	88	867	18	0	973	149	50	60	4	263	30	929	155	0	1114	38	71	14	3	126	2476
12:00	16	216	8	0	240	31	18	11	0	60	9	240	46	2	297	5	9	7	4	25	622
12:15	13	249	3	0	265	52	22	14	0	88	6	250	48	0	304	8	12	3	5	28	685
12:30	34	252	5	0	291	48	18	18	0	84	7	217	52	0	276	6	24	1	1	32	683
12:45	20	219	7	0	246	49	15	14	3	81	5	230	34	0	269	5	7	5	2	19	615
Total	83	936	23	0	1042	180	73	57	3	313	27	937	180	2	1146	24	52	16	12	104	2605



MINNESOTA DEPT OF TRANSPORTATION

TRAFFIC DATA COLLECTION - METRO

File Name : T.H. 65 at Moore Lake
 Site Code : 00000013
 Start Date : 8/12/2003
 Page No : 2

Groups Printed- Unshifted

Start Time	T.H. 65 Southbound					Moore Lake Dr. Westbound					T.H. 65 Northbound					Moore Lake Dr. Eastbound					Int. Total
	Left	Thru	Right	Peds	App. Total	Left	Thru	Right	Peds	App. Total	Left	Thru	Right	Peds	App. Total	Left	Thru	Right	Peds	App. Total	
15:00	26	289	3	0	318	30	14	15	1	60	7	280	25	0	312	6	74	6	0	86	776
15:15	24	194	6	0	224	28	13	16	0	57	13	341	35	0	389	10	14	1	0	25	695
15:30	20	235	3	0	258	17	12	11	0	40	7	351	26	0	384	4	16	1	0	21	703
15:45	22	232	7	0	261	30	18	11	0	59	5	396	40	0	441	8	18	0	0	26	787
Total	92	950	19	0	1061	105	57	53	1	216	32	1368	126	0	1526	28	122	8	0	158	2961
16:00	24	239	2	0	265	36	9	10	0	55	12	361	30	1	404	11	16	1	4	32	756
16:15	22	242	3	0	267	44	12	19	0	75	3	383	33	0	419	2	17	1	2	22	783
16:30	17	262	5	0	284	43	20	20	1	84	3	390	40	0	433	11	22	4	1	38	839
16:45	32	230	5	0	267	28	18	18	1	65	6	426	43	0	475	3	20	0	1	24	831
Total	95	973	15	0	1083	151	59	67	2	279	24	1560	146	1	1731	27	75	6	8	116	3209
17:00	21	285	4	0	310	62	26	20	0	108	4	412	44	0	460	6	11	0	1	18	896
17:15	28	250	8	0	286	44	21	16	0	81	8	420	50	0	478	8	22	0	4	34	879
17:30	28	235	3	0	266	59	23	15	0	97	19	393	40	0	452	10	25	1	0	36	851
17:45	23	214	6	0	243	41	25	16	0	82	3	363	41	0	407	7	11	2	0	20	752
Total	100	984	21	0	1105	206	95	67	0	368	34	1588	175	0	1797	31	69	3	5	108	3378
Grand Total	617	9069	158	0	9844	994	455	342	13	1804	179	8560	981	7	9727	185	457	119	41	802	22177
Apprch %	6.3	92.1	1.6	0		55.1	25.2	19	0.7		1.8	88	10.1	0.1		23.1	57	14.8	5.1		
Total %	2.8	40.9	0.7	0	44.4	4.5	2.1	1.5	0.1	8.1	0.8	38.6	4.4	0	43.9	0.8	2.1	0.5	0.2	3.6	



MINNESOTA DEPT OF TRANSPORTATION

TRAFFIC DATA COLLECTION - METRO

File Name : T.H. 65 at Moore Lake
 Site Code : 0000013
 Start Date : 8/12/2003
 Page No : 3

Start Time	T.H. 65 Southbound					Moore Lake Dr. Westbound					T.H. 65 Northbound					Moore Lake Dr. Eastbound					Int. Total
	Left	Thru	Right	Peds	App. Total	Left	Thru	Right	Peds	App. Total	Left	Thru	Right	Peds	App. Total	Left	Thru	Right	Peds	App. Total	
Peak Hour Analysis From 06:00 to 08:45 - Peak 1 of 1																					
Peak Hour for Entire Intersection Begins at 07:00																					
07:00	12	511	10	0	533	18	10	1	1	30	1	163	13	0	177	2	6	6	0	14	754
07:15	12	460	3	0	475	18	13	1	0	32	2	188	17	0	207	2	6	8	1	17	731
07:30	17	451	8	0	476	22	12	4	0	38	3	259	15	0	277	5	3	11	1	20	811
07:45	22	372	2	0	396	23	22	5	0	50	6	244	20	0	270	6	9	6	3	24	740
Total Volume	63	1794	23	0	1880	81	57	11	1	150	12	854	65	0	931	15	24	31	5	75	3036
% App. Total	3.4	95.4	1.2	0		54	38	7.3	0.7		1.3	91.7	7	0		20	32	41.3	6.7		
PHF	.716	.878	.575	.000	.882	.880	.648	.550	.250	.750	.500	.824	.813	.000	.840	.625	.667	.705	.417	.781	.936

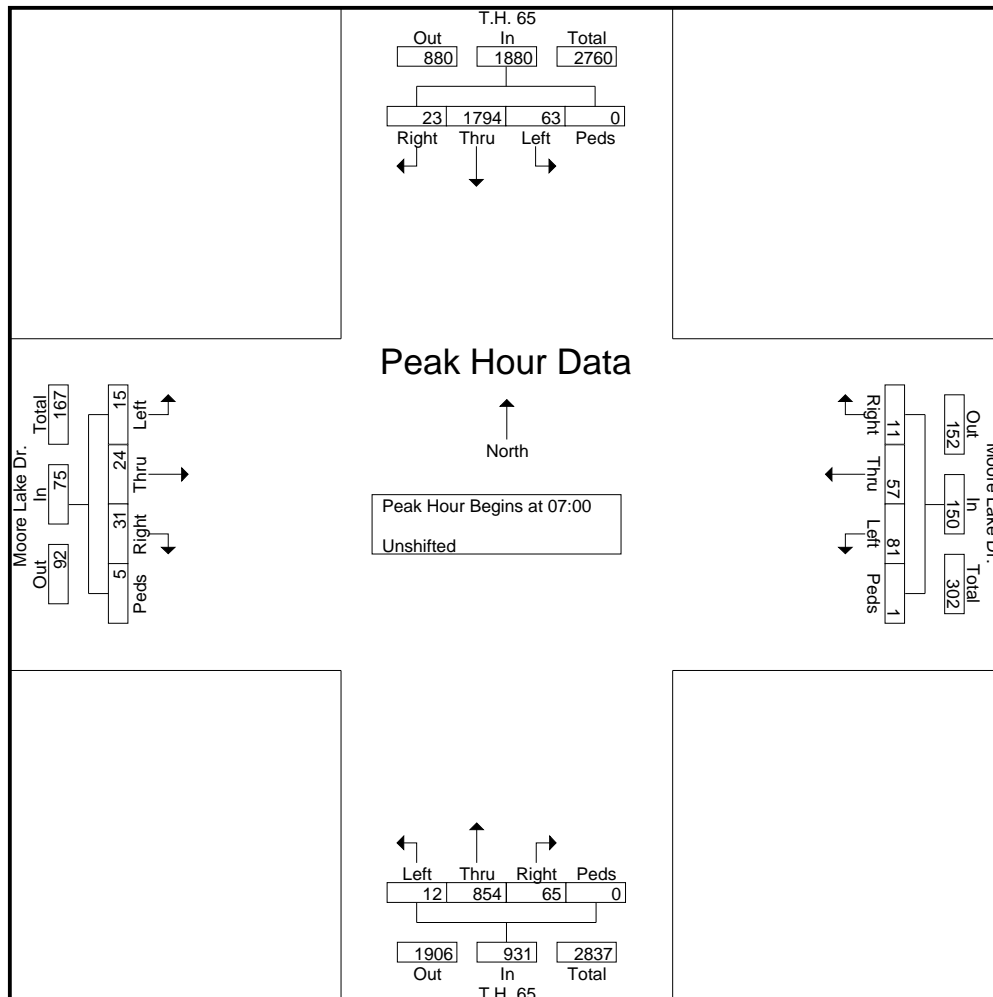



MINNESOTA DEPT OF TRANSPORTATION

TRAFFIC DATA COLLECTION - METRO

File Name : T.H. 65 at Moore Lake
 Site Code : 0000013
 Start Date : 8/12/2003
 Page No : 4

Start Time	T.H. 65 Southbound					Moore Lake Dr. Westbound					T.H. 65 Northbound					Moore Lake Dr. Eastbound					Int. Total
	Left	Thru	Right	Peds	App. Total	Left	Thru	Right	Peds	App. Total	Left	Thru	Right	Peds	App. Total	Left	Thru	Right	Peds	App. Total	
Peak Hour Analysis From 11:00 to 12:45 - Peak 1 of 1																					
Peak Hour for Entire Intersection Begins at 11:45																					
11:45	29	228	7	0	264	42	13	16	2	73	5	219	40	0	264	13	18	0	1	32	633
12:00	16	216	8	0	240	31	18	11	0	60	9	240	46	2	297	5	9	7	4	25	622
12:15	13	249	3	0	265	52	22	14	0	88	6	250	48	0	304	8	12	3	5	28	685
12:30	34	252	5	0	291	48	18	18	0	84	7	217	52	0	276	6	24	1	1	32	683
Total Volume	92	945	23	0	1060	173	71	59	2	305	27	926	186	2	1141	32	63	11	11	117	2623
% App. Total	8.7	89.2	2.2	0		56.7	23.3	19.3	0.7		2.4	81.2	16.3	0.2		27.4	53.8	9.4	9.4		
PHF	.676	.938	.719	.000	.911	.832	.807	.819	.250	.866	.750	.926	.894	.250	.938	.615	.656	.393	.550	.914	.957

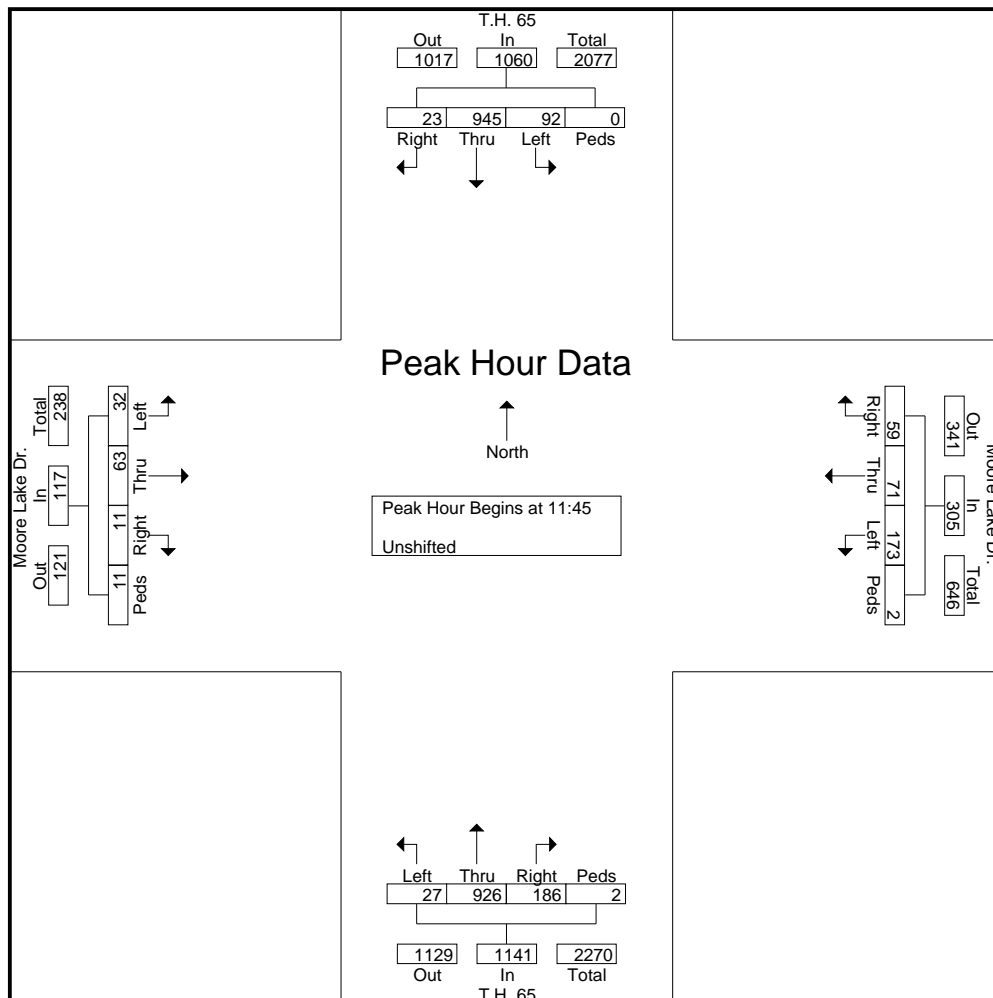



MINNESOTA DEPT OF TRANSPORTATION

TRAFFIC DATA COLLECTION - METRO

File Name : T.H. 65 at Moore Lake
 Site Code : 0000013
 Start Date : 8/12/2003
 Page No : 5

Start Time	T.H. 65 Southbound					Moore Lake Dr. Westbound					T.H. 65 Northbound					Moore Lake Dr. Eastbound					Int. Total
	Left	Thru	Right	Peds	App. Total	Left	Thru	Right	Peds	App. Total	Left	Thru	Right	Peds	App. Total	Left	Thru	Right	Peds	App. Total	
Peak Hour Analysis From 15:00 to 17:45 - Peak 1 of 1																					
Peak Hour for Entire Intersection Begins at 16:45																					
16:45	32	230	5	0	267	28	18	18	1	65	6	426	43	0	475	3	20	0	1	24	831
17:00	21	285	4	0	310	62	26	20	0	108	4	412	44	0	460	6	11	0	1	18	896
17:15	28	250	8	0	286	44	21	16	0	81	8	420	50	0	478	8	22	0	4	34	879
17:30	28	235	3	0	266	59	23	15	0	97	19	393	40	0	452	10	25	1	0	36	851
Total Volume	109	1000	20	0	1129	193	88	69	1	351	37	1651	177	0	1865	27	78	1	6	112	3457
% App. Total	9.7	88.6	1.8	0		55	25.1	19.7	0.3		2	88.5	9.5	0		24.1	69.6	0.9	5.4		
PHF	.852	.877	.625	.000	.910	.778	.846	.863	.250	.813	.487	.969	.885	.000	.975	.675	.780	.250	.375	.778	.965

