



# MINNESOTA DEPT OF TRANSPORTATION

## TRAFFIC DATA COLLECTION - METRO

loc: th 65 @ i-694 south ramp 2003  
 ref pt: 006+00.356  
 data collected by: alliant eng  
 tmc: am noon pm

File Name : T.H. 65 at I-694 South  
 Site Code : 00000010  
 Start Date : 8/7/2003  
 Page No : 1

**Groups Printed- Unshifted**

Start Time	T.H. 65 Southbound					I-694 S Ramps Westbound					T.H. 65 Northbound					I-694 S Ramps Eastbound					Int. Total
	Left	Thru	Right	Peds	App. Total	Left	Thru	Right	Peds	App. Total	Left	Thru	Right	Peds	App. Total	Left	Thru	Right	Peds	App. Total	
06:00	0	116	43	0	159	0	0	0	0	0	0	77	5	0	82	77	0	27	0	104	345
06:15	0	138	61	0	199	0	0	0	0	0	0	71	11	0	82	101	0	36	0	137	418
06:30	0	196	95	0	291	0	0	0	0	0	0	94	3	0	97	127	0	39	0	166	554
06:45	0	195	86	0	281	0	0	0	0	0	0	102	3	0	105	153	0	58	0	211	597
Total	0	645	285	0	930	0	0	0	0	0	0	344	22	0	366	458	0	160	0	618	1914
07:00	0	220	63	0	283	0	0	0	0	0	0	145	6	0	151	110	0	34	2	146	580
07:15	0	300	98	0	398	0	0	0	0	0	0	135	7	0	142	169	0	58	0	227	767
07:30	0	244	110	0	354	0	0	0	0	0	0	126	11	0	137	175	0	56	0	231	722
07:45	0	242	85	0	327	0	0	0	0	0	0	99	8	0	107	270	0	45	2	317	751
Total	0	1006	356	0	1362	0	0	0	0	0	0	505	32	0	537	724	0	193	4	921	2820
08:00	0	160	78	0	238	0	0	0	0	0	0	112	10	0	122	174	0	39	0	213	573
08:15	0	180	73	0	253	0	0	0	0	0	0	155	15	1	171	218	0	49	3	270	694
08:30	0	165	71	0	236	0	0	0	0	0	0	170	12	0	182	177	0	70	0	247	665
08:45	0	217	70	0	287	0	0	0	0	0	0	153	16	0	169	162	1	58	0	221	677
Total	0	722	292	0	1014	0	0	0	0	0	0	590	53	1	644	731	1	216	3	951	2609
11:00	0	213	77	0	290	0	0	0	0	0	0	215	27	0	242	145	1	45	0	191	723
11:15	0	228	67	0	295	0	0	0	0	0	0	255	22	0	277	169	0	88	0	257	829
11:30	0	288	106	0	394	0	0	0	0	0	0	257	20	0	277	156	1	97	0	254	925
11:45	0	250	92	0	342	0	0	0	0	0	1	236	25	1	263	170	0	81	0	251	856
Total	0	979	342	0	1321	0	0	0	0	0	1	963	94	1	1059	640	2	311	0	953	3333
12:00	0	270	85	0	355	0	0	0	0	0	0	281	23	0	304	161	5	83	0	249	908
12:15	0	204	84	0	288	0	0	0	0	0	0	279	14	2	295	138	0	120	0	258	841
12:30	0	248	85	0	333	0	0	0	0	0	0	269	12	1	282	125	0	91	0	216	831
12:45	0	212	86	0	298	0	0	0	0	0	0	298	22	4	324	151	0	56	0	207	829
Total	0	934	340	0	1274	0	0	0	0	0	0	1127	71	7	1205	575	5	350	0	930	3409



# MINNESOTA DEPT OF TRANSPORTATION

## TRAFFIC DATA COLLECTION - METRO

File Name : T.H. 65 at I-694 South  
 Site Code : 00000010  
 Start Date : 8/7/2003  
 Page No : 2

**Groups Printed- Unshifted**

Start Time	T.H. 65 Southbound					I-694 S Ramps Westbound					T.H. 65 Northbound					I-694 S Ramps Eastbound					Int. Total
	Left	Thru	Right	Peds	App. Total	Left	Thru	Right	Peds	App. Total	Left	Thru	Right	Peds	App. Total	Left	Thru	Right	Peds	App. Total	
15:00	0	239	74	0	313	0	0	0	0	0	1	338	38	0	377	265	0	33	0	298	988
15:15	0	243	92	0	335	0	0	0	0	0	0	370	22	0	392	243	0	58	0	301	1028
15:30	0	190	85	0	275	0	0	0	0	0	0	368	23	0	391	250	4	106	0	360	1026
15:45	0	220	80	0	300	0	0	0	0	0	0	341	20	0	361	222	2	75	0	299	960
<b>Total</b>	0	892	331	0	1223	0	0	0	0	0	1	1417	103	0	1521	980	6	272	0	1258	4002
16:00	0	229	95	1	325	0	0	0	0	0	6	318	24	0	348	267	2	101	2	372	1045
16:15	0	221	98	0	319	0	0	0	0	0	34	354	25	0	413	214	2	51	0	267	999
16:30	0	245	84	0	329	0	0	0	0	0	0	345	14	1	360	260	4	71	5	340	1029
16:45	0	230	86	0	316	0	0	0	0	0	0	356	14	0	370	242	2	101	0	345	1031
<b>Total</b>	0	925	363	1	1289	0	0	0	0	0	40	1373	77	1	1491	983	10	324	7	1324	4104
17:00	0	221	100	0	321	0	0	0	0	0	0	351	20	0	371	248	7	67	8	330	1022
17:15	0	234	97	0	331	0	0	0	0	0	0	351	21	0	372	264	7	79	0	350	1053
17:30	0	207	78	0	285	0	0	0	0	0	0	340	7	0	347	285	3	104	0	392	1024
17:45	0	205	64	0	269	0	0	0	0	0	0	340	27	0	367	256	31	93	0	380	1016
<b>Total</b>	0	867	339	0	1206	0	0	0	0	0	0	1382	75	0	1457	1053	48	343	8	1452	4115
Grand Total	0	6970	2648	1	9619	0	0	0	0	0	42	7701	527	10	8280	6144	72	2169	22	8407	26306
Apprch %	0	72.5	27.5	0		0	0	0	0		0.5	93	6.4	0.1		73.1	0.9	25.8	0.3		
Total %	0	26.5	10.1	0	36.6	0	0	0	0		0.2	29.3	2	0	31.5	23.4	0.3	8.2	0.1	32	



# MINNESOTA DEPT OF TRANSPORTATION

## TRAFFIC DATA COLLECTION - METRO

File Name : T.H. 65 at I-694 South  
 Site Code : 00000010  
 Start Date : 8/7/2003  
 Page No : 3

Start Time	T.H. 65 Southbound					I-694 S Ramps Westbound					T.H. 65 Northbound					I-694 S Ramps Eastbound					Int. Total
	Left	Thru	Right	Peds	App. Total	Left	Thru	Right	Peds	App. Total	Left	Thru	Right	Peds	App. Total	Left	Thru	Right	Peds	App. Total	
Peak Hour Analysis From 06:00 to 09:45 - Peak 1 of 1																					
Peak Hour for Entire Intersection Begins at 07:00																					
07:00	0	220	63	0	283	0	0	0	0	0	0	145	6	0	151	110	0	34	2	146	580
07:15	0	300	98	0	398	0	0	0	0	0	0	135	7	0	142	169	0	58	0	227	767
07:30	0	244	110	0	354	0	0	0	0	0	0	126	11	0	137	175	0	56	0	231	722
07:45	0	242	85	0	327	0	0	0	0	0	0	99	8	0	107	270	0	45	2	317	751
Total Volume	0	1006	356	0	1362	0	0	0	0	0	0	505	32	0	537	724	0	193	4	921	2820
% App. Total	0	73.9	26.1	0		0	0	0	0		0	94	6	0		78.6	0	21	0.4		
PHF	.000	.838	.809	.000	.856	.000	.000	.000	.000	.000	.000	.871	.727	.000	.889	.670	.000	.832	.500	.726	.919

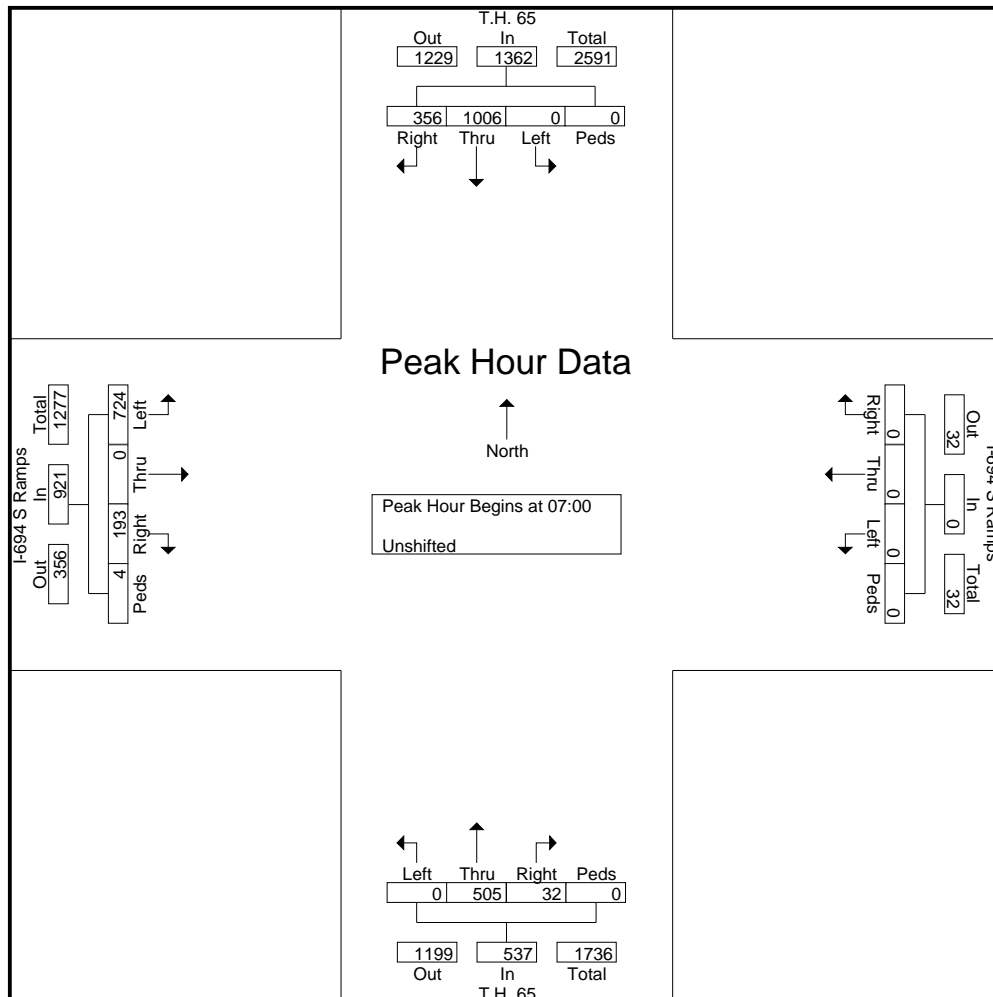



# MINNESOTA DEPT OF TRANSPORTATION

## TRAFFIC DATA COLLECTION - METRO

File Name : T.H. 65 at I-694 South  
 Site Code : 00000010  
 Start Date : 8/7/2003  
 Page No : 4

Start Time	T.H. 65 Southbound					I-694 S Ramps Westbound					T.H. 65 Northbound					I-694 S Ramps Eastbound					Int. Total
	Left	Thru	Right	Peds	App. Total	Left	Thru	Right	Peds	App. Total	Left	Thru	Right	Peds	App. Total	Left	Thru	Right	Peds	App. Total	
Peak Hour Analysis From 10:00 to 13:45 - Peak 1 of 1																					
Peak Hour for Entire Intersection Begins at 11:30																					
11:30	0	<b>288</b>	<b>106</b>	0	<b>394</b>	0	0	0	0	0	0	257	20	0	277	156	1	97	0	254	<b>925</b>
11:45	0	250	92	0	342	0	0	0	0	0	<b>1</b>	236	<b>25</b>	1	263	<b>170</b>	0	81	0	251	856
12:00	0	270	85	0	355	0	0	0	0	0	0	<b>281</b>	23	0	<b>304</b>	161	<b>5</b>	83	0	249	908
12:15	0	204	84	0	288	0	0	0	0	0	0	279	14	<b>2</b>	295	138	0	<b>120</b>	0	<b>258</b>	841
Total Volume	0	1012	367	0	1379	0	0	0	0	0	1	1053	82	3	1139	625	6	381	0	1012	3530
% App. Total	0	73.4	26.6	0		0	0	0	0		0.1	92.4	7.2	0.3		61.8	0.6	37.6	0		
PHF	.000	.878	.866	.000	.875	.000	.000	.000	.000	.000	.250	.937	.820	.375	.937	.919	.300	.794	.000	.981	.954

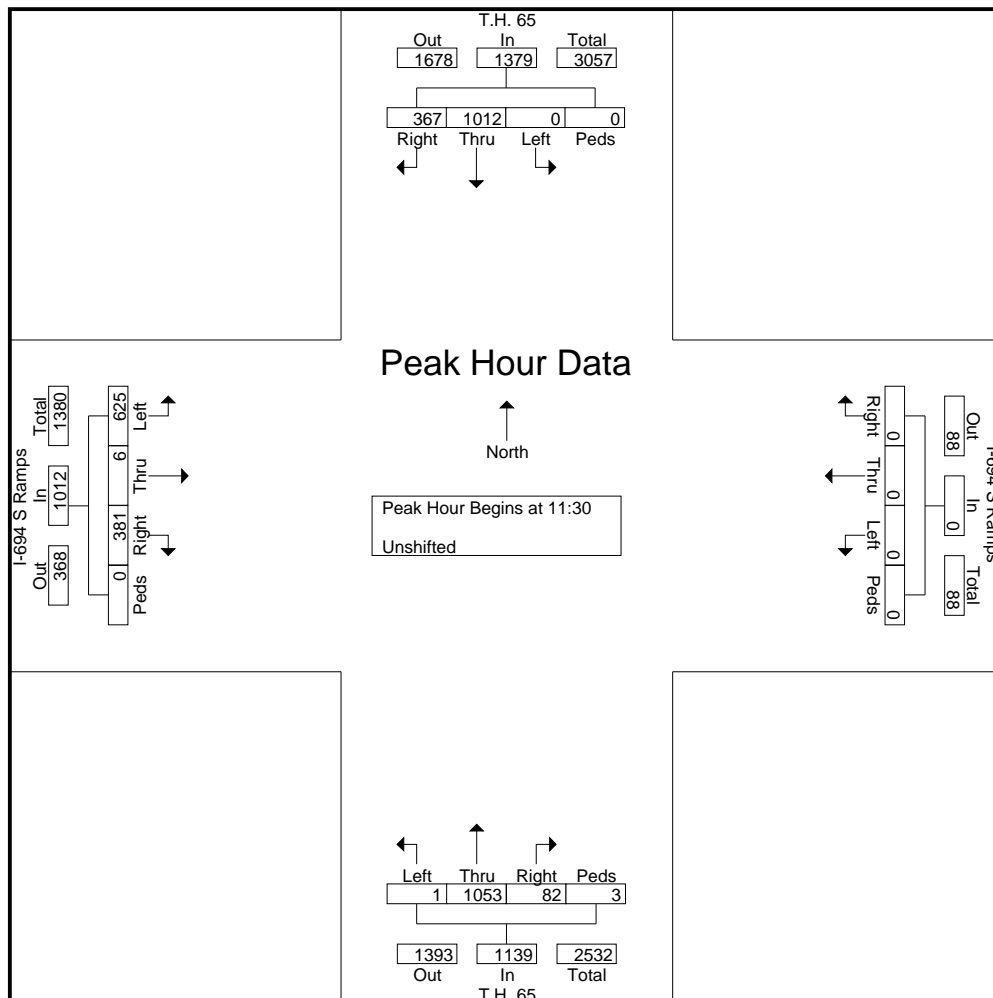



# MINNESOTA DEPT OF TRANSPORTATION

## TRAFFIC DATA COLLECTION - METRO

File Name : T.H. 65 at I-694 South  
 Site Code : 00000010  
 Start Date : 8/7/2003  
 Page No : 5

Start Time	T.H. 65 Southbound					I-694 S Ramps Westbound					T.H. 65 Northbound					I-694 S Ramps Eastbound					Int. Total
	Left	Thru	Right	Peds	App. Total	Left	Thru	Right	Peds	App. Total	Left	Thru	Right	Peds	App. Total	Left	Thru	Right	Peds	App. Total	
Peak Hour Analysis From 14:00 to 17:45 - Peak 1 of 1																					
Peak Hour for Entire Intersection Begins at 16:30																					
16:30	0	245	84	0	329	0	0	0	0	0	0	345	14	1	360	260	4	71	5	340	1029
16:45	0	230	86	0	316	0	0	0	0	0	0	356	14	0	370	242	2	101	0	345	1031
17:00	0	221	100	0	321	0	0	0	0	0	0	351	20	0	371	248	7	67	8	330	1022
17:15	0	234	97	0	331	0	0	0	0	0	0	351	21	0	372	264	7	79	0	350	1053
Total Volume	0	930	367	0	1297	0	0	0	0	0	0	1403	69	1	1473	1014	20	318	13	1365	4135
% App. Total	0	71.7	28.3	0		0	0	0	0		0	95.2	4.7	0.1		74.3	1.5	23.3	1		
PHF	.000	.949	.918	.000	.980	.000	.000	.000	.000	.000	.000	.985	.821	.250	.990	.960	.714	.787	.406	.975	.982

