



Minnesota Dept. of Transportation

Traffic Data Collection -Metro

TH-65 / CENTRAL AVE NE AT 45TH AVE NE
 Ref.Pt; 005.135
 Jamar # T-2638 CAH
 TURN MOVEMENT COUNT

File Name : TH-65 AT 45TH AVE NE 2012
 Site Code : 005.135
 Start Date : 3/14/2012
 Page No : 1

Groups Printed- Unshifted

| Start Time | TH-65 / CENTRAL AVE NE Southbound | | | | 45TH AVE NE Westbound | | | | TH-65 / CENTRAL AVE NE Northbound | | | | 45TH AVE NE Eastbound | | | | Int. Total |
|--------------------|--------------------------------------|-------------|------------|------------|--------------------------|-------------|-------------|------------|--------------------------------------|-------------|------------|------------|--------------------------|-------------|-------------|------------|--------------|
| | Right | Thru | Left | Peds | Right | Thru | Left | Peds | Right | Thru | Left | Peds | Right | Thru | Left | Peds | |
| 06:00 | 0 | 74 | 1 | 1 | 0 | 2 | 1 | 0 | 0 | 27 | 2 | 1 | 2 | 1 | 0 | 0 | 112 |
| 06:15 | 1 | 113 | 0 | 0 | 4 | 0 | 2 | 0 | 0 | 76 | 3 | 1 | 4 | 0 | 4 | 1 | 209 |
| 06:30 | 1 | 131 | 0 | 0 | 2 | 1 | 4 | 0 | 1 | 85 | 1 | 0 | 2 | 1 | 3 | 0 | 232 |
| 06:45 | 2 | 136 | 1 | 2 | 0 | 2 | 1 | 0 | 1 | 50 | 0 | 0 | 5 | 1 | 3 | 0 | 204 |
| Total | 4 | 454 | 2 | 3 | 6 | 5 | 8 | 0 | 2 | 238 | 6 | 2 | 13 | 3 | 10 | 1 | 757 |
| 07:00 | 2 | 143 | 1 | 2 | 5 | 2 | 5 | 0 | 0 | 76 | 4 | 0 | 4 | 3 | 2 | 3 | 252 |
| 07:15 | 3 | 203 | 0 | 1 | 1 | 3 | 2 | 0 | 1 | 97 | 0 | 0 | 7 | 2 | 3 | 0 | 323 |
| 07:30 | 5 | 211 | 1 | 3 | 4 | 3 | 2 | 3 | 4 | 128 | 4 | 0 | 2 | 0 | 9 | 0 | 379 |
| 07:45 | 5 | 221 | 3 | 2 | 6 | 0 | 3 | 0 | 3 | 128 | 4 | 5 | 4 | 1 | 5 | 0 | 390 |
| Total | 15 | 778 | 5 | 8 | 16 | 8 | 12 | 3 | 8 | 429 | 12 | 5 | 17 | 6 | 19 | 3 | 1344 |
| 08:00 | 8 | 206 | 3 | 0 | 0 | 4 | 5 | 1 | 3 | 148 | 4 | 1 | 1 | 0 | 10 | 0 | 394 |
| 08:15 | 4 | 163 | 3 | 2 | 3 | 3 | 2 | 1 | 3 | 130 | 4 | 1 | 5 | 2 | 4 | 0 | 330 |
| 08:30 | 1 | 159 | 4 | 0 | 4 | 2 | 4 | 0 | 1 | 140 | 8 | 1 | 3 | 2 | 3 | 1 | 333 |
| 08:45 | 5 | 154 | 7 | 2 | 5 | 1 | 1 | 1 | 0 | 123 | 3 | 0 | 3 | 0 | 6 | 3 | 314 |
| Total | 18 | 682 | 17 | 4 | 12 | 10 | 12 | 3 | 7 | 541 | 19 | 3 | 12 | 4 | 23 | 4 | 1371 |
| *** BREAK *** | | | | | | | | | | | | | | | | | |
| 15:00 | 11 | 173 | 6 | 2 | 7 | 1 | 4 | 0 | 8 | 228 | 18 | 0 | 6 | 0 | 23 | 0 | 487 |
| 15:15 | 15 | 189 | 7 | 10 | 2 | 2 | 4 | 2 | 5 | 252 | 8 | 1 | 6 | 3 | 18 | 1 | 525 |
| 15:30 | 13 | 213 | 7 | 9 | 9 | 6 | 1 | 2 | 6 | 273 | 20 | 6 | 12 | 6 | 18 | 1 | 602 |
| 15:45 | 12 | 210 | 6 | 3 | 2 | 4 | 2 | 7 | 6 | 299 | 15 | 5 | 7 | 1 | 20 | 3 | 602 |
| Total | 51 | 785 | 26 | 24 | 20 | 13 | 11 | 11 | 25 | 1052 | 61 | 12 | 31 | 10 | 79 | 5 | 2216 |
| 16:00 | 18 | 199 | 14 | 8 | 4 | 9 | 5 | 5 | 7 | 260 | 15 | 2 | 9 | 4 | 20 | 1 | 580 |
| 16:15 | 11 | 206 | 7 | 1 | 2 | 3 | 4 | 3 | 3 | 300 | 17 | 6 | 7 | 1 | 24 | 2 | 597 |
| 16:30 | 17 | 223 | 6 | 8 | 8 | 1 | 3 | 2 | 4 | 273 | 15 | 6 | 7 | 1 | 15 | 0 | 589 |
| 16:45 | 20 | 216 | 7 | 11 | 4 | 5 | 5 | 1 | 6 | 274 | 14 | 1 | 17 | 13 | 35 | 0 | 629 |
| Total | 66 | 844 | 34 | 28 | 18 | 18 | 17 | 11 | 20 | 1107 | 61 | 15 | 40 | 19 | 94 | 3 | 2395 |
| 17:00 | 11 | 215 | 6 | 1 | 6 | 6 | 3 | 1 | 6 | 300 | 19 | 1 | 10 | 2 | 18 | 0 | 605 |
| 17:15 | 13 | 244 | 3 | 10 | 3 | 1 | 2 | 5 | 6 | 272 | 25 | 14 | 8 | 7 | 26 | 0 | 639 |
| 17:30 | 9 | 191 | 7 | 0 | 5 | 5 | 6 | 2 | 7 | 270 | 16 | 7 | 16 | 3 | 20 | 0 | 564 |
| 17:45 | 13 | 185 | 9 | 9 | 7 | 6 | 4 | 0 | 8 | 275 | 22 | 5 | 10 | 2 | 25 | 1 | 581 |
| Total | 46 | 835 | 25 | 20 | 21 | 18 | 15 | 8 | 27 | 1117 | 82 | 27 | 44 | 14 | 89 | 1 | 2389 |
| Grand Total | 200 | 4378 | 109 | 87 | 93 | 72 | 75 | 36 | 89 | 4484 | 241 | 64 | 157 | 56 | 314 | 17 | 10472 |
| Apprch % | 4.2 | 91.7 | 2.3 | 1.8 | 33.7 | 26.1 | 27.2 | 13 | 1.8 | 91.9 | 4.9 | 1.3 | 28.9 | 10.3 | 57.7 | 3.1 | |
| Total % | 1.9 | 41.8 | 1 | 0.8 | 0.9 | 0.7 | 0.7 | 0.3 | 0.8 | 42.8 | 2.3 | 0.6 | 1.5 | 0.5 | 3 | 0.2 | |



Minnesota Dept. of Transportation

Traffic Data Collection -Metro

TH-65 / CENTRAL AVE NE AT 45TH AVE NE
 Ref.Pt; 005.135
 Jamar # T-2638 CAH
 TURN MOVEMENT COUNT

File Name : TH-65 AT 45TH AVE NE 2012
 Site Code : 005.135
 Start Date : 3/14/2012
 Page No : 2

| Start Time | TH-65 / CENTRAL AVE NE Southbound | | | | | 45TH AVE NE Westbound | | | | | TH-65 / CENTRAL AVE NE Northbound | | | | | 45TH AVE NE Eastbound | | | | | Int. Total |
|--|-----------------------------------|------|------|------|------------|-----------------------|------|------|------|------------|-----------------------------------|------|-------|------|------------|-----------------------|------|------|------|------------|------------|
| | Right | Thru | Left | Peds | App. Total | Right | Thru | Left | Peds | App. Total | Right | Thru | Left | Peds | App. Total | Right | Thru | Left | Peds | App. Total | |
| Peak Hour Analysis From 06:00 to 08:45 - Peak 1 of 1 | | | | | | | | | | | | | | | | | | | | | |
| Peak Hour for Entire Intersection Begins at 07:30 | | | | | | | | | | | | | | | | | | | | | |
| 07:30 | 5 | 211 | 1 | 3 | 220 | 4 | 3 | 2 | 3 | 12 | 4 | 128 | 4 | 0 | 136 | 2 | 0 | 9 | 0 | 11 | 379 |
| 07:45 | 5 | 221 | 3 | 2 | 231 | 6 | 0 | 3 | 0 | 9 | 3 | 128 | 4 | 5 | 140 | 4 | 1 | 5 | 0 | 10 | 390 |
| 08:00 | 8 | 206 | 3 | 0 | 217 | 0 | 4 | 5 | 1 | 10 | 3 | 148 | 4 | 1 | 156 | 1 | 0 | 10 | 0 | 11 | 394 |
| 08:15 | 4 | 163 | 3 | 2 | 172 | 3 | 3 | 2 | 1 | 9 | 3 | 130 | 4 | 1 | 138 | 5 | 2 | 4 | 0 | 11 | 330 |
| Total Volume | 22 | 801 | 10 | 7 | 840 | 13 | 10 | 12 | 5 | 40 | 13 | 534 | 16 | 7 | 570 | 12 | 3 | 28 | 0 | 43 | 1493 |
| % App. Total | 2.6 | 95.4 | 1.2 | 0.8 | | 32.5 | 25 | 30 | 12.5 | | 2.3 | 93.7 | 2.8 | 1.2 | | 27.9 | 7 | 65.1 | 0 | | |
| PHF | .688 | .906 | .833 | .583 | .909 | .542 | .625 | .600 | .417 | .833 | .813 | .902 | 1.000 | | | | | | | | |

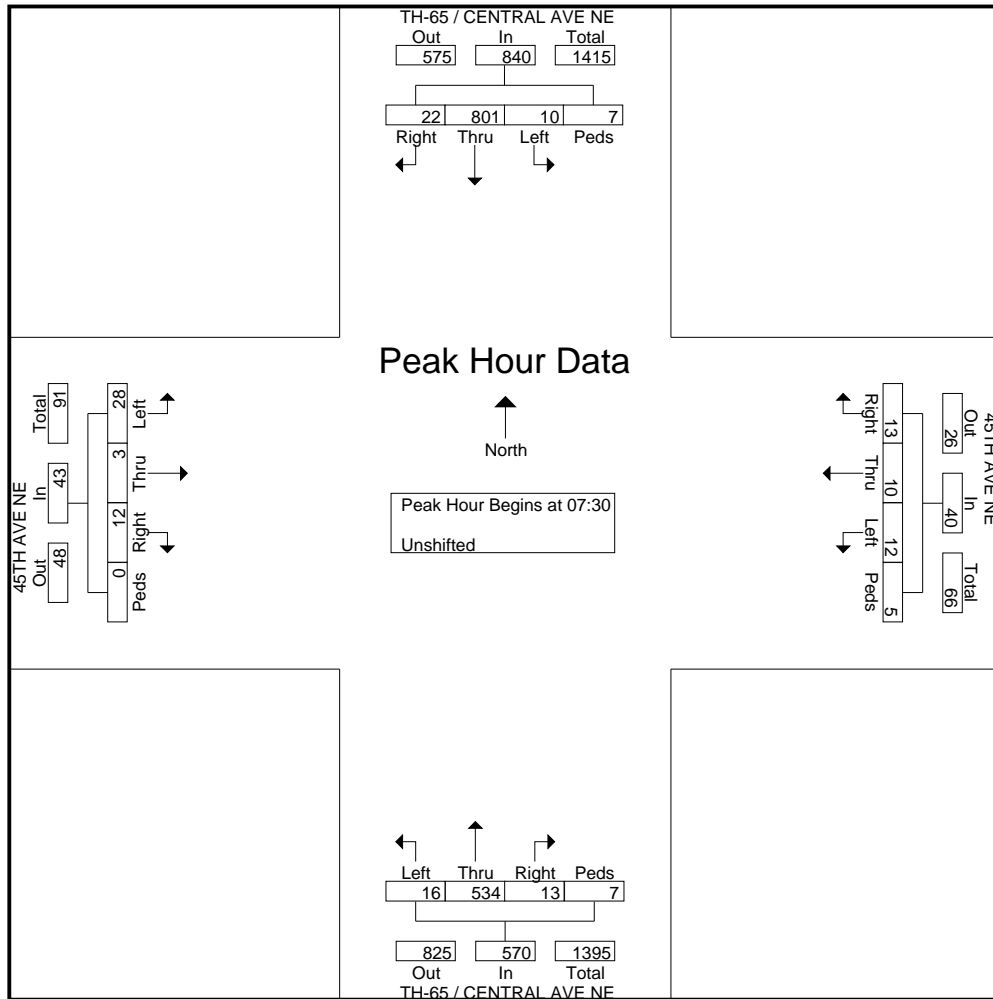



Minnesota Dept. of Transportation

Traffic Data Collection -Metro

TH-65 / CENTRAL AVE NE AT 45TH AVE NE
 Ref.Pt; 005.135
 Jamar # T-2638 CAH
 TURN MOVEMENT COUNT

File Name : TH-65 AT 45TH AVE NE 2012
 Site Code : 005.135
 Start Date : 3/14/2012
 Page No : 3

| Start Time | TH-65 / CENTRAL AVE NE Southbound | | | | | 45TH AVE NE Westbound | | | | | TH-65 / CENTRAL AVE NE Northbound | | | | | 45TH AVE NE Eastbound | | | | | Int. Total |
|--|-----------------------------------|------|------|------|------------|-----------------------|------|------|------|------------|-----------------------------------|------|------|------|------------|-----------------------|------|------|------|------------|------------|
| | Right | Thru | Left | Peds | App. Total | Right | Thru | Left | Peds | App. Total | Right | Thru | Left | Peds | App. Total | Right | Thru | Left | Peds | App. Total | |
| Peak Hour Analysis From 15:00 to 17:45 - Peak 1 of 1 | | | | | | | | | | | | | | | | | | | | | |
| Peak Hour for Entire Intersection Begins at 16:30 | | | | | | | | | | | | | | | | | | | | | |
| 16:30 | 17 | 223 | 6 | 8 | 254 | 8 | 1 | 3 | 2 | 14 | 4 | 273 | 15 | 6 | 298 | 7 | 1 | 15 | 0 | 23 | 589 |
| 16:45 | 20 | 216 | 7 | 11 | 254 | 4 | 5 | 5 | 1 | 15 | 6 | 274 | 14 | 1 | 295 | 17 | 13 | 35 | 0 | 65 | 629 |
| 17:00 | 11 | 215 | 6 | 1 | 233 | 6 | 6 | 3 | 1 | 16 | 6 | 300 | 19 | 1 | 326 | 10 | 2 | 18 | 0 | 30 | 605 |
| 17:15 | 13 | 244 | 3 | 10 | 270 | 3 | 1 | 2 | 5 | 11 | 6 | 272 | 25 | 14 | 317 | 8 | 7 | 26 | 0 | 41 | 639 |
| Total Volume | 61 | 898 | 22 | 30 | 1011 | 21 | 13 | 13 | 9 | 56 | 22 | 1119 | 73 | 22 | 1236 | 42 | 23 | 94 | 0 | 159 | 2462 |
| % App. Total | 6 | 88.8 | 2.2 | 3 | | 37.5 | 23.2 | 23.2 | 16.1 | | 1.8 | 90.5 | 5.9 | 1.8 | | 26.4 | 14.5 | 59.1 | 0 | | |
| PHF | .763 | .920 | .786 | .682 | .936 | .656 | .542 | .650 | .450 | .875 | .917 | .933 | .730 | .393 | .948 | .618 | .442 | .671 | .000 | .612 | .963 |

