



MINNESOTA DEPT OF TRANSPORTATION

TRAFFIC DATA COLLECTION - METRO

loc: th 65 @ 44th ave ne 2003
 ref pt: 005+00.011
 data collected by: alliant eng
 tmc: am noon pm

File Name : T.H. 65 at 44th
 Site Code : 00000003
 Start Date : 7/30/2003
 Page No : 1

Groups Printed- Unshifted

Start Time	T.H. 65 Southbound					44th Ave. NE Westbound					T.H. 65 Northbound					44th Ave. NE Eastbound					Int. Total
	Left	Thru	Right	Peds	App. Total	Left	Thru	Right	Peds	App. Total	Left	Thru	Right	Peds	App. Total	Left	Thru	Right	Peds	App. Total	
06:00	4	107	5	0	116	3	13	4	0	20	2	40	2	0	44	7	5	5	0	17	197
06:15	7	142	6	0	155	1	10	5	1	17	2	36	0	1	39	7	8	4	0	19	230
06:30	7	181	14	0	202	3	16	13	2	34	3	49	3	1	56	7	7	10	0	24	316
06:45	10	160	14	0	184	4	12	10	1	27	3	61	2	0	66	9	7	4	0	20	297
Total	28	590	39	0	657	11	51	32	4	98	10	186	7	2	205	30	27	23	0	80	1040
07:00	14	212	14	0	240	6	12	17	1	36	2	51	1	2	56	12	7	5	1	25	357
07:15	9	214	14	1	238	7	9	14	0	30	10	56	4	1	71	12	15	6	0	33	372
07:30	9	187	11	0	207	6	10	26	0	42	6	66	4	1	77	11	13	6	1	31	357
07:45	7	200	13	0	220	4	13	19	0	36	5	84	1	0	90	14	13	11	1	39	385
Total	39	813	52	1	905	23	44	76	1	144	23	257	10	4	294	49	48	28	3	128	1471
08:00	7	152	6	0	165	7	14	13	0	34	4	82	2	3	91	10	16	6	0	32	322
08:15	7	142	10	0	159	7	22	15	1	45	4	110	2	0	116	8	15	10	0	33	353
08:30	12	161	16	2	191	5	16	12	1	34	4	92	2	0	98	5	15	11	0	31	354
08:45	10	152	15	1	178	0	0	0	0	0	0	0	0	0	0	24	14	6	0	44	222
Total	36	607	47	3	693	19	52	40	2	113	12	284	6	3	305	47	60	33	0	140	1251
11:00	19	139	19	1	178	11	26	25	0	62	17	131	2	2	152	23	15	20	0	58	450
11:15	22	173	16	2	213	14	15	23	4	56	9	198	3	4	214	31	16	5	1	53	536
11:30	15	167	20	2	204	9	11	24	7	51	3	175	7	6	191	29	14	10	0	53	499
11:45	20	166	31	2	219	9	11	26	0	46	13	173	7	0	193	24	21	14	1	60	518
Total	76	645	86	7	814	43	63	98	11	215	42	677	19	12	750	107	66	49	2	224	2003
12:00	33	155	18	1	207	2	26	26	0	54	13	186	6	3	208	25	29	13	0	67	536
12:15	22	156	18	0	196	11	17	22	3	53	13	181	4	2	200	38	24	11	1	74	523
12:30	24	166	18	0	208	8	24	31	12	75	13	196	9	4	222	26	22	8	2	58	563
12:45	22	170	17	1	210	0	0	0	0	0	0	0	0	0	0	38	29	7	0	74	284
Total	101	647	71	2	821	21	67	79	15	182	39	563	19	9	630	127	104	39	3	273	1906



MINNESOTA DEPT OF TRANSPORTATION

TRAFFIC DATA COLLECTION - METRO

File Name : T.H. 65 at 44th
 Site Code : 00000003
 Start Date : 7/30/2003
 Page No : 2

Groups Printed- Unshifted

Start Time	T.H. 65 Southbound					44th Ave. NE Westbound					T.H. 65 Northbound					44th Ave. NE Eastbound					Int. Total
	Left	Thru	Right	Peds	App. Total	Left	Thru	Right	Peds	App. Total	Left	Thru	Right	Peds	App. Total	Left	Thru	Right	Peds	App. Total	
15:00	22	165	28	0	215	7	32	32	0	71	18	213	8	2	241	37	22	17	1	77	604
15:15	19	162	15	4	200	5	26	31	5	67	6	194	9	2	211	30	23	10	1	64	542
15:30	24	144	18	3	189	9	34	27	0	70	14	228	13	1	256	30	29	11	0	70	585
15:45	26	172	20	2	220	15	25	31	1	72	9	224	12	4	249	29	23	23	7	82	623
Total	91	643	81	9	824	36	117	121	6	280	47	859	42	9	957	126	97	61	9	293	2354
16:00	12	203	23	5	243	13	30	36	3	82	12	244	15	2	273	28	34	14	0	76	674
16:15	11	177	26	3	217	12	21	27	7	67	12	239	14	2	267	26	32	17	0	75	626
16:30	16	205	25	1	247	11	21	35	0	67	20	275	9	2	306	17	36	14	2	69	689
16:45	22	156	26	0	204	11	24	37	16	88	16	281	11	0	308	30	36	12	1	79	679
Total	61	741	100	9	911	47	96	135	26	304	60	1039	49	6	1154	101	138	57	3	299	2668
17:00	16	186	22	2	226	9	30	35	1	75	15	249	14	2	280	25	25	14	0	64	645
17:15	11	189	32	0	232	7	25	28	4	64	14	285	7	1	307	27	25	14	1	67	670
17:30	15	148	25	1	189	4	19	26	0	49	13	230	4	1	248	41	29	18	1	89	575
17:45	15	190	27	0	232	0	1	0	0	1	0	0	0	0	0	28	18	17	0	63	296
Total	57	713	106	3	879	20	75	89	5	189	42	764	25	4	835	121	97	63	2	283	2186
Grand Total	489	5399	582	34	6504	220	565	670	70	1525	275	4629	177	49	5130	708	637	353	22	1720	14879
Apprch %	7.5	83	8.9	0.5		14.4	37	43.9	4.6		5.4	90.2	3.5	1		41.2	37	20.5	1.3		
Total %	3.3	36.3	3.9	0.2	43.7	1.5	3.8	4.5	0.5	10.2	1.8	31.1	1.2	0.3	34.5	4.8	4.3	2.4	0.1	11.6	



MINNESOTA DEPT OF TRANSPORTATION

TRAFFIC DATA COLLECTION - METRO

File Name : T.H. 65 at 44th
 Site Code : 00000003
 Start Date : 7/30/2003
 Page No : 3

Start Time	T.H. 65 Southbound					44th Ave. NE Westbound					T.H. 65 Northbound					44th Ave. NE Eastbound					Int. Total
	Left	Thru	Right	Peds	App. Total	Left	Thru	Right	Peds	App. Total	Left	Thru	Right	Peds	App. Total	Left	Thru	Right	Peds	App. Total	
Peak Hour Analysis From 06:00 to 09:45 - Peak 1 of 1																					
Peak Hour for Entire Intersection Begins at 07:00																					
07:00	14	212	14	0	240	6	12	17	1	36	2	51	1	2	56	12	7	5	1	25	357
07:15	9	214	14	1	238	7	9	14	0	30	10	56	4	1	71	12	15	6	0	33	372
07:30	9	187	11	0	207	6	10	26	0	42	6	66	4	1	77	11	13	6	1	31	357
07:45	7	200	13	0	220	4	13	19	0	36	5	84	1	0	90	14	13	11	1	39	385
Total Volume	39	813	52	1	905	23	44	76	1	144	23	257	10	4	294	49	48	28	3	128	1471
% App. Total	4.3	89.8	5.7	0.1		16	30.6	52.8	0.7		7.8	87.4	3.4	1.4		38.3	37.5	21.9	2.3		
PHF	.696	.950	.929	.250	.943	.821	.846	.731	.250	.857	.575	.765	.625	.500	.817	.875	.800	.636	.750	.821	.955

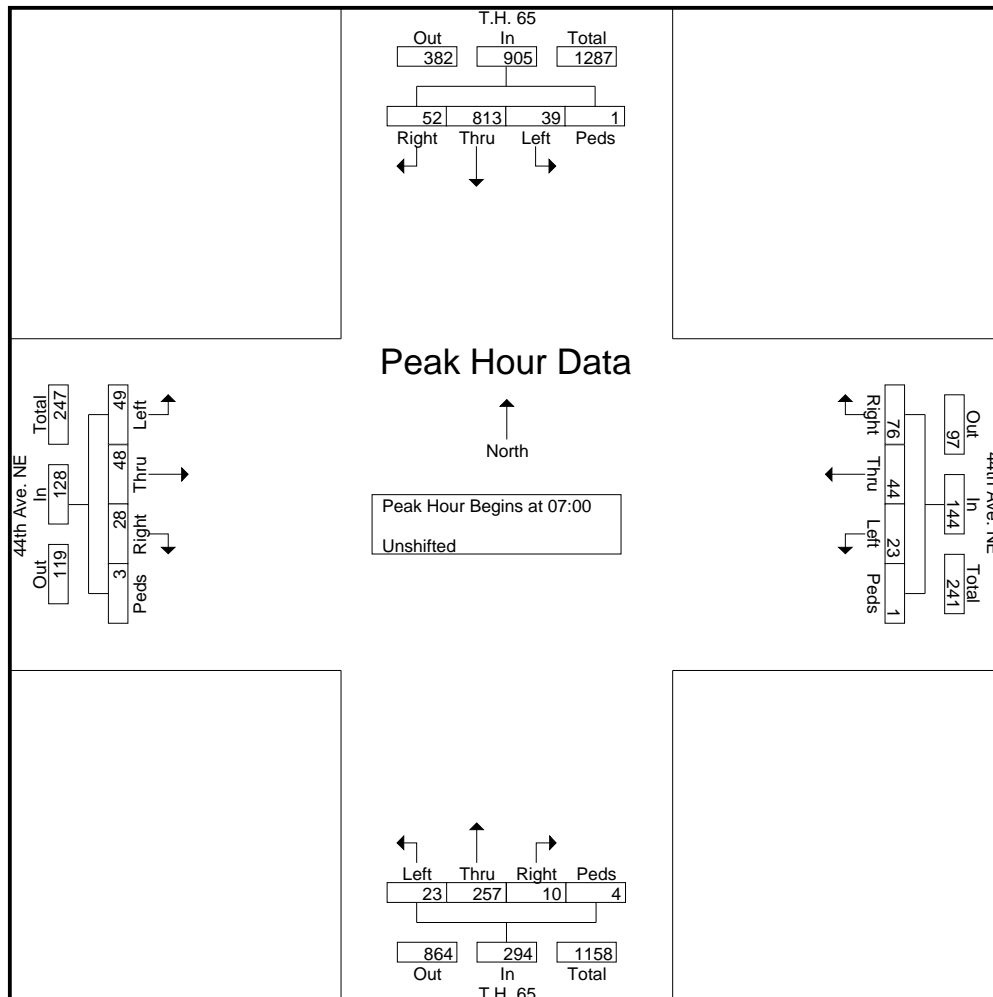



MINNESOTA DEPT OF TRANSPORTATION

TRAFFIC DATA COLLECTION - METRO

File Name : T.H. 65 at 44th
 Site Code : 00000003
 Start Date : 7/30/2003
 Page No : 4

Start Time	T.H. 65 Southbound					44th Ave. NE Westbound					T.H. 65 Northbound					44th Ave. NE Eastbound					Int. Total
	Left	Thru	Right	Peds	App. Total	Left	Thru	Right	Peds	App. Total	Left	Thru	Right	Peds	App. Total	Left	Thru	Right	Peds	App. Total	
Peak Hour Analysis From 10:00 to 13:45 - Peak 1 of 1																					
Peak Hour for Entire Intersection Begins at 11:45																					
11:45	20	166	31	2	219	9	11	26	0	46	13	173	7	0	193	24	21	14	1	60	518
12:00	33	155	18	1	207	2	26	26	0	54	13	186	6	3	208	25	29	13	0	67	536
12:15	22	156	18	0	196	11	17	22	3	53	13	181	4	2	200	38	24	11	1	74	523
12:30	24	166	18	0	208	8	24	31	12	75	13	196	9	4	222	26	22	8	2	58	563
Total Volume	99	643	85	3	830	30	78	105	15	228	52	736	26	9	823	113	96	46	4	259	2140
% App. Total	11.9	77.5	10.2	0.4		13.2	34.2	46.1	6.6		6.3	89.4	3.2	1.1		43.6	37.1	17.8	1.5		
PHF	.750	.968	.685	.375	.947	.682	.750	.847	.313	.760	1.000	.939	.722	.563	.927	.743	.828	.821	.500	.875	.950

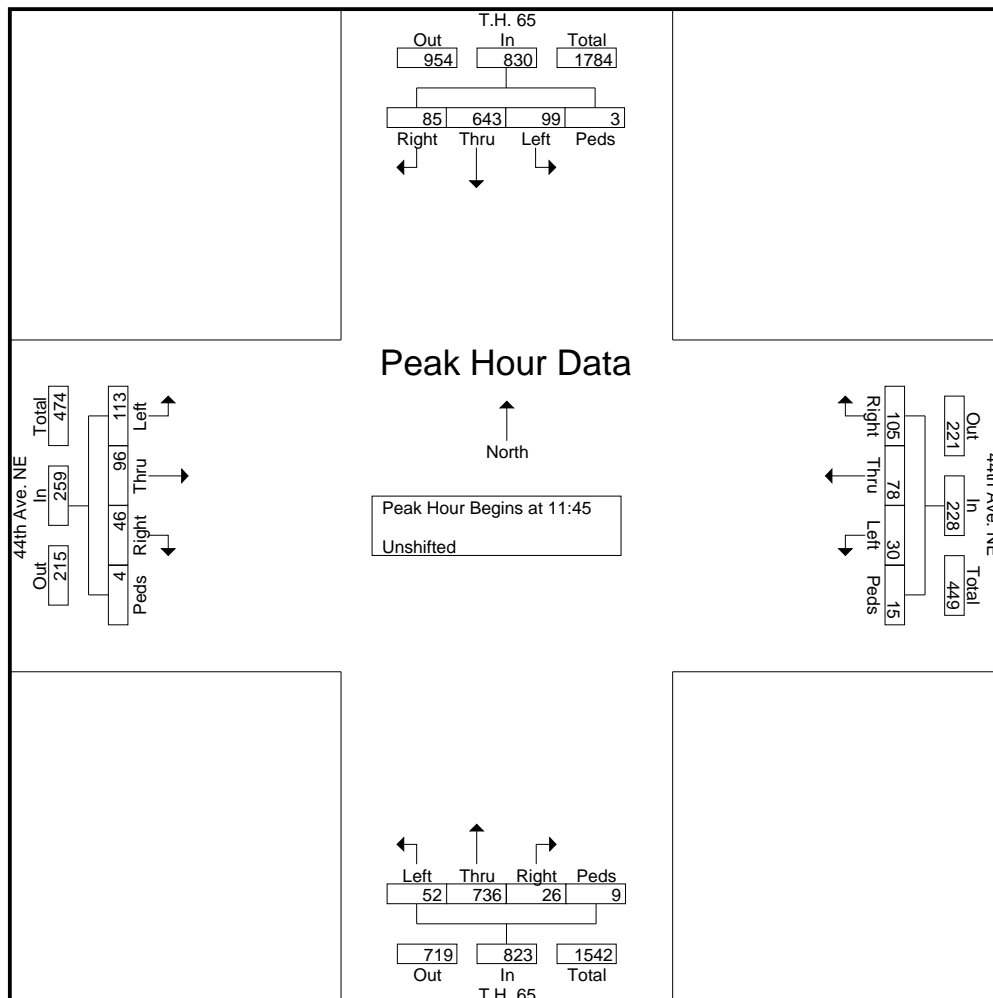



MINNESOTA DEPT OF TRANSPORTATION

TRAFFIC DATA COLLECTION - METRO

File Name : T.H. 65 at 44th
 Site Code : 00000003
 Start Date : 7/30/2003
 Page No : 5

Start Time	T.H. 65 Southbound					44th Ave. NE Westbound					T.H. 65 Northbound					44th Ave. NE Eastbound					Int. Total
	Left	Thru	Right	Peds	App. Total	Left	Thru	Right	Peds	App. Total	Left	Thru	Right	Peds	App. Total	Left	Thru	Right	Peds	App. Total	
Peak Hour Analysis From 14:00 to 17:45 - Peak 1 of 1																					
Peak Hour for Entire Intersection Begins at 16:30																					
16:30	16	205	25	1	247	11	21	35	0	67	20	275	9	2	306	17	36	14	2	69	689
16:45	22	156	26	0	204	11	24	37	16	88	16	281	11	0	308	30	36	12	1	79	679
17:00	16	186	22	2	226	9	30	35	1	75	15	249	14	2	280	25	25	14	0	64	645
17:15	11	189	32	0	232	7	25	28	4	64	14	285	7	1	307	27	25	14	1	67	670
Total Volume	65	736	105	3	909	38	100	135	21	294	65	1090	41	5	1201	99	122	54	4	279	2683
% App. Total	7.2	81	11.6	0.3		12.9	34	45.9	7.1		5.4	90.8	3.4	0.4		35.5	43.7	19.4	1.4		
PHF	.739	.898	.820	.375	.920	.864	.833	.912	.328	.835	.813	.956	.732	.625	.975	.825	.847	.964	.500	.883	.974

