



MINNESOTA DEPT OF TRANSPORTATION

TRAFFIC DATA COLLECTION - METRO

Location: TH 110 @ TH 149 (DODD RD) 2006

File Name : TH 110 @ TH 149 (DODD RD) 2006

REF. PT.: 002+00.039

Site Code : 00000000

Jamar# 1358/MAR

Start Date : 4/6/2006

TURN MOVEMENT COUNT

Page No : 1

Groups Printed- Cars & Trucks

Start Time	TH 149 (DODD RD) Southbound					TH 110 Westbound					TH 149 (DODD RD) Northbound					TH 110 Eastbound					Int. Total
	Left	Thru	Right	Peds	App. Total	Left	Thru	Right	Peds	App. Total	Left	Thru	Right	Peds	App. Total	Left	Thru	Right	Peds	App. Total	
06:00	1	2	19	0	22	7	154	1	0	162	12	8	7	0	27	6	44	10	0	60	271
06:15	4	14	34	0	52	10	159	1	0	170	14	4	12	0	30	12	65	11	0	88	340
06:30	4	16	37	0	57	21	207	2	0	230	24	11	10	0	45	8	92	13	0	113	445
06:45	3	28	31	0	62	21	200	2	0	223	32	18	10	0	60	34	110	19	0	163	508
Total	12	60	121	0	193	59	720	6	0	785	82	41	39	0	162	60	311	53	0	424	1564
07:00	11	31	44	1	87	18	233	1	0	252	52	20	11	0	83	34	111	31	0	176	598
07:15	16	54	82	0	152	22	247	6	0	275	52	44	21	0	117	57	142	62	0	261	805
07:30	11	70	80	1	162	27	295	8	1	331	66	43	26	0	135	31	113	74	0	218	846
07:45	4	69	57	1	131	26	244	3	0	273	43	32	25	0	100	31	164	84	0	279	783
Total	42	224	263	3	532	93	1019	18	1	1131	213	139	83	0	435	153	530	251	0	934	3032
08:00	12	34	54	0	100	31	211	4	0	246	64	42	18	0	124	31	117	40	1	189	659
08:15	5	35	51	0	91	17	210	8	3	238	44	25	20	4	93	18	152	26	0	196	618
08:30	12	43	49	0	104	22	163	6	0	191	23	26	11	0	60	18	98	37	0	153	508
08:45	13	44	40	3	100	22	172	4	4	202	46	28	20	4	98	22	116	29	3	170	570
Total	42	156	194	3	395	92	756	22	7	877	177	121	69	8	375	89	483	132	4	708	2355
15:00	8	23	32	0	63	14	169	7	0	190	45	32	37	4	118	35	222	59	0	316	687
15:15	6	25	34	1	66	15	175	11	0	201	35	35	24	0	94	35	252	58	1	346	707
15:30	12	37	42	1	92	26	181	15	0	222	39	36	31	5	111	37	237	65	0	339	764
15:45	5	28	35	5	73	23	168	8	5	204	42	45	26	3	116	45	230	45	2	322	715
Total	31	113	143	7	294	78	693	41	5	817	161	148	118	12	439	152	941	227	3	1323	2873
16:00	9	37	32	0	78	32	175	5	0	212	48	50	36	3	137	28	253	42	0	323	750
16:15	12	38	39	8	97	15	188	6	0	209	48	61	36	8	153	47	246	58	0	351	810
16:30	8	40	42	0	90	30	205	11	0	246	44	77	34	10	165	55	247	51	1	354	855
16:45	17	51	49	9	126	34	226	11	4	275	35	62	27	2	126	45	252	55	0	352	879
Total	46	166	162	17	391	111	794	33	4	942	175	250	133	23	581	175	998	206	1	1380	3294
17:00	8	42	28	0	78	25	203	7	3	238	68	75	45	7	195	36	291	45	2	374	885
17:15	7	38	54	0	99	16	179	7	2	204	54	56	33	2	145	46	246	56	0	348	796
17:30	12	40	34	5	91	21	147	11	3	182	49	72	25	2	148	44	223	50	1	318	739
17:45	9	29	34	0	72	24	162	4	1	191	47	52	30	0	129	48	225	48	0	321	713
Total	36	149	150	5	340	86	691	29	9	815	218	255	133	11	617	174	985	199	3	1361	3133
Grand Total	209	868	1033	35	2145	519	4673	149	26	5367	1026	954	575	54	2609	803	4248	1068	11	6130	16251
Apprch %	9.7	40.5	48.2	1.6		9.7	87.1	2.8	0.5		39.3	36.6	22	2.1		13.1	69.3	17.4	0.2		
Total %	1.3	5.3	6.4	0.2	13.2	3.2	28.8	0.9	0.2	33	6.3	5.9	3.5	0.3	16.1	4.9	26.1	6.6	0.1	37.7	



MINNESOTA DEPT OF TRANSPORTATION

TRAFFIC DATA COLLECTION - METRO

File Name : TH 110 @ TH 149 (DODD RD) 2006
 Site Code : 00000000
 Start Date : 4/6/2006
 Page No : 2

Start Time	TH 149 (DODD RD) Southbound					TH 110 Westbound					TH 149 (DODD RD) Northbound					TH 110 Eastbound					Int. Total
	Left	Thru	Right	Peds	App. Total	Left	Thru	Right	Peds	App. Total	Left	Thru	Right	Peds	App. Total	Left	Thru	Right	Peds	App. Total	
Peak Hour Analysis From 06:00 to 12:00 - Peak 1 of 1																					
Peak Hour for Entire Intersection Begins at 07:15																					
07:15	16	54	82	0	152	22	247	6	0	275	52	44	21	0	117	57	142	62	0	261	805
07:30	11	70	80	1	162	27	295	8	1	331	66	43	26	0	135	31	113	74	0	218	846
07:45	4	69	57	1	131	26	244	3	0	273	43	32	25	0	100	31	164	84	0	279	783
08:00	12	34	54	0	100	31	211	4	0	246	64	42	18	0	124	31	117	40	1	189	659
Total Volume	43	227	273	2	545	106	997	21	1	1125	225	161	90	0	476	150	536	260	1	947	3093
% App. Total	7.9	41.7	50.1	0.4		9.4	88.6	1.9	0.1		47.3	33.8	18.9	0		15.8	56.6	27.5	0.1		
PHF	.672	.811	.832	.500	.841	.855	.845	.656	.250	.850	.852	.915	.865	.000	.881	.658	.817	.774	.250	.849	.914

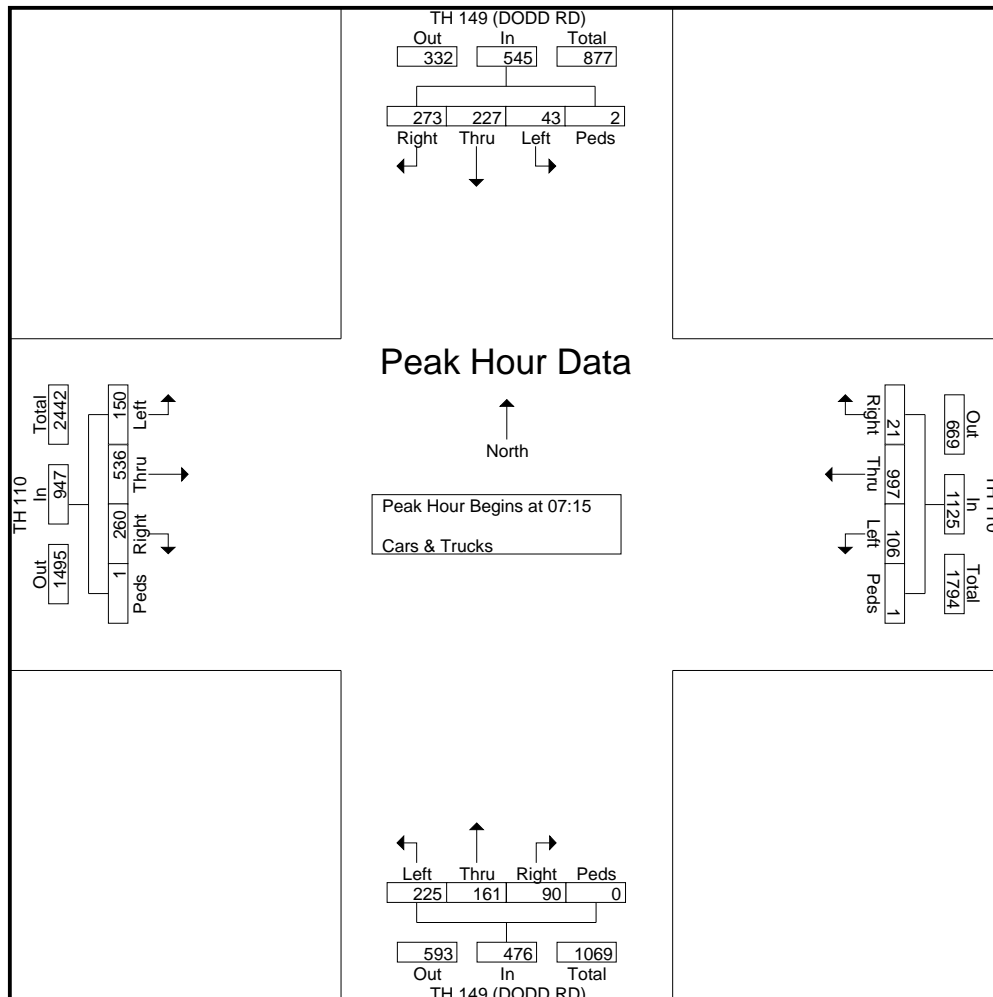



MINNESOTA DEPT OF TRANSPORTATION

TRAFFIC DATA COLLECTION - METRO

File Name : TH 110 @ TH 149 (DODD RD) 2006
 Site Code : 00000000
 Start Date : 4/6/2006
 Page No : 3

Start Time	TH 149 (DODD RD) Southbound					TH 110 Westbound					TH 149 (DODD RD) Northbound					TH 110 Eastbound					Int. Total
	Left	Thru	Right	Peds	App. Total	Left	Thru	Right	Peds	App. Total	Left	Thru	Right	Peds	App. Total	Left	Thru	Right	Peds	App. Total	
Peak Hour Analysis From 12:15 to 17:45 - Peak 1 of 1																					
Peak Hour for Entire Intersection Begins at 16:15																					
16:15	12	38	39	8	97	15	188	6	0	209	48	61	36	8	153	47	246	58	0	351	810
16:30	8	40	42	0	90	30	205	11	0	246	44	77	34	10	165	55	247	51	1	354	855
16:45	17	51	49	9	126	34	226	11	4	275	35	62	27	2	126	45	252	55	0	352	879
17:00	8	42	28	0	78	25	203	7	3	238	68	75	45	7	195	36	291	45	2	374	885
Total Volume	45	171	158	17	391	104	822	35	7	968	195	275	142	27	639	183	1036	209	3	1431	3429
% App. Total	11.5	43.7	40.4	4.3		10.7	84.9	3.6	0.7		30.5	43	22.2	4.2		12.8	72.4	14.6	0.2		
PHF	.662	.838	.806	.472	.776	.765	.909	.795	.438	.880	.717	.893	.789	.675	.819	.832	.890	.901	.375	.957	.969

