



# MINNESOTA DEPT OF TRANSPORTATION

## TRAFFIC DATA COLLECTION - METRO

TH-61 NB at 210th Ave N, Forest Lake

File Name : th-61 nb at 210th ave n 2011

Ref.Pt.: 159.209

Site Code : 00000000

JAMAR # 631 BR

Start Date : 6/1/2011

TURN MOVEMENT COUNT

Page No : 1

NOTE: I-35E reduced to 1 lane each direction south of Forest Lake

### Groups Printed- Cars & Trucks

Start Time	TH-61 NB / Forest Blvd Southbound				210th St N Westbound				TH-61 NB / Forest Blvd Northbound				210th St N Eastbound				Int. Total
	Left	Thru	Right	Peds	Left	Thru	Right	Peds	Left	Thru	Right	Peds	Left	Thru	Right	Peds	
06:00	0	0	0	0	0	36	1	0	14	13	1	0	0	6	0	0	71
06:15	0	0	0	0	0	30	3	0	8	14	0	0	0	4	0	0	59
06:30	0	0	0	0	0	33	9	0	4	17	1	0	0	10	0	0	74
06:45	0	0	0	0	0	25	10	0	8	26	5	0	0	23	0	0	97
Total	0	0	0	0	0	124	23	0	34	70	7	0	0	43	0	0	301
07:00	0	0	0	0	0	35	9	0	9	30	6	0	0	32	0	0	121
07:15	0	0	0	0	0	52	26	0	15	44	12	0	0	86	0	0	235
07:30	0	0	0	0	0	44	92	0	14	52	7	0	0	114	0	0	323
07:45	0	0	0	0	0	28	19	0	7	58	5	0	0	105	0	0	222
Total	0	0	0	0	0	159	146	0	45	184	30	0	0	337	0	0	901
08:00	0	0	0	0	0	20	6	0	10	43	3	0	0	20	0	0	102
08:15	0	0	0	0	0	21	7	0	10	64	1	0	0	13	0	0	116
08:30	0	0	0	0	0	12	12	0	10	57	1	0	1	12	0	0	105
08:45	0	0	0	0	0	18	24	0	14	63	2	0	0	9	0	0	130
Total	0	0	0	0	0	71	49	0	44	227	7	0	1	54	0	0	453
*** BREAK ***																	
14:00	0	0	0	0	0	12	9	0	16	107	3	0	1	32	0	0	180
14:15	0	0	0	0	0	23	52	0	10	70	5	0	2	34	0	0	196
14:30	0	0	0	0	0	57	71	0	8	95	3	0	0	36	0	0	270
14:45	0	0	0	0	0	28	32	0	12	85	5	0	2	36	0	0	200
Total	0	0	0	0	0	120	164	0	46	357	16	0	5	138	0	0	846
15:00	0	0	0	0	0	13	15	0	11	94	4	0	1	28	0	0	166
15:15	0	0	0	0	0	15	11	0	20	97	2	0	3	38	0	0	186
15:30	0	0	0	0	0	31	15	0	19	100	6	0	0	36	0	0	207
15:45	0	0	0	0	0	22	27	0	17	112	4	0	0	41	0	0	223
Total	0	0	0	0	0	81	68	0	67	403	16	0	4	143	0	0	782
16:00	0	0	0	0	0	23	16	0	17	110	2	0	1	38	0	0	207
16:15	0	0	0	0	0	31	17	0	16	142	5	0	0	53	0	0	264
16:30	0	0	0	0	0	24	28	0	27	132	5	0	0	58	0	0	274
16:45	0	0	0	0	0	16	24	0	15	130	5	0	1	59	0	0	250
Total	0	0	0	0	0	94	85	0	75	514	17	0	2	208	0	0	995
17:00	0	0	0	0	0	19	19	0	18	126	4	0	1	60	0	0	247
17:15	0	0	0	0	0	7	21	0	6	123	4	0	0	68	0	0	229
Grand Total	0	0	0	0	0	675	575	0	335	2004	101	0	13	1051	0	0	4754
Apprch %	0	0	0	0	0	54	46	0	13.7	82.1	4.1	0	1.2	98.8	0	0	
Total %	0	0	0	0	0	14.2	12.1	0	7	42.2	2.1	0	0.3	22.1	0	0	



# MINNESOTA DEPT OF TRANSPORTATION

## TRAFFIC DATA COLLECTION - METRO

TH-61 NB at 210th Ave N, Forest Lake

Ref.Pt.: 159.209

JAMAR # 631 BR

TURN MOVEMENT COUNT

File Name : th-61 nb at 210th ave n 2011

Site Code : 00000000

Start Date : 6/1/2011

Page No : 2

Start Time	TH-61 NB / Forest Blvd Southbound					210th St N Westbound					TH-61 NB / Forest Blvd Northbound					210th St N Eastbound					Int. Total
	Left	Thru	Right	Peds	App. Total	Left	Thru	Right	Peds	App. Total	Left	Thru	Right	Peds	App. Total	Left	Thru	Right	Peds	App. Total	
Peak Hour Analysis From 06:00 to 08:45 - Peak 1 of 1																					
Peak Hour for Entire Intersection Begins at 07:00																					
07:00	0	0	0	0	0	0	35	9	0	44	9	30	6	0	45	0	32	0	0	32	121
07:15	0	0	0	0	0	0	52	26	0	78	15	44	12	0	71	0	86	0	0	86	235
07:30	0	0	0	0	0	0	44	92	0	136	14	52	7	0	73	0	114	0	0	114	323
07:45	0	0	0	0	0	0	28	19	0	47	7	58	5	0	70	0	105	0	0	105	222
Total Volume	0	0	0	0	0	0	159	146	0	305	45	184	30	0	259	0	337	0	0	337	901
% App. Total	0	0	0	0	0	0	52.1	47.9	0		17.4	71	11.6	0		0	100	0	0		
PHF	.000	.000	.000	.000	.000	.000	.764	.397	.000	.561	.750	.793	.625	.000	.887	.000	.739	.000	.000	.739	.697

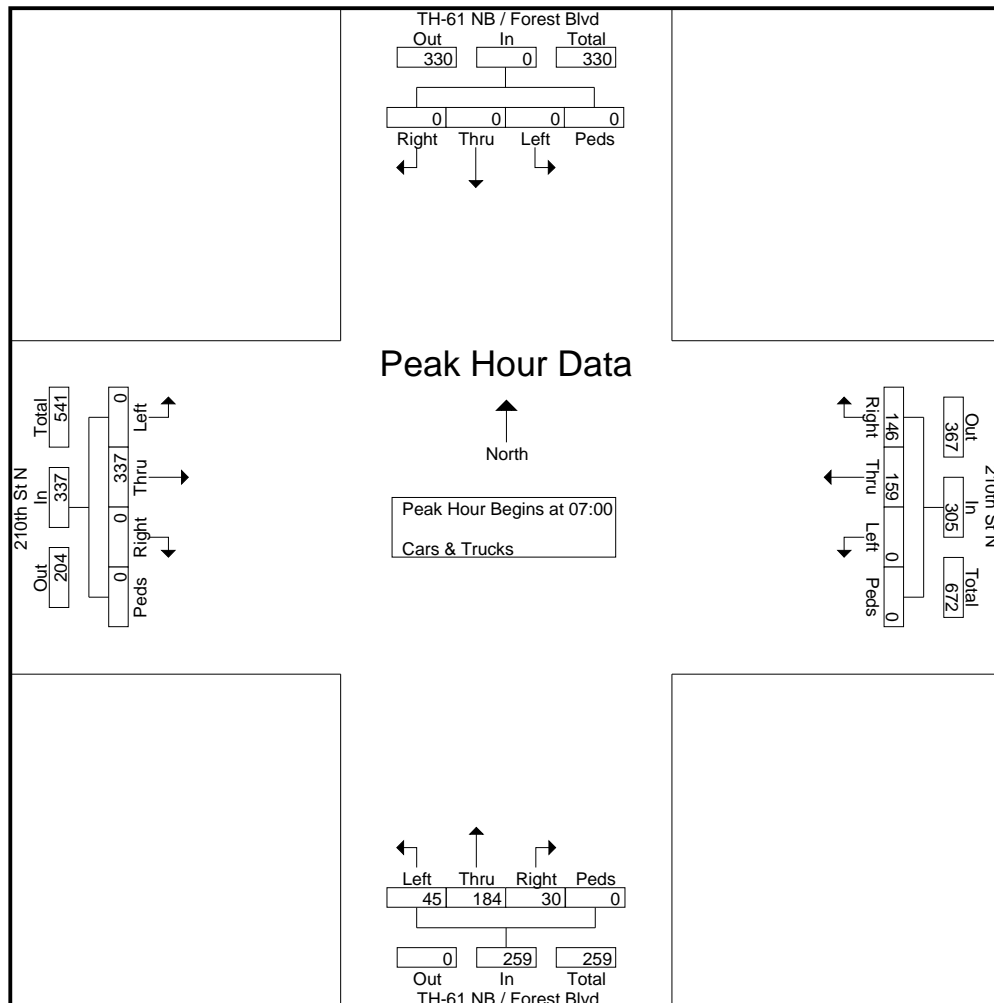



# MINNESOTA DEPT OF TRANSPORTATION

## TRAFFIC DATA COLLECTION - METRO

TH-61 NB at 210th Ave N, Forest Lake  
 Ref.Pt.: 159.209  
 JAMAR # 631 BR  
 TURN MOVEMENT COUNT

File Name : th-61 nb at 210th ave n 2011  
 Site Code : 00000000  
 Start Date : 6/1/2011  
 Page No : 3

Start Time	TH-61 NB / Forest Blvd Southbound					210th St N Westbound					TH-61 NB / Forest Blvd Northbound					210th St N Eastbound					Int. Total
	Left	Thru	Right	Peds	App. Total	Left	Thru	Right	Peds	App. Total	Left	Thru	Right	Peds	App. Total	Left	Thru	Right	Peds	App. Total	
Peak Hour Analysis From 14:00 to 17:15 - Peak 1 of 1 Peak Hour for Entire Intersection Begins at 16:15																					
16:15	0	0	0	0	0	0	31	17	0	48	16	142	5	0	163	0	53	0	0	53	264
16:30	0	0	0	0	0	0	24	28	0	52	27	132	5	0	164	0	58	0	0	58	274
16:45	0	0	0	0	0	0	16	24	0	40	15	130	5	0	150	1	59	0	0	60	250
17:00	0	0	0	0	0	0	19	19	0	38	18	126	4	0	148	1	60	0	0	61	247
Total Volume	0	0	0	0	0	0	90	88	0	178	76	530	19	0	625	2	230	0	0	232	1035
% App. Total	0	0	0	0	0	0	50.6	49.4	0		12.2	84.8	3	0		0.9	99.1	0	0		
PHF	.000	.000	.000	.000	.000	.000	.726	.786	.000	.856	.704	.933	.950	.000	.953	.500	.958	.000	.000	.951	.944

