



# Minnesota Dept. of Transportation

## Traffic Data Collection -Metro

TH-61 AT 165TH ST N HUGO  
 REF PT; 154.633  
 Jamar # T-2638 CAH  
 TURN MOVEMENT COUNT

File Name : TH-61 AT 165TH ST N 2012  
 Site Code : 154.633  
 Start Date : 1/10/2012  
 Page No : 1

### Groups Printed- Unshifted

Start Time	TH-61 Southbound				165TH ST N Westbound				TH-61 Northbound				165TH ST N Eastbound				Int. Total
	Right	Thru	Left	Peds	Right	Thru	Left	Peds	Right	Thru	Left	Peds	Right	Thru	Left	Peds	
06:00	1	51	0	0	0	0	4	0	0	10	0	0	1	0	0	0	67
06:15	2	68	0	0	2	0	2	0	0	20	1	0	3	0	0	0	98
06:30	1	103	0	0	0	0	2	0	0	21	0	0	0	0	1	0	128
06:45	0	114	0	0	1	0	4	0	1	30	0	0	3	0	0	0	153
Total	4	336	0	0	3	0	12	0	1	81	1	0	7	0	1	0	446
07:00	1	103	0	0	0	0	4	0	2	24	2	0	0	0	0	0	136
07:15	0	103	2	0	1	1	4	0	0	41	2	0	2	0	0	0	156
07:30	1	117	1	0	1	0	3	0	0	44	1	0	2	0	1	0	171
07:45	2	103	3	0	1	1	0	0	1	38	1	0	2	0	1	0	153
Total	4	426	6	0	3	2	11	0	3	147	6	0	6	0	2	0	616
08:00	0	75	0	0	1	0	4	0	1	36	1	0	3	0	0	0	121
08:15	1	73	0	0	1	0	3	0	3	30	0	0	0	0	2	0	113
08:30	2	55	2	0	0	0	2	0	0	36	3	0	1	0	0	0	101
08:45	0	82	2	0	2	0	3	0	2	34	0	0	0	1	2	0	128
Total	3	285	4	0	4	0	12	0	6	136	4	0	4	1	4	0	463
*** BREAK ***																	
15:00	0	59	1	2	3	0	2	0	1	80	3	0	0	1	2	0	154
15:15	0	67	1	0	2	0	2	0	3	86	0	1	0	0	1	0	163
15:30	4	64	0	0	0	1	2	0	8	132	1	0	3	0	2	0	217
15:45	0	67	2	0	2	0	1	0	1	135	0	0	1	0	2	0	211
Total	4	257	4	2	7	1	7	0	13	433	4	1	4	1	7	0	745
16:00	1	59	2	0	0	1	3	0	0	124	0	0	1	0	3	0	194
16:15	2	67	1	0	4	1	0	0	2	124	1	0	2	0	1	0	205
16:30	0	74	4	0	0	0	2	0	3	135	2	0	0	0	1	0	221
16:45	0	58	2	0	0	0	0	0	6	139	0	0	2	0	1	0	208
Total	3	258	9	0	4	2	5	0	11	522	3	0	5	0	6	0	828
17:00	0	70	0	0	2	0	3	0	3	155	1	0	2	1	0	0	237
17:15	2	65	1	0	5	0	1	0	3	116	1	0	0	1	1	0	196
17:30	0	48	3	0	2	0	1	0	3	103	1	0	0	0	0	0	161
17:45	0	41	2	0	3	0	2	0	4	100	1	0	0	0	0	0	153
Total	2	224	6	0	12	0	7	0	13	474	4	0	2	2	1	0	747
Grand Total	20	1786	29	2	33	5	54	0	47	1793	22	1	28	4	21	0	3845
Apprch %	1.1	97.2	1.6	0.1	35.9	5.4	58.7	0	2.5	96.2	1.2	0.1	52.8	7.5	39.6	0	
Total %	0.5	46.4	0.8	0.1	0.9	0.1	1.4	0	1.2	46.6	0.6	0	0.7	0.1	0.5	0	



# Minnesota Dept. of Transportation

## Traffic Data Collection -Metro

TH-61 AT 165TH ST N HUGO  
 REF PT; 154.633  
 Jamar # T-2638 CAH  
 TURN MOVEMENT COUNT

File Name : TH-61 AT 165TH ST N 2012  
 Site Code : 154.633  
 Start Date : 1/10/2012  
 Page No : 2

Start Time	TH-61 Southbound					165TH ST N Westbound					TH-61 Northbound					165TH ST N Eastbound					Int. Total
	Right	Thru	Left	Peds	App. Total	Right	Thru	Left	Peds	App. Total	Right	Thru	Left	Peds	App. Total	Right	Thru	Left	Peds	App. Total	
Peak Hour Analysis From 06:00 to 08:45 - Peak 1 of 1																					
Peak Hour for Entire Intersection Begins at 06:45																					
06:45	0	114	0	0	114	1	0	4	0	5	1	30	0	0	31	3	0	0	0	3	153
07:00	1	103	0	0	104	0	0	4	0	4	2	24	2	0	28	0	0	0	0	0	136
07:15	0	103	2	0	105	1	1	4	0	6	0	41	2	0	43	2	0	0	0	2	156
07:30	1	117	1	0	119	1	0	3	0	4	0	44	1	0	45	2	0	1	0	3	171
Total Volume	2	437	3	0	442	3	1	15	0	19	3	139	5	0	147	7	0	1	0	8	616
% App. Total	0.5	98.9	0.7	0		15.8	5.3	78.9	0		2	94.6	3.4	0		87.5	0	12.5	0		
PHF	.500	.934	.375	.000	.929	.750	.250	.938	.000	.792	.375	.790	.625	.000	.817	.583	.000	.250	.000	.667	.901

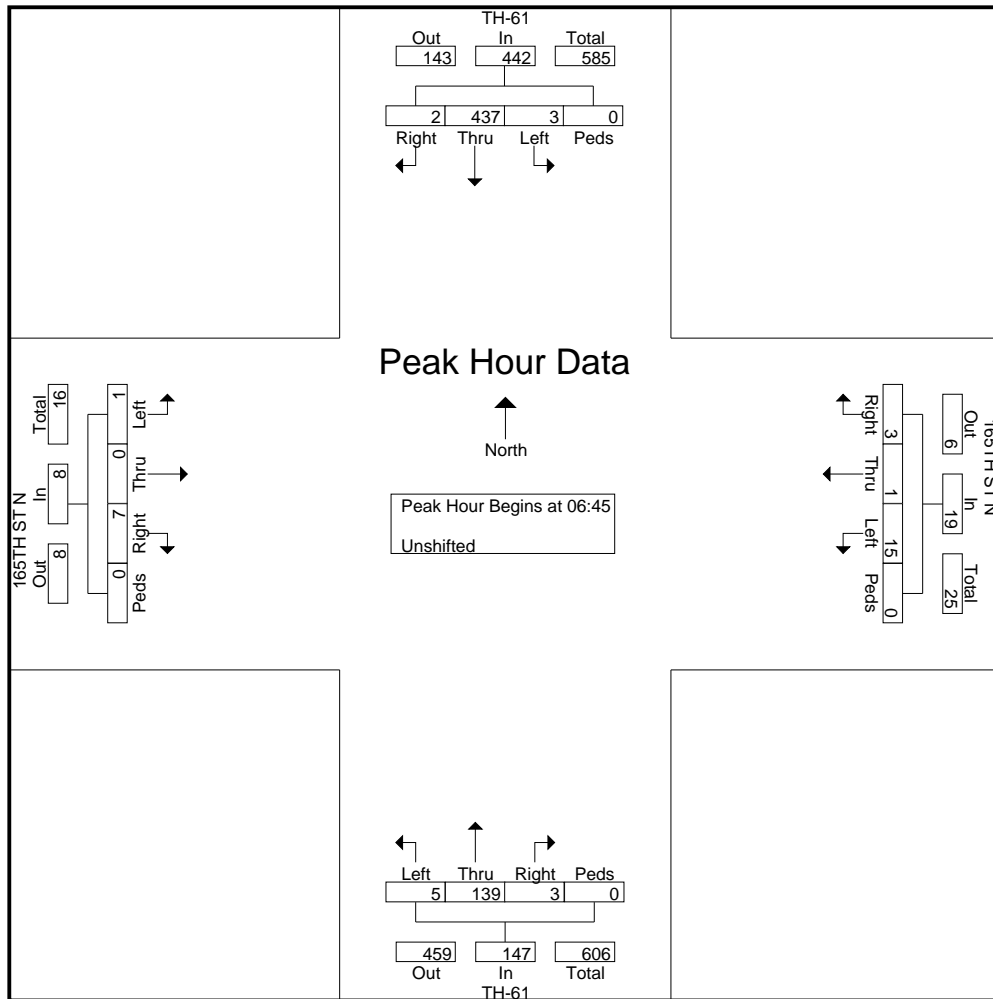



# Minnesota Dept. of Transportation

## Traffic Data Collection -Metro

TH-61 AT 165TH ST N HUGO  
 REF PT; 154.633  
 Jamar # T-2638 CAH  
 TURN MOVEMENT COUNT

File Name : TH-61 AT 165TH ST N 2012  
 Site Code : 154.633  
 Start Date : 1/10/2012  
 Page No : 3

Start Time	TH-61 Southbound					165TH ST N Westbound					TH-61 Northbound					165TH ST N Eastbound					Int. Total
	Rig ht	Thr u	Left	Ped s	App. Total	Rig ht	Thr u	Left	Ped s	App. Total	Right	Thr u	Left	Peds	App. Total	Right	Thr u	Left	Peds	App. Total	
Peak Hour Analysis From 15:00 to 17:45 - Peak 1 of 1																					
Peak Hour for Entire Intersection Begins at 16:15																					
16:15	2	67	1	0	70	4	1	0	0	5	2	124	1	0	127	2	0	1	0	3	205
16:30	0	74	4	0	78	0	0	2	0	2	3	135	2	0	140	0	0	1	0	1	221
16:45	0	58	2	0	60	0	0	0	0	0	6	139	0	0	145	2	0	1	0	3	208
17:00	0	70	0	0	70	2	0	3	0	5	3	155	1	0	159	2	1	0	0	3	237
Total Volume	2	269	7	0	278	6	1	5	0	12	14	553	4	0	571	6	1	3	0	10	871
% App. Total	0.7	96.8	2.5	0		50	8.3	41.7	0		2.5	96.8	0.7	0		60	10	30	0		
PHF	.250	.909	.438	.000	.891	.375	.250	.417	.000	.600	.583	.892	.500	.000	.898	.750	.250	.750	.000	.833	.919

