



MINNESOTA DEPT OF TRANSPORTATION

TRAFFIC DATA COLLECTION - METRO

TH-61 at Buffalo St (WBL)
 Ref.Pt.: 148.663
 Data by: Alliant Inc.
 TURN MOVEMENT COUNT

File Name : TH-61 at Buffalo St 2008
 Site Code : 00000119
 Start Date : 9/23/2008
 Page No : 1

Groups Printed- Unshifted

Start Time	TH-61 Southbound				Buffalo St Westbound				TH-61 Northbound				Buffalo St Eastbound				Int. Total
	Left	Thru	Right	Peds	Left	Thru	Right	Peds	Left	Thru	Right	Peds	Left	Thru	Right	Peds	
06:00	1	119	3	0	10	4	4	0	0	26	0	0	1	4	10	0	182
06:15	6	154	5	0	16	3	3	0	6	39	2	0	4	5	10	0	253
06:30	9	211	13	0	19	7	2	0	2	46	1	0	8	6	9	0	333
06:45	8	228	14	0	25	21	13	0	1	65	2	0	6	5	17	0	405
Total	24	712	35	0	70	35	22	0	9	176	5	0	19	20	46	0	1173
07:00	10	283	33	0	28	20	22	0	3	49	3	0	11	6	18	0	486
07:15	16	287	16	0	38	24	19	0	6	60	2	0	17	8	25	0	518
07:30	6	273	15	0	25	17	10	0	2	51	3	2	7	15	17	0	443
07:45	6	273	8	0	33	14	8	0	2	71	1	0	6	6	16	0	444
Total	38	1116	72	0	124	75	59	0	13	231	9	2	41	35	76	0	1891
08:00	6	180	5	1	14	5	12	0	1	52	3	0	10	3	17	0	309
08:15	4	166	2	0	18	9	14	0	2	57	5	0	6	2	7	0	292
08:30	13	158	7	0	20	8	6	0	2	65	4	0	9	2	5	0	299
08:45	25	129	8	0	21	11	6	0	4	46	14	0	10	8	5	0	287
Total	48	633	22	1	73	33	38	0	9	220	26	0	35	15	34	0	1187
09:00	18	136	3	0	30	9	11	0	4	58	25	0	3	3	10	0	310
09:15	13	102	4	0	20	5	8	0	4	53	26	0	9	12	8	0	264
*** BREAK ***																	
Total	31	238	7	0	50	14	19	0	8	111	51	0	12	15	18	0	574
*** BREAK ***																	
10:30	4	90	3	0	7	3	0	0	6	39	3	0	3	4	3	0	165
10:45	4	120	0	0	10	0	4	0	3	58	4	0	5	0	4	0	212
Total	8	210	3	0	17	3	4	0	9	97	7	0	8	4	7	0	377
11:00	3	90	2	0	6	2	4	0	6	61	9	0	1	1	2	0	187
11:15	12	90	2	0	13	2	3	0	3	81	13	0	4	3	3	0	229
11:30	10	71	2	0	31	4	17	0	5	70	15	0	7	2	4	0	238
11:45	3	82	6	0	35	10	5	0	11	113	7	0	4	5	9	0	290
Total	28	333	12	0	85	18	29	0	25	325	44	0	16	11	18	0	944
12:00	5	102	1	0	15	8	7	0	7	98	8	0	8	8	4	0	271
12:15	11	98	5	0	16	2	5	0	8	82	4	0	0	4	5	0	240
12:30	4	80	3	1	12	4	8	0	9	87	10	0	4	8	2	0	232
12:45	4	111	6	0	2	4	4	0	5	73	12	0	1	4	3	0	229
Total	24	391	15	1	45	18	24	0	29	340	34	0	13	24	14	0	972
13:00	2	105	10	1	7	5	6	0	5	85	7	0	8	6	9	0	256
13:15	7	91	3	0	8	3	5	0	8	73	6	0	6	4	5	0	219
*** BREAK ***																	
Total	9	196	13	1	15	8	11	0	13	158	13	0	14	10	14	0	475
*** BREAK ***																	
14:30	6	76	5	0	6	1	3	0	9	85	13	0	6	10	4	0	224
14:45	8	95	3	0	8	7	4	0	18	171	25	0	12	4	4	0	359
Total	14	171	8	0	14	8	7	0	27	256	38	0	18	14	8	0	583
15:00	11	95	9	0	8	10	19	0	11	149	18	0	7	7	4	0	348
15:15	6	100	6	0	7	4	16	0	7	180	8	0	13	9	5	0	361
15:30	7	113	9	0	5	14	16	0	10	204	16	0	16	16	7	0	433
15:45	18	122	2	1	4	8	10	0	6	188	9	0	19	12	7	0	406
Total	42	430	26	1	24	36	61	0	34	721	51	0	55	44	23	0	1548



MINNESOTA DEPT OF TRANSPORTATION

TRAFFIC DATA COLLECTION - METRO

TH-61 at Buffalo St (WBL)

Ref.Pt.: 148.663

Data by: Alliant Inc.

TURN MOVEMENT COUNT

File Name : TH-61 at Buffalo St 2008

Site Code : 00000119

Start Date : 9/23/2008

Page No : 2

Groups Printed- Unshifted

Start Time	TH-61 Southbound				Buffalo St Westbound				TH-61 Northbound				Buffalo St Eastbound				Int. Total
	Left	Thru	Right	Peds	Left	Thru	Right	Peds	Left	Thru	Right	Peds	Left	Thru	Right	Peds	
16:00	13	120	6	0	11	4	9	0	10	164	23	0	11	14	6	0	391
16:15	3	116	3	0	3	4	8	0	9	186	12	0	11	11	4	1	371
16:30	7	130	1	0	2	24	9	0	8	184	17	0	14	24	4	0	424
16:45	10	170	17	0	5	11	10	0	16	202	19	0	20	21	8	0	509
Total	33	536	27	0	21	43	36	0	43	736	71	0	56	70	22	1	1695
17:00	9	127	14	0	12	19	14	0	13	204	15	0	14	27	5	0	473
17:15	9	99	4	0	10	7	10	0	22	218	12	0	16	17	8	0	432
17:30	6	88	3	0	7	3	11	0	3	242	18	0	17	20	9	0	427
17:45	16	100	6	0	10	10	7	0	16	205	17	0	15	17	5	0	424
Total	40	414	27	0	39	39	42	0	54	869	62	0	62	81	27	0	1756
Grand Total	339	5380	267	4	577	330	352	0	273	4240	411	2	349	343	307	1	13175
Apprch %	5.7	89.8	4.5	0.1	45.8	26.2	28	0	5.5	86.1	8.3	0	34.9	34.3	30.7	0.1	
Total %	2.6	40.8	2	0	4.4	2.5	2.7	0	2.1	32.2	3.1	0	2.6	2.6	2.3	0	



MINNESOTA DEPT OF TRANSPORTATION

TRAFFIC DATA COLLECTION - METRO

TH-61 at Buffalo St (WBL)
 Ref.Pt.: 148.663
 Data by: Alliant Inc.
 TURN MOVEMENT COUNT

File Name : TH-61 at Buffalo St 2008
 Site Code : 00000119
 Start Date : 9/23/2008
 Page No : 3

Start Time	TH-61 Southbound					Buffalo St Westbound					TH-61 Northbound					Buffalo St Eastbound					Int. Total
	Left	Thru	Right	Peds	App. Total	Left	Thru	Right	Peds	App. Total	Left	Thru	Right	Peds	App. Total	Left	Thru	Right	Peds	App. Total	
Peak Hour Analysis From 06:00 to 09:15 - Peak 1 of 1																					
Peak Hour for Entire Intersection Begins at 07:00																					
07:00	10	283	33	0	326	28	20	22	0	70	3	49	3	0	55	11	6	18	0	35	486
07:15	16	287	16	0	319	38	24	19	0	81	6	60	2	0	68	17	8	25	0	50	518
07:30	6	273	15	0	294	25	17	10	0	52	2	51	3	2	58	7	15	17	0	39	443
07:45	6	273	8	0	287	33	14	8	0	55	2	71	1	0	74	6	6	16	0	28	444
Total Volume	38	1116	72	0	1226	124	75	59	0	258	13	231	9	2	255	41	35	76	0	152	1891
% App. Total	3.1	91	5.9	0		48.1	29.1	22.9	0		5.1	90.6	3.5	0.8		27	23	50	0		
PHF	.594	.972	.545	.000	.940	.816	.781	.670	.000	.796	.542	.813	.750	.250	.861	.603	.583	.760	.000	.760	.913

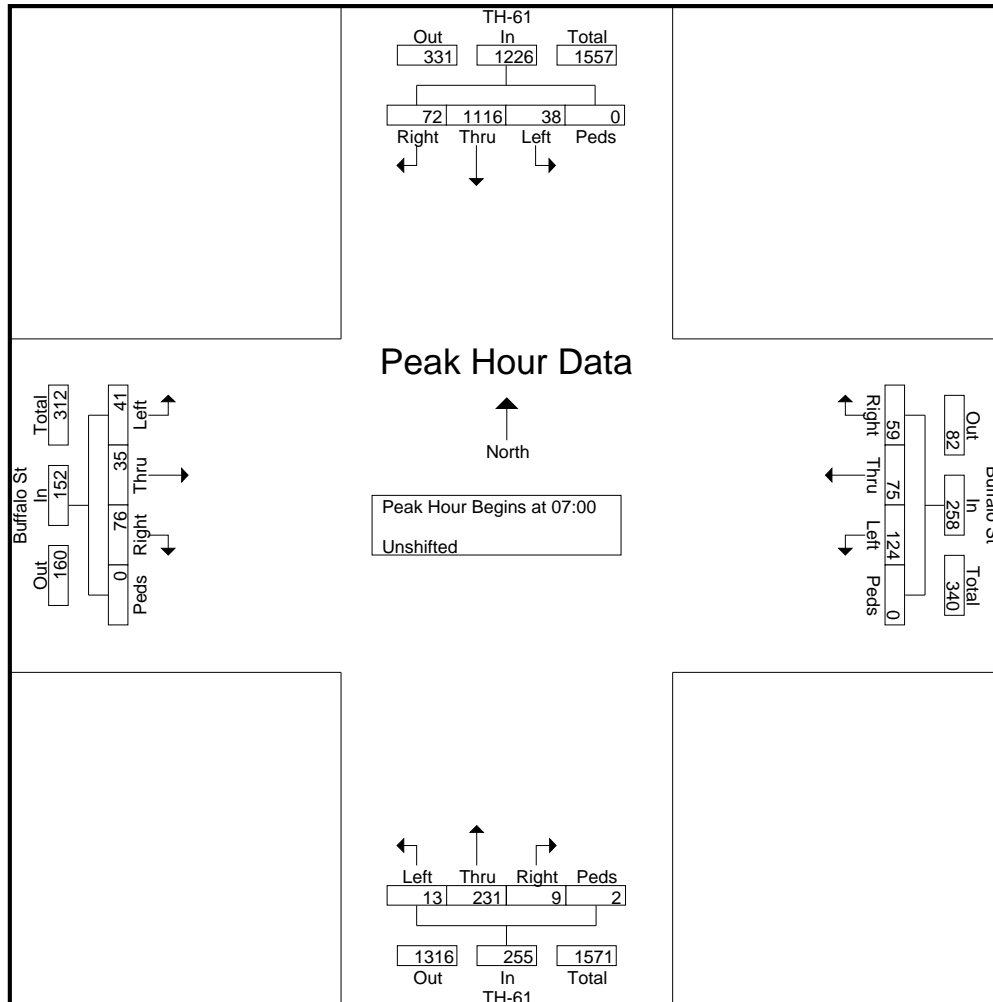



MINNESOTA DEPT OF TRANSPORTATION

TRAFFIC DATA COLLECTION - METRO

TH-61 at Buffalo St (WBL)
 Ref.Pt.: 148.663
 Data by: Alliant Inc.
 TURN MOVEMENT COUNT

File Name : TH-61 at Buffalo St 2008
 Site Code : 00000119
 Start Date : 9/23/2008
 Page No : 4

Start Time	TH-61 Southbound					Buffalo St Westbound					TH-61 Northbound					Buffalo St Eastbound					Int. Total
	Left	Thru	Right	Peds	App. Total	Left	Thru	Right	Peds	App. Total	Left	Thru	Right	Peds	App. Total	Left	Thru	Right	Peds	App. Total	
Peak Hour Analysis From 14:30 to 17:45 - Peak 1 of 1																					
Peak Hour for Entire Intersection Begins at 16:45																					
16:45	10	170	17	0	197	5	11	10	0	26	16	202	19	0	237	20	21	8	0	49	509
17:00	9	127	14	0	150	12	19	14	0	45	13	204	15	0	232	14	27	5	0	46	473
17:15	9	99	4	0	112	10	7	10	0	27	22	218	12	0	252	16	17	8	0	41	432
17:30	6	88	3	0	97	7	3	11	0	21	3	242	18	0	263	17	20	9	0	46	427
Total Volume	34	484	38	0	556	34	40	45	0	119	54	866	64	0	984	67	85	30	0	182	1841
% App. Total	6.1	87.1	6.8	0		28.6	33.6	37.8	0		5.5	88	6.5	0		36.8	46.7	16.5	0		
PHF	.850	.712	.559	.000	.706	.708	.526	.804	.000	.661	.614	.895	.842	.000	.935	.838	.787	.833	.000	.929	.904

