



MINNESOTA DEPT OF TRANSPORTATION

TRAFFIC DATA COLLECTION - METRO

TH-61 at 7th St. (White Bear Lake)

Ref.Pt.: 147.471

Data by: Alliant Inc.

TURN MOVEMENT COUNT

File Name : TH-61 at 7th St WBL 2008

Site Code : 00000117

Start Date : 9/10/2008

Page No : 1

Groups Printed- Unshifted

Start Time	TH-61 Southbound				7th St. Westbound				TH-61 Northbound				7th St. Eastbound				Int. Total
	Left	Thru	Right	Peds	Left	Thru	Right	Peds	Left	Thru	Right	Peds	Left	Thru	Right	Peds	
06:00	1	168	0	0	0	0	0	0	1	57	0	0	0	1	6	0	234
06:15	2	214	0	0	2	0	1	0	1	65	0	0	3	1	4	1	294
06:30	3	274	1	0	2	0	2	0	2	61	0	0	0	1	6	0	352
06:45	4	359	2	1	2	0	1	1	3	96	4	0	0	1	11	0	485
Total	10	1015	3	1	6	0	4	1	7	279	4	0	3	4	27	1	1365
07:00	11	381	3	3	2	0	1	1	12	114	6	2	5	3	24	0	568
07:15	10	434	3	0	4	2	0	0	28	140	4	0	6	3	33	0	667
07:30	5	391	8	0	7	0	2	0	12	110	2	0	3	0	19	0	559
07:45	6	399	6	0	2	5	4	0	13	122	4	2	14	3	34	0	614
Total	32	1605	20	3	15	7	7	1	65	486	16	4	28	9	110	0	2408
08:00	3	300	6	0	7	1	6	0	3	125	4	0	2	2	15	0	474
08:15	6	248	3	0	4	1	0	0	5	114	8	0	5	0	9	0	403
08:30	12	238	7	0	2	2	2	0	7	130	7	0	6	3	8	0	424
08:45	5	243	4	0	4	0	0	0	7	162	5	1	2	3	13	0	449
Total	26	1029	20	0	17	4	8	0	22	531	24	1	15	8	45	0	1750
09:00	12	204	6	0	1	0	1	0	7	118	7	1	3	2	11	0	373
09:15	9	198	3	0	2	1	0	0	9	132	4	0	3	2	7	0	370
*** BREAK ***																	
Total	21	402	9	0	3	1	1	0	16	250	11	1	6	4	18	0	743
*** BREAK ***																	
10:30	19	131	3	0	6	0	4	0	12	137	5	0	3	0	6	0	326
10:45	8	145	1	0	7	1	2	0	10	157	6	1	3	2	7	0	350
Total	27	276	4	0	13	1	6	0	22	294	11	1	6	2	13	0	676
11:00	5	155	3	0	7	2	2	0	7	162	7	0	7	1	8	0	366
11:15	3	198	3	1	9	1	1	0	8	189	7	0	5	3	7	1	436
11:30	9	142	6	0	14	1	0	0	10	167	9	0	2	3	6	0	369
11:45	7	135	6	0	7	2	4	0	12	168	11	0	7	2	8	0	369
Total	24	630	18	1	37	6	7	0	37	686	34	0	21	9	29	1	1540
12:00	11	118	4	0	4	0	3	0	12	179	7	0	17	2	10	0	367
12:15	6	168	5	1	3	0	1	0	17	188	12	0	4	5	12	0	422
12:30	7	165	5	0	1	0	1	0	13	189	8	0	10	2	17	0	418
12:45	8	156	9	0	5	0	3	0	9	176	7	0	10	3	17	0	403
Total	32	607	23	1	13	0	8	0	51	732	34	0	41	12	56	0	1610
*** BREAK ***																	
14:30	1	130	2	6	1	0	5	0	14	241	15	0	3	0	9	0	427
14:45	7	177	7	0	6	0	2	0	18	288	7	0	12	2	25	1	552
Total	8	307	9	6	7	0	7	0	32	529	22	0	15	2	34	1	979
15:00	7	162	4	0	9	1	4	0	19	221	11	0	17	1	19	0	475
15:15	5	131	4	0	3	1	8	0	8	281	6	0	10	2	7	1	467
15:30	8	148	7	0	4	3	5	0	19	296	4	0	12	6	14	0	526
15:45	15	193	23	0	3	1	2	0	20	331	9	0	17	9	23	0	646
Total	35	634	38	0	19	6	19	0	66	1129	30	0	56	18	63	1	2114
16:00	7	169	3	0	5	0	0	0	26	303	10	0	8	3	8	1	543
16:15	9	175	9	0	4	2	1	0	17	336	12	0	19	6	25	0	615
16:30	11	173	5	1	5	2	5	0	10	332	25	0	14	2	15	0	600
16:45	6	181	3	0	4	1	4	0	24	360	11	0	18	3	15	0	630
Total	33	698	20	1	18	5	10	0	77	1331	58	0	59	14	63	1	2388



MINNESOTA DEPT OF TRANSPORTATION

TRAFFIC DATA COLLECTION - METRO

TH-61 at 7th St. (White Bear Lake)

Ref.Pt.: 147.471

Data by: Alliant Inc.

TURN MOVEMENT COUNT

File Name : TH-61 at 7th St WBL 2008

Site Code : 00000117

Start Date : 9/10/2008

Page No : 2

Groups Printed- Unshifted

Start Time	TH-61 Southbound				7th St. Westbound				TH-61 Northbound				7th St. Eastbound				Int. Total
	Left	Thru	Right	Peds	Left	Thru	Right	Peds	Left	Thru	Right	Peds	Left	Thru	Right	Peds	
17:00	7	135	1	0	7	17	0	0	12	338	9	0	19	6	14	0	565
17:15	5	175	0	0	10	0	6	0	27	354	13	0	14	2	14	0	620
17:30	8	148	3	3	9	0	3	0	15	346	7	0	8	3	21	0	574
17:45	9	171	4	1	6	1	3	0	13	346	6	0	14	6	18	0	598
Total	29	629	8	4	32	18	12	0	67	1384	35	0	55	17	67	0	2357
18:00	7	142	5	1	4	0	3	0	13	319	5	0	6	2	16	1	524
Grand Total	284	7974	177	18	184	48	92	2	475	7950	284	7	311	101	541	6	18454
Apprch %	3.4	94.3	2.1	0.2	56.4	14.7	28.2	0.6	5.4	91.2	3.3	0.1	32.4	10.5	56.4	0.6	
Total %	1.5	43.2	1	0.1	1	0.3	0.5	0	2.6	43.1	1.5	0	1.7	0.5	2.9	0	



MINNESOTA DEPT OF TRANSPORTATION

TRAFFIC DATA COLLECTION - METRO

TH-61 at 7th St. (White Bear Lake)

Ref.Pt.: 147.471

Data by: Alliant Inc.

TURN MOVEMENT COUNT

File Name : TH-61 at 7th St WBL 2008

Site Code : 00000117

Start Date : 9/10/2008

Page No : 3

Start Time	TH-61 Southbound					7th St. Westbound					TH-61 Northbound					7th St. Eastbound					Int. Total
	Left	Thru	Right	Peds	App. Total	Left	Thru	Right	Peds	App. Total	Left	Thru	Right	Peds	App. Total	Left	Thru	Right	Peds	App. Total	
Peak Hour Analysis From 06:00 to 09:15 - Peak 1 of 1																					
Peak Hour for Entire Intersection Begins at 07:00																					
07:00	11	381	3	3	398	2	0	1	1	4	12	114	6	2	134	5	3	24	0	32	568
07:15	10	434	3	0	447	4	2	0	0	6	28	140	4	0	172	6	3	33	0	42	667
07:30	5	391	8	0	404	7	0	2	0	9	12	110	2	0	124	3	0	19	0	22	559
07:45	6	399	6	0	411	2	5	4	0	11	13	122	4	2	141	14	3	34	0	51	614
Total Volume	32	1605	20	3	1660	15	7	7	1	30	65	486	16	4	571	28	9	110	0	147	2408
% App. Total	1.9	96.7	1.2	0.2		50	23.3	23.3	3.3		11.4	85.1	2.8	0.7		19	6.1	74.8	0		
PHF	.727	.925	.625	.250	.928	.536	.350	.438	.250	.682	.580	.868	.667	.500	.830	.500	.750	.809	.000	.721	.903

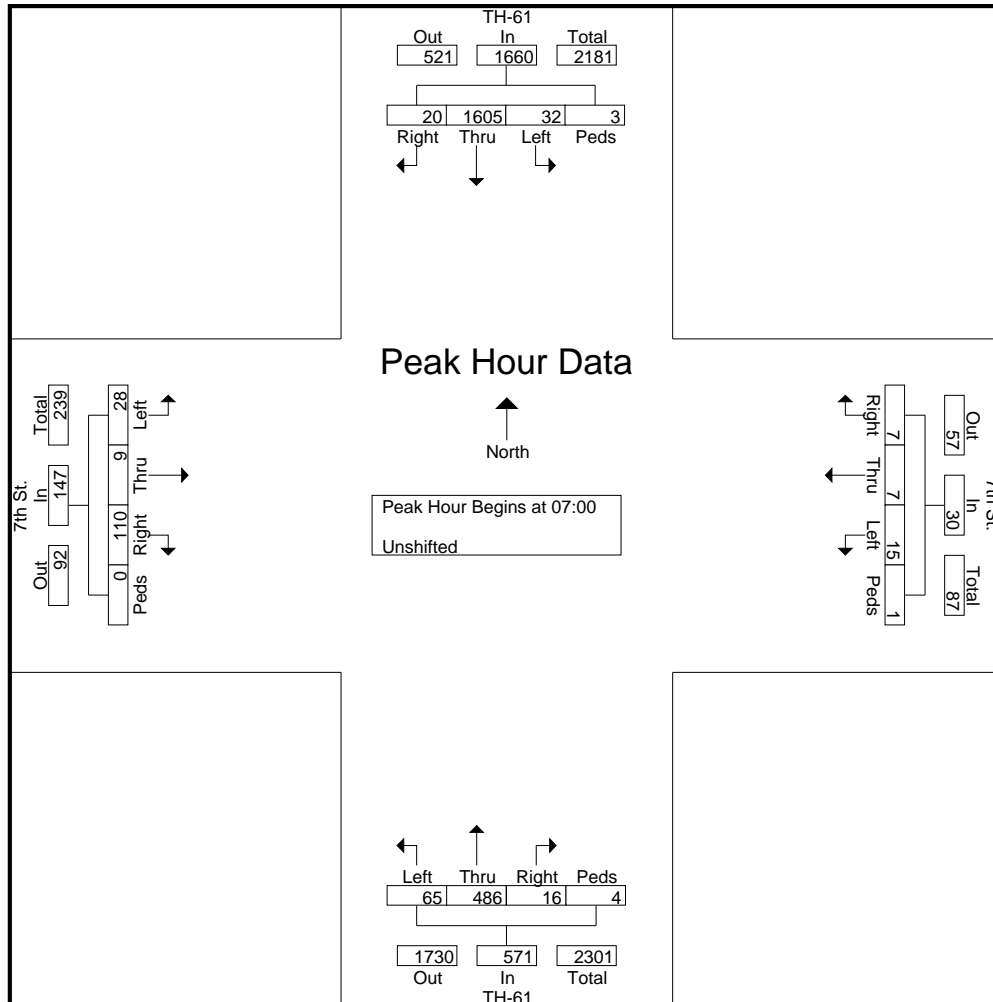



MINNESOTA DEPT OF TRANSPORTATION

TRAFFIC DATA COLLECTION - METRO

TH-61 at 7th St. (White Bear Lake)

Ref.Pt.: 147.471

Data by: Alliant Inc.

TURN MOVEMENT COUNT

File Name : TH-61 at 7th St WBL 2008

Site Code : 00000117

Start Date : 9/10/2008

Page No : 4

Start Time	TH-61 Southbound					7th St. Westbound					TH-61 Northbound					7th St. Eastbound					Int. Total
	Left	Thru	Right	Peds	App. Total	Left	Thru	Right	Peds	App. Total	Left	Thru	Right	Peds	App. Total	Left	Thru	Right	Peds	App. Total	

Peak Hour Analysis From 16:30 to 18:00 - Peak 1 of 1

Peak Hour for Entire Intersection Begins at 16:30

16:30	11	173	5	1	190	5	2	5	0	12	10	332	25	0	367	14	2	15	0	31	600
16:45	6	181	3	0	190	4	1	4	0	9	24	360	11	0	395	18	3	15	0	36	630
17:00	7	135	1	0	143	7	17	0	0	24	12	338	9	0	359	19	6	14	0	39	565
17:15	5	175	0	0	180	10	0	6	0	16	27	354	13	0	394	14	2	14	0	30	620
Total Volume	29	664	9	1	703	26	20	15	0	61	73	1384	58	0	1515	65	13	58	0	136	2415
% App. Total	4.1	94.5	1.3	0.1		42.6	32.8	24.6	0		4.8	91.4	3.8	0		47.8	9.6	42.6	0		
PHF	.659	.917	.450	.250	.925	.650	.294	.625	.000	.635	.676	.961	.580	.000	.959	.855	.542	.967	.000	.872	.958

