



MINNESOTA DEPT OF TRANSPORTATION

TRAFFIC DATA COLLECTION - METRO

TH-61 AT 7TH ST. (WHITE BEAR LAKE)
 REF.PT.: 147.471
 JAMAR # 631 RE
 TURN MOVEMENT COUNT

File Name : TH-61 AT 7TH ST 2007
 Site Code : 00000000
 Start Date : 9/20/2007
 Page No : 1

Groups Printed- Cars & Trucks

Start Time	TH-61 Southbound				7TH ST. Westbound				TH-61 Northbound				7TH ST. Eastbound				Int. Total
	Left	Thru	Right	Peds	Left	Thru	Right	Peds	Left	Thru	Right	Peds	Left	Thru	Right	Peds	
06:00	2	196	2	0	4	0	0	0	2	62	1	0	0	1	2	0	272
06:15	7	322	3	1	5	1	1	0	3	78	1	0	1	2	11	1	437
06:30	4	352	2	0	5	1	0	0	12	70	0	0	0	3	10	1	460
06:45	14	327	1	0	9	3	0	2	17	137	1	1	1	4	32	1	550
Total	27	1197	8	1	23	5	1	2	34	347	3	1	2	10	55	3	1719
07:00	8	460	4	0	10	5	2	2	35	107	0	0	4	9	52	1	699
07:15	6	401	9	0	4	3	1	1	17	122	6	0	6	10	49	0	635
07:30	10	355	11	0	9	2	0	0	8	147	3	0	2	3	9	0	559
07:45	15	382	8	0	8	2	1	1	7	144	0	0	4	2	16	0	590
Total	39	1598	32	0	31	12	4	4	67	520	9	0	16	24	126	1	2483
08:00	15	294	5	1	6	2	1	6	13	123	7	2	13	4	17	2	511
08:15	8	296	11	0	7	1	2	1	6	133	3	0	5	2	11	0	486
08:30	8	234	9	0	8	2	3	1	9	125	3	0	6	3	10	0	421
08:45	12	231	3	1	5	2	1	1	10	167	8	1	2	1	12	0	457
Total	43	1055	28	2	26	7	7	9	38	548	21	3	26	10	50	2	1875
*** BREAK ***																	
11:00	7	166	4	0	4	3	2	1	12	191	5	0	2	0	12	0	409
11:15	12	155	3	0	3	0	3	0	12	175	8	0	4	4	15	0	394
11:30	15	156	6	0	10	1	7	0	16	169	11	0	6	5	12	1	415
11:45	15	175	4	2	15	3	3	2	20	175	9	3	10	3	19	5	463
Total	49	652	17	2	32	7	15	3	60	710	33	3	22	12	58	6	1681
12:00	9	162	7	0	4	3	5	0	16	186	6	0	6	2	9	0	415
12:15	9	132	2	0	11	3	2	0	11	238	13	0	5	2	17	0	445
12:30	6	177	4	0	8	3	2	1	21	208	9	0	5	2	7	2	455
12:45	6	132	9	1	6	0	1	1	12	199	2	0	8	2	10	2	391
Total	30	603	22	1	29	9	10	2	60	831	30	0	24	8	43	4	1706
*** BREAK ***																	
14:45	6	154	8	0	9	3	3	4	31	265	6	0	15	9	19	9	541
Total	6	154	8	0	9	3	3	4	31	265	6	0	15	9	19	9	541
15:00	8	211	7	0	13	3	3	0	32	277	13	0	7	6	22	7	609
15:15	9	198	5	3	5	0	6	3	25	294	7	0	7	5	15	0	582
15:30	12	127	7	1	7	2	3	3	19	310	3	0	8	6	6	0	514
15:45	11	161	4	0	12	7	6	0	42	284	12	3	11	6	7	0	566
Total	40	697	23	4	37	12	18	6	118	1165	35	3	33	23	50	7	2271
16:00	9	190	5	0	6	4	6	0	28	320	16	0	6	5	14	2	611
16:15	16	192	4	0	11	4	3	0	29	346	15	0	8	3	11	1	643
16:30	7	188	2	0	7	7	3	0	27	339	2	0	10	9	15	2	618
16:45	11	175	3	0	12	6	2	0	24	392	12	0	11	12	13	1	674
Total	43	745	14	0	36	21	14	0	108	1397	45	0	35	29	53	6	2546
17:00	9	194	6	0	10	5	6	3	27	367	12	0	11	0	20	0	670
17:15	10	173	3	0	9	2	14	1	23	392	11	1	10	6	12	0	667
17:30	14	204	2	0	6	8	5	1	20	373	10	1	10	8	16	0	678
17:45	7	212	6	2	4	1	2	0	20	354	16	0	5	5	29	5	668
Total	40	783	17	2	29	16	27	5	90	1486	49	2	36	19	77	5	2683
Grand Total	317	7484	169	12	252	92	99	35	606	7269	231	12	209	144	531	43	17505
Apprch %	4	93.8	2.1	0.2	52.7	19.2	20.7	7.3	7.5	89.5	2.8	0.1	22.5	15.5	57.3	4.6	
Total %	1.8	42.8	1	0.1	1.4	0.5	0.6	0.2	3.5	41.5	1.3	0.1	1.2	0.8	3	0.2	



MINNESOTA DEPT OF TRANSPORTATION

TRAFFIC DATA COLLECTION - METRO

TH-61 AT 7TH ST. (WHITE BEAR LAKE)
 REF.PT.: 147.471
 JAMAR # 631 RE
 TURN MOVEMENT COUNT

File Name : TH-61 AT 7TH ST 2007
 Site Code : 00000000
 Start Date : 9/20/2007
 Page No : 3

Start Time	TH-61 Southbound					7TH ST. Westbound					TH-61 Northbound					7TH ST. Eastbound					Int. Total
	Left	Thru	Right	Peds	App. Total	Left	Thru	Right	Peds	App. Total	Left	Thru	Right	Peds	App. Total	Left	Thru	Right	Peds	App. Total	
Peak Hour Analysis From 06:00 to 08:45 - Peak 1 of 1																					
Peak Hour for Entire Intersection Begins at 07:00																					
07:00	8	460	4	0	472	10	5	2	2	19	35	107	0	0	142	4	9	52	1	66	699
07:15	6	401	9	0	416	4	3	1	1	9	17	122	6	0	145	6	10	49	0	65	635
07:30	10	355	11	0	376	9	2	0	0	11	8	147	3	0	158	2	3	9	0	14	559
07:45	15	382	8	0	405	8	2	1	1	12	7	144	0	0	151	4	2	16	0	22	590
Total Volume	39	1598	32	0	1669	31	12	4	4	51	67	520	9	0	596	16	24	126	1	167	2483
% App. Total	2.3	95.7	1.9	0		60.8	23.5	7.8	7.8		11.2	87.2	1.5	0		9.6	14.4	75.4	0.6		
PHF	.650	.868	.727	.000	.884	.775	.600	.500	.500	.671	.479	.884	.375	.000	.943	.667	.600	.606	.250	.633	.888

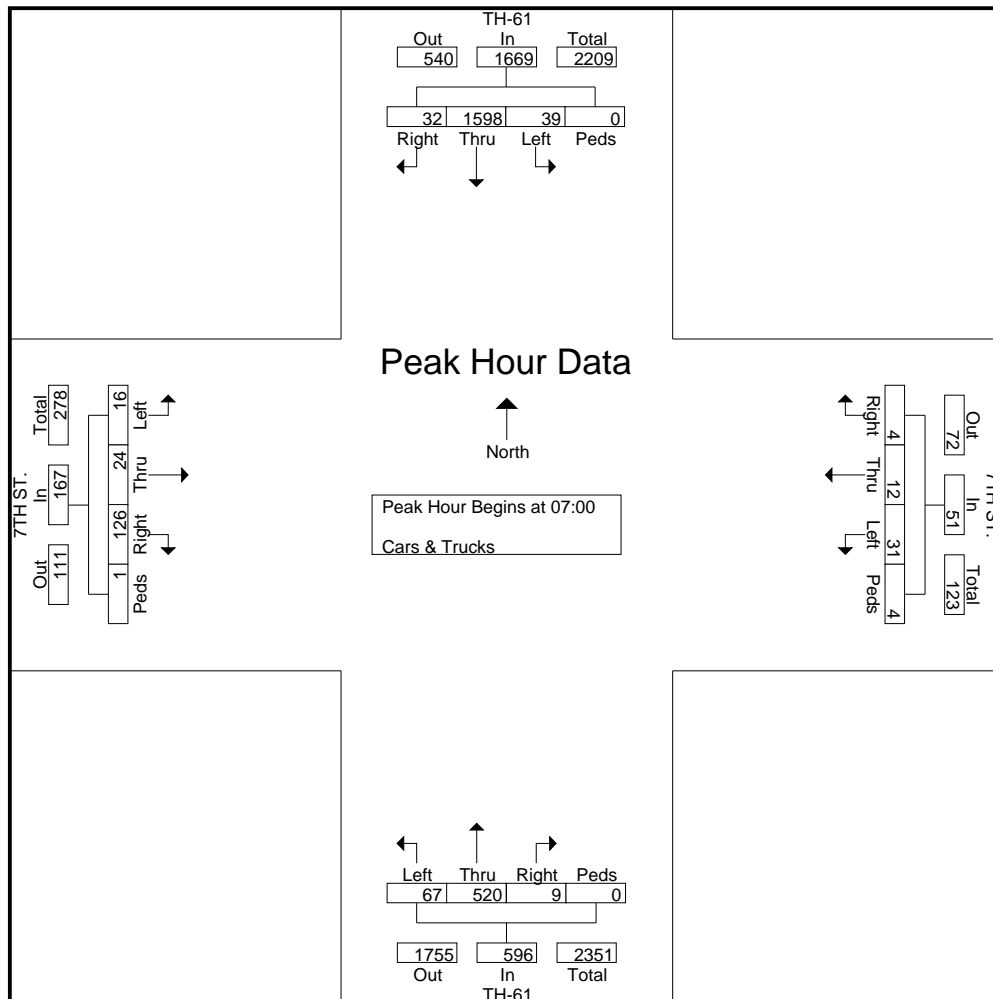



MINNESOTA DEPT OF TRANSPORTATION

TRAFFIC DATA COLLECTION - METRO

TH-61 AT 7TH ST. (WHITE BEAR LAKE)
 REF.PT.: 147.471
 JAMAR # 631 RE
 TURN MOVEMENT COUNT

File Name : TH-61 AT 7TH ST 2007
 Site Code : 00000000
 Start Date : 9/20/2007
 Page No : 4

Start Time	TH-61 Southbound					7TH ST. Westbound					TH-61 Northbound					7TH ST. Eastbound					Int. Total
	Left	Thru	Right	Peds	App. Total	Left	Thru	Right	Peds	App. Total	Left	Thru	Right	Peds	App. Total	Left	Thru	Right	Peds	App. Total	
Peak Hour Analysis From 15:00 to 17:45 - Peak 1 of 1																					
Peak Hour for Entire Intersection Begins at 16:45																					
16:45	11	175	3	0	189	12	6	2	0	20	24	392	12	0	428	11	12	13	1	37	674
17:00	9	194	6	0	209	10	5	6	3	24	27	367	12	0	406	11	0	20	0	31	670
17:15	10	173	3	0	186	9	2	14	1	26	23	392	11	1	427	10	6	12	0	28	667
17:30	14	204	2	0	220	6	8	5	1	20	20	373	10	1	404	10	8	16	0	34	678
Total Volume	44	746	14	0	804	37	21	27	5	90	94	1524	45	2	1665	42	26	61	1	130	2689
% App. Total	5.5	92.8	1.7	0		41.1	23.3	30	5.6		5.6	91.5	2.7	0.1		32.3	20	46.9	0.8		
PHF	.786	.914	.583	.000	.914	.771	.656	.482	.417	.865	.870	.972	.938	.500	.973	.955	.542	.763	.250	.878	.992

