



MINNESOTA DEPT OF TRANSPORTATION

TRAFFIC DATA COLLECTION - METRO

TH-61 at 4th St. (White Bear Lake)

Ref.Pt.: 147.244

Data by: Alliant Inc.

TURN MOVEMENT COUNT

File Name : TH-61 at 4th St WBL 2008

Site Code : 00000116

Start Date : 9/10/2008

Page No : 1

Groups Printed- Unshifted

Start Time	TH-61 Southbound				4th St. Westbound				TH-61 Northbound				4th St. Eastbound				Int. Total
	Left	Thru	Right	Peds	Left	Thru	Right	Peds	Left	Thru	Right	Peds	Left	Thru	Right	Peds	
06:00	0	150	5	0	6	1	0	0	3	65	1	0	5	0	19	0	255
06:15	0	222	7	0	12	1	0	0	11	54	1	0	9	1	26	0	344
06:30	0	291	11	0	13	4	0	0	8	64	4	0	12	1	34	1	443
06:45	0	318	24	0	9	0	0	0	14	110	6	0	13	3	34	1	532
Total	0	981	47	0	40	6	0	0	36	293	12	0	39	5	113	2	1574
07:00	1	365	19	2	19	12	0	0	29	145	3	0	21	6	65	0	687
07:15	1	454	25	0	17	14	1	0	16	136	10	0	14	8	78	0	774
07:30	3	367	25	2	15	10	2	0	27	110	10	0	14	7	36	0	628
07:45	1	382	30	1	20	19	1	0	20	128	13	0	18	12	51	2	698
Total	6	1568	99	5	71	55	4	0	92	519	36	0	67	33	230	2	2787
08:00	2	257	21	1	15	8	1	0	20	115	9	0	16	8	24	0	497
08:15	2	216	18	0	12	8	3	0	22	123	12	0	16	13	25	0	470
08:30	2	225	20	2	28	9	3	0	20	120	16	0	18	7	33	1	504
08:45	2	220	23	0	16	10	3	0	30	157	20	0	24	19	26	0	550
Total	8	918	82	3	71	35	10	0	92	515	57	0	74	47	108	1	2021
09:00	6	157	13	1	27	12	0	0	18	125	20	0	17	10	27	1	434
09:15	6	171	28	0	26	13	1	0	18	128	20	0	15	12	23	0	461
*** BREAK ***																	
Total	12	328	41	1	53	25	1	0	36	253	40	0	32	22	50	1	895
*** BREAK ***																	
10:30	5	117	12	3	23	26	0	0	30	131	22	0	26	5	30	1	431
10:45	4	159	17	4	23	13	5	0	21	168	16	0	19	11	22	0	482
Total	9	276	29	7	46	39	5	0	51	299	38	0	45	16	52	1	913
11:00	3	135	18	0	21	9	5	0	27	196	23	0	14	15	30	1	497
11:15	6	157	15	6	42	15	2	0	24	179	36	0	19	9	29	5	544
11:30	4	124	20	1	20	13	2	0	34	183	27	0	21	10	33	1	493
11:45	4	130	12	1	32	16	1	0	30	172	22	0	16	9	35	0	480
Total	17	546	65	8	115	53	10	0	115	730	108	0	70	43	127	7	2014
12:00	6	87	23	1	29	15	2	0	41	192	24	0	31	17	38	2	508
12:15	4	163	18	2	27	25	6	0	26	164	24	0	23	16	38	0	536
12:30	3	145	11	1	22	19	5	0	43	169	38	0	25	14	42	0	537
12:45	4	147	13	3	32	18	4	0	36	152	24	0	20	14	35	0	502
Total	17	542	65	7	110	77	17	0	146	677	110	0	99	61	153	2	2083
13:00	0	119	12	0	34	8	4	0	36	187	22	0	21	15	26	0	484
13:15	1	132	14	0	28	16	1	0	50	180	17	0	23	14	40	0	516
*** BREAK ***																	
Total	1	251	26	0	62	24	5	0	86	367	39	0	44	29	66	0	1000
*** BREAK ***																	
14:30	0	92	9	0	23	55	2	0	33	184	15	0	18	16	29	0	476
14:45	0	172	18	1	20	11	0	0	55	283	32	0	23	6	34	0	655
Total	0	264	27	1	43	66	2	0	88	467	47	0	41	22	63	0	1131
15:00	0	148	11	3	27	23	8	1	56	261	23	3	26	8	30	1	629
15:15	0	122	19	0	36	28	0	4	39	256	29	4	28	18	26	0	609
15:30	0	133	7	0	24	22	2	2	53	271	25	9	29	27	32	0	636
15:45	0	138	21	1	25	22	3	4	56	268	21	4	25	26	33	0	647
Total	0	541	58	4	112	95	13	11	204	1056	98	20	108	79	121	1	2521



MINNESOTA DEPT OF TRANSPORTATION

TRAFFIC DATA COLLECTION - METRO

TH-61 at 4th St. (White Bear Lake)

Ref.Pt.: 147.244

Data by: Alliant Inc.

TURN MOVEMENT COUNT

File Name : TH-61 at 4th St WBL 2008

Site Code : 00000116

Start Date : 9/10/2008

Page No : 2

Groups Printed- Unshifted

Start Time	TH-61 Southbound				4th St. Westbound				TH-61 Northbound				4th St. Eastbound				Int. Total
	Left	Thru	Right	Peds	Left	Thru	Right	Peds	Left	Thru	Right	Peds	Left	Thru	Right	Peds	
16:00	6	154	12	0	33	23	1	2	68	268	21	0	32	21	34	0	675
16:15	2	140	16	1	24	35	2	1	47	282	21	2	22	23	24	1	643
16:30	6	158	16	0	32	24	1	0	62	289	27	1	30	19	43	0	708
16:45	3	173	26	3	15	25	5	1	47	332	25	10	38	17	27	0	747
Total	17	625	70	4	104	107	9	4	224	1171	94	13	122	80	128	1	2773
17:00	0	163	13	3	26	21	2	0	27	340	23	3	35	20	39	1	716
17:15	1	180	12	0	27	16	2	2	70	330	17	2	27	6	32	1	725
17:30	1	170	20	4	14	15	3	0	47	297	20	3	33	10	33	0	670
17:45	3	201	22	0	15	26	0	0	49	275	27	5	36	16	44	0	719
Total	5	714	67	7	82	78	7	2	193	1242	87	13	131	52	148	2	2830
Grand Total	92	7554	676	47	909	660	83	17	1363	7589	766	46	872	489	1359	20	22542
Apprch %	1.1	90.3	8.1	0.6	54.5	39.5	5	1	14	77.7	7.8	0.5	31.8	17.8	49.6	0.7	
Total %	0.4	33.5	3	0.2	4	2.9	0.4	0.1	6	33.7	3.4	0.2	3.9	2.2	6	0.1	



MINNESOTA DEPT OF TRANSPORTATION

TRAFFIC DATA COLLECTION - METRO

TH-61 at 4th St. (White Bear Lake)

Ref.Pt.: 147.244

Data by: Alliant Inc.

TURN MOVEMENT COUNT

File Name : TH-61 at 4th St WBL 2008

Site Code : 00000116

Start Date : 9/10/2008

Page No : 3

Start Time	TH-61 Southbound					4th St. Westbound					TH-61 Northbound					4th St. Eastbound					Int. Total
	Left	Thru	Right	Peds	App. Total	Left	Thru	Right	Peds	App. Total	Left	Thru	Right	Peds	App. Total	Left	Thru	Right	Peds	App. Total	
Peak Hour Analysis From 06:00 to 09:15 - Peak 1 of 1																					
Peak Hour for Entire Intersection Begins at 07:00																					
07:00	1	365	19	2	387	19	12	0	0	31	29	145	3	0	177	21	6	65	0	92	687
07:15	1	454	25	0	480	17	14	1	0	32	16	136	10	0	162	14	8	78	0	100	774
07:30	3	367	25	2	397	15	10	2	0	27	27	110	10	0	147	14	7	36	0	57	628
07:45	1	382	30	1	414	20	19	1	0	40	20	128	13	0	161	18	12	51	2	83	698
Total Volume	6	1568	99	5	1678	71	55	4	0	130	92	519	36	0	647	67	33	230	2	332	2787
% App. Total	0.4	93.4	5.9	0.3		54.6	42.3	3.1	0		14.2	80.2	5.6	0		20.2	9.9	69.3	0.6		
PHF	.500	.863	.825	.625	.874	.888	.724	.500	.000	.813	.793	.895	.692	.000	.914	.798	.688	.737	.250	.830	.900

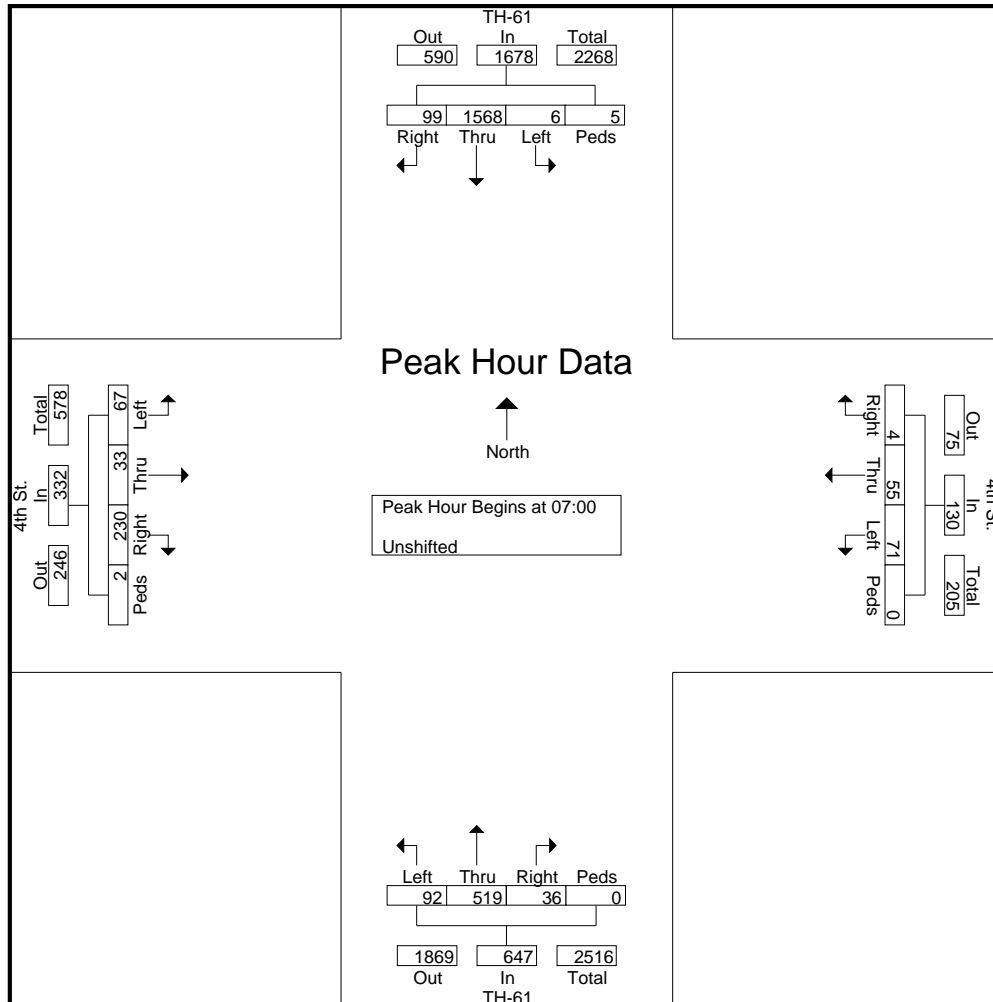



MINNESOTA DEPT OF TRANSPORTATION

TRAFFIC DATA COLLECTION - METRO

TH-61 at 4th St. (White Bear Lake)

Ref.Pt.: 147.244

Data by: Alliant Inc.

TURN MOVEMENT COUNT

File Name : TH-61 at 4th St WBL 2008

Site Code : 00000116

Start Date : 9/10/2008

Page No : 4

Start Time	TH-61 Southbound					4th St. Westbound					TH-61 Northbound					4th St. Eastbound					Int. Total
	Left	Thru	Right	Peds	App. Total	Left	Thru	Right	Peds	App. Total	Left	Thru	Right	Peds	App. Total	Left	Thru	Right	Peds	App. Total	

Peak Hour Analysis From 14:30 to 17:45 - Peak 1 of 1

Peak Hour for Entire Intersection Begins at 16:30

16:30	6	158	16	0	180	32	24	1	0	57	62	289	27	1	379	30	19	43	0	92	708
16:45	3	173	26	3	205	15	25	5	1	46	47	332	25	10	414	38	17	27	0	82	747
17:00	0	163	13	3	179	26	21	2	0	49	27	340	23	3	393	35	20	39	1	95	716
17:15	1	180	12	0	193	27	16	2	2	47	70	330	17	2	419	27	6	32	1	66	725
Total Volume	10	674	67	6	757	100	86	10	3	199	206	1291	92	16	1605	130	62	141	2	335	2896
% App. Total	1.3	89	8.9	0.8		50.3	43.2	5	1.5		12.8	80.4	5.7	1		38.8	18.5	42.1	0.6		
PHF	.417	.936	.644	.500	.923	.781	.860	.500	.375	.873	.736	.949	.852	.400	.958	.855	.775	.820	.500	.882	.969

