



MINNESOTA DEPT OF TRANSPORTATION

TRAFFIC DATA COLLECTION - METRO

TH-61 at 2nd St. (White Bear Lake)

Ref.Pt.: 147.075

Data by: Alliant Inc.

TURN MOVEMENT COUNT

File Name : TH-61 at 2nd St WBL 2008

Site Code : 00000115

Start Date : 9/9/2008

Page No : 1

Groups Printed- Unshifted

Start Time	TH-61 Southbound				2nd St. Westbound				TH-61 Northbound				2nd St. Eastbound				Int. Total
	Left	Thru	Right	Peds	Left	Thru	Right	Peds	Left	Thru	Right	Peds	Left	Thru	Right	Peds	
06:00	1	169	0	0	7	0	0	0	2	58	2	1	0	0	7	0	247
06:15	0	258	2	0	2	0	0	0	4	67	1	0	0	0	8	0	342
06:30	0	320	1	0	2	0	0	1	5	98	2	0	1	0	13	0	443
06:45	0	365	4	0	3	0	0	0	3	118	5	0	1	2	16	0	517
Total	1	1112	7	0	14	0	0	1	14	341	10	1	2	2	44	0	1549
07:00	0	453	8	0	7	1	1	1	13	162	3	0	0	2	43	0	694
07:15	0	508	19	0	2	2	2	0	13	169	3	0	12	3	53	0	786
07:30	0	399	12	0	4	1	0	0	10	134	7	0	3	1	23	0	594
07:45	2	429	8	0	7	4	1	0	21	155	12	0	1	2	18	0	660
Total	2	1789	47	0	20	8	4	1	57	620	25	0	16	8	137	0	2734
08:00	0	301	5	0	6	2	2	0	19	138	6	0	0	1	23	0	503
08:15	0	249	3	0	10	3	1	1	10	155	7	0	2	2	15	0	458
08:30	0	214	1	0	5	4	0	0	9	150	6	0	4	2	28	0	423
08:45	3	245	4	0	12	2	1	1	17	202	8	2	3	3	21	0	524
Total	3	1009	13	0	33	11	4	2	55	645	27	2	9	8	87	0	1908
09:00	1	222	5	0	9	8	2	1	19	160	16	1	5	3	18	0	470
09:15	1	209	3	0	18	2	0	0	17	163	13	0	3	2	20	0	451
*** BREAK ***																	
Total	2	431	8	0	27	10	2	1	36	323	29	1	8	5	38	0	921
*** BREAK ***																	
10:30	3	147	5	0	12	4	0	0	18	169	17	0	1	3	24	0	403
10:45	1	161	6	0	20	1	0	3	24	209	20	0	3	6	13	0	467
Total	4	308	11	0	32	5	0	3	42	378	37	0	4	9	37	0	870
11:00	1	136	8	0	14	6	2	0	20	181	23	1	2	2	30	0	426
11:15	0	190	4	0	20	3	2	0	20	227	21	0	2	3	15	0	507
11:30	3	164	3	0	21	3	2	0	22	214	20	1	5	2	18	0	478
11:45	2	184	8	0	17	8	2	0	27	251	20	0	4	3	24	0	550
Total	6	674	23	0	72	20	8	0	89	873	84	2	13	10	87	0	1961
12:00	2	145	5	0	26	5	2	0	29	234	19	1	5	5	20	0	498
12:15	4	209	6	0	17	7	3	0	20	243	20	0	2	4	30	0	565
12:30	1	189	8	0	23	11	3	0	24	242	20	2	7	6	25	0	561
12:45	2	213	9	0	21	1	1	3	27	233	18	1	2	0	24	0	555
Total	9	756	28	0	87	24	9	3	100	952	77	4	16	15	99	0	2179
13:00	6	175	10	0	24	6	1	0	23	225	22	3	5	7	36	0	543
13:15	2	184	9	0	20	5	0	0	15	233	16	1	3	5	15	0	508
*** BREAK ***																	
Total	8	359	19	0	44	11	1	0	38	458	38	4	8	12	51	0	1051
*** BREAK ***																	
14:30	1	168	4	0	14	6	1	2	14	270	21	3	5	1	24	3	537
14:45	2	206	3	0	29	5	2	6	23	423	28	0	3	0	22	0	752
Total	3	374	7	0	43	11	3	8	37	693	49	3	8	1	46	3	1289
15:00	5	212	4	1	27	5	1	2	30	363	21	1	0	3	33	1	709
15:15	0	189	4	3	18	1	2	1	28	330	18	0	6	2	20	0	622
15:30	3	180	7	3	29	2	3	1	17	382	27	1	6	2	16	0	679
15:45	0	234	6	1	25	3	3	2	35	321	38	1	6	3	24	0	702
Total	8	815	21	8	99	11	9	6	110	1396	104	3	18	10	93	1	2712



MINNESOTA DEPT OF TRANSPORTATION

TRAFFIC DATA COLLECTION - METRO

TH-61 at 2nd St. (White Bear Lake)

Ref.Pt.: 147.075

Data by: Alliant Inc.

TURN MOVEMENT COUNT

File Name : TH-61 at 2nd St WBL 2008

Site Code : 00000115

Start Date : 9/9/2008

Page No : 2

Groups Printed- Unshifted

Start Time	TH-61 Southbound				2nd St. Westbound				TH-61 Northbound				2nd St. Eastbound				Int. Total
	Left	Thru	Right	Peds	Left	Thru	Right	Peds	Left	Thru	Right	Peds	Left	Thru	Right	Peds	
16:00	3	226	8	0	25	7	0	1	27	361	26	1	7	7	36	0	735
16:15	1	222	4	1	22	3	1	0	33	368	38	1	5	3	26	0	728
16:30	0	244	3	2	11	8	4	0	22	368	16	1	9	2	42	0	732
16:45	0	233	3	0	17	7	0	5	22	404	20	0	11	2	27	0	751
Total	4	925	18	3	75	25	5	6	104	1501	100	3	32	14	131	0	2946
17:00	0	248	5	0	10	10	5	1	41	449	31	6	1	1	20	0	828
17:15	1	234	5	1	13	6	0	0	40	390	29	3	3	4	22	0	751
17:30	1	218	2	0	20	6	6	0	28	404	25	2	4	1	11	0	728
17:45	0	195	1	1	17	8	4	0	22	406	23	2	0	2	22	0	703
Total	2	895	13	2	60	30	15	1	131	1649	108	13	8	8	75	0	3010
Grand Total	52	9447	215	13	606	166	60	32	813	9829	688	36	142	102	925	4	23130
Apprch %	0.5	97.1	2.2	0.1	70.1	19.2	6.9	3.7	7.2	86.5	6.1	0.3	12.1	8.7	78.9	0.3	
Total %	0.2	40.8	0.9	0.1	2.6	0.7	0.3	0.1	3.5	42.5	3	0.2	0.6	0.4	4	0	



MINNESOTA DEPT OF TRANSPORTATION

TRAFFIC DATA COLLECTION - METRO

TH-61 at 2nd St. (White Bear Lake)

Ref.Pt.: 147.075

Data by: Alliant Inc.

TURN MOVEMENT COUNT

File Name : TH-61 at 2nd St WBL 2008

Site Code : 00000115

Start Date : 9/9/2008

Page No : 3

Start Time	TH-61 Southbound					2nd St. Westbound					TH-61 Northbound					2nd St. Eastbound					Int. Total
	Left	Thru	Right	Peds	App. Total	Left	Thru	Right	Peds	App. Total	Left	Thru	Right	Peds	App. Total	Left	Thru	Right	Peds	App. Total	
Peak Hour Analysis From 06:00 to 09:15 - Peak 1 of 1																					
Peak Hour for Entire Intersection Begins at 07:00																					
07:00	0	453	8	0	461	7	1	1	1	10	13	162	3	0	178	0	2	43	0	45	694
07:15	0	508	19	0	527	2	2	2	0	6	13	169	3	0	185	12	3	53	0	68	786
07:30	0	399	12	0	411	4	1	0	0	5	10	134	7	0	151	3	1	23	0	27	594
07:45	2	429	8	0	439	7	4	1	0	12	21	155	12	0	188	1	2	18	0	21	660
Total Volume	2	1789	47	0	1838	20	8	4	1	33	57	620	25	0	702	16	8	137	0	161	2734
% App. Total	0.1	97.3	2.6	0		60.6	24.2	12.1	3		8.1	88.3	3.6	0		9.9	5	85.1	0		
PHF	.250	.880	.618	.000	.872	.714	.500	.500	.250	.688	.679	.917	.521	.000	.934	.333	.667	.646	.000	.592	.870

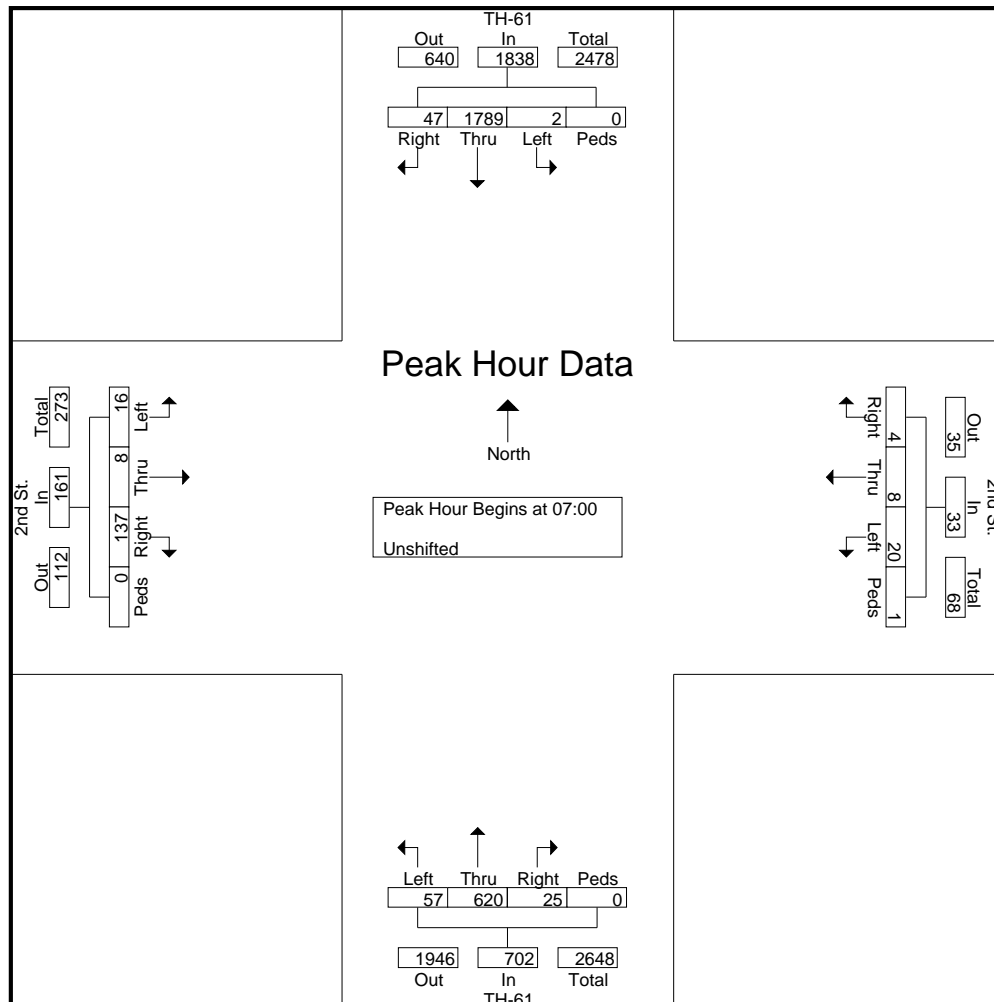



MINNESOTA DEPT OF TRANSPORTATION

TRAFFIC DATA COLLECTION - METRO

TH-61 at 2nd St. (White Bear Lake)

Ref.Pt.: 147.075

Data by: Alliant Inc.

TURN MOVEMENT COUNT

File Name : TH-61 at 2nd St WBL 2008

Site Code : 00000115

Start Date : 9/9/2008

Page No : 4

Start Time	TH-61 Southbound					2nd St. Westbound					TH-61 Northbound					2nd St. Eastbound					Int. Total
	Left	Thru	Right	Peds	App. Total	Left	Thru	Right	Peds	App. Total	Left	Thru	Right	Peds	App. Total	Left	Thru	Right	Peds	App. Total	

Peak Hour Analysis From 14:30 to 17:45 - Peak 1 of 1

Peak Hour for Entire Intersection Begins at 16:30

16:30	0	244	3	2	249	11	8	4	0	23	22	368	16	1	407	9	2	42	0	53	732
16:45	0	233	3	0	236	17	7	0	5	29	22	404	20	0	446	11	2	27	0	40	751
17:00	0	248	5	0	253	10	10	5	1	26	41	449	31	6	527	1	1	20	0	22	828
17:15	1	234	5	1	241	13	6	0	0	19	40	390	29	3	462	3	4	22	0	29	751
Total Volume	1	959	16	3	979	51	31	9	6	97	125	1611	96	10	1842	24	9	111	0	144	3062
% App. Total	0.1	98	1.6	0.3		52.6	32	9.3	6.2		6.8	87.5	5.2	0.5		16.7	6.2	77.1	0		
PHF	.250	.967	.800	.375	.967	.750	.775	.450	.300	.836	.762	.897	.774	.417	.874	.545	.563	.661	.000	.679	.925

