

Alliant Engineering Inc Minneapolis, MN 55415

TH-61 at CSAH-96
Ref.Pt.: 146.726
Data by Alliant Engineering
TURN MOVEMENT COUNT

File Name : TH-61 at CSAH-96 2008
Site Code : 00000114
Start Date : 9/9/2008
Page No : 1

Groups Printed- Unshifted - Bank 1

Start Time	TH-61 Southbound				Lake Avenue N - (one way WB) Westbound				TH-61 Northbound				CSAH-96 Eastbound				Int. Total
	Left	Thru	Right	Peds	Left	Thru	Right	Peds	Left	Thru	Right	Peds	Left	Thru	Right	Peds	
06:00	0	137	41	0	5	0	2	0	18	35	0	1	27	0	17	0	283
06:15	0	204	70	0	12	2	0	0	16	53	1	0	27	0	24	0	409
06:30	1	248	71	2	13	8	1	0	30	76	0	0	32	0	44	0	526
06:45	0	323	85	0	18	10	0	0	36	90	0	1	53	0	58	0	674
Total	1	912	267	2	48	20	3	0	100	254	1	2	139	0	143	0	1892
07:00	0	376	89	0	22	14	1	1	32	150	0	0	45	0	76	0	806
07:15	0	485	95	0	35	13	1	0	44	148	0	0	65	0	94	0	980
07:30	0	358	107	0	31	14	0	0	38	102	0	1	53	0	94	1	799
07:45	0	349	117	0	30	17	3	0	54	164	0	0	54	0	91	0	879
Total	0	1568	408	0	118	58	5	1	168	564	0	1	217	0	355	1	3464
08:00	0	257	106	0	40	9	0	0	49	117	0	1	64	0	56	0	699
08:15	0	223	106	0	16	13	0	2	46	120	0	0	72	0	63	0	661
08:30	0	190	64	0	31	15	0	0	41	132	0	0	40	8	57	0	578
08:45	0	194	85	1	22	25	0	2	48	136	0	1	102	0	67	0	683
Total	0	864	361	1	109	62	0	4	184	505	0	2	278	8	243	0	2621
09:00	0	190	91	0	30	13	0	1	39	148	0	1	72	0	47	0	632
09:15	0	184	77	0	37	13	0	1	55	156	0	0	78	0	56	0	657
*** BREAK ***																	
Total	0	374	168	0	67	26	0	2	94	304	0	1	150	0	103	0	1289
*** BREAK ***																	
10:30	0	170	79	0	29	11	1	0	38	151	2	0	92	0	50	0	623
10:45	0	131	57	0	19	3	2	0	47	155	0	0	80	0	30	0	524
Total	0	301	136	0	48	14	3	0	85	306	2	0	172	0	80	0	1147
11:00	0	139	57	0	32	12	2	0	41	164	0	2	86	1	44	0	580
11:15	0	133	102	1	26	14	1	0	65	190	0	0	78	0	65	0	675
11:30	0	183	66	0	25	15	1	0	45	159	0	0	97	0	40	0	631
11:45	0	168	78	0	23	9	2	0	49	233	0	0	85	0	80	0	727
Total	0	623	303	1	106	50	6	0	200	746	0	2	346	1	229	0	2613
12:00	0	131	80	2	38	19	1	0	68	215	0	0	79	1	60	0	694
12:15	0	181	84	0	26	12	3	0	72	203	0	0	98	0	62	0	741
12:30	0	184	74	0	42	15	4	2	51	211	0	0	108	0	76	0	767
12:45	0	202	79	0	23	13	3	1	72	204	1	0	86	1	60	0	745
Total	0	698	317	2	129	59	11	3	263	833	1	0	371	2	258	0	2947
13:00	0	187	76	2	20	14	1	0	44	194	0	1	94	1	48	0	682
13:15	0	181	75	2	26	15	2	2	53	234	0	0	69	0	42	0	701
*** BREAK ***																	
Total	0	368	151	4	46	29	3	2	97	428	0	1	163	1	90	0	1383
*** BREAK ***																	
14:30	0	195	82	0	37	15	3	1	72	229	27	2	94	0	49	0	806
14:45	0	197	99	1	42	12	5	1	79	398	0	1	135	24	59	0	1053
Total	0	392	181	1	79	27	8	2	151	627	27	3	229	24	108	0	1859
15:00	0	192	64	0	30	18	3	0	71	335	0	5	111	0	42	1	872
15:15	2	180	72	0	24	16	1	0	87	350	0	3	78	0	72	2	887
15:30	0	169	83	1	37	12	1	0	88	396	0	2	94	0	59	1	943
15:45	0	208	85	0	24	12	1	0	101	323	0	2	148	0	75	0	979
Total	2	749	304	1	115	58	6	0	347	1404	0	12	431	0	248	4	3681

Alliant Engineering Inc Minneapolis, MN 55415

TH-61 at CSAH-96
Ref.Pt.: 146.726
Data by Alliant Engineering
TURN MOVEMENT COUNT

File Name : TH-61 at CSAH-96 2008
Site Code : 00000114
Start Date : 9/9/2008
Page No : 2

Groups Printed- Unshifted - Bank 1

Start Time	TH-61 Southbound				Lake Avenue N - (one way WB) Westbound				TH-61 Northbound				CSAH-96 Eastbound				Int. Total
	Left	Thru	Right	Peds	Left	Thru	Right	Peds	Left	Thru	Right	Peds	Left	Thru	Right	Peds	
16:00	0	219	71	0	43	17	2	0	101	341	0	3	132	0	68	0	997
16:15	0	212	68	1	34	11	4	0	85	322	0	4	143	0	94	0	978
16:30	0	228	66	0	48	19	3	0	79	316	0	4	120	0	73	3	959
16:45	0	222	71	1	33	14	3	0	115	329	42	3	145	0	77	3	1058
Total	0	881	276	2	158	61	12	0	380	1308	42	14	540	0	312	6	3992
17:00	0	195	68	1	41	14	2	0	90	358	0	1	138	0	67	1	976
17:15	0	220	65	1	41	14	2	0	108	367	0	1	102	0	61	0	982
17:30	0	174	75	0	31	8	2	0	90	375	0	2	112	1	83	0	953
17:45	0	187	61	0	27	16	1	0	94	344	0	3	104	0	65	3	905
Total	0	776	269	2	140	52	7	0	382	1444	0	7	456	1	276	4	3816
18:00	0	200	67	0	32	20	3	0	90	330	0	0	112	0	38	0	892
Grand Total	3	8706	3208	16	1195	536	67	14	2541	9053	73	45	3604	37	2483	15	31596
Apprch %	0	73	26.9	0.1	65.9	29.6	3.7	0.8	21.7	77.3	0.6	0.4	58.7	0.6	40.4	0.2	
Total %	0	27.6	10.2	0.1	3.8	1.7	0.2	0	8	28.7	0.2	0.1	11.4	0.1	7.9	0	
Unshifted	3	8531	3148	15	1188	530	59	14	2500	8892	72	45	3549	37	2458	15	31056
% Unshifted	100	98	98.1	93.8	99.4	98.9	88.1	100	98.4	98.2	98.6	100	98.5	100	99	100	98.3
Bank 1	0	175	60	1	7	6	8	0	41	161	1	0	55	0	25	0	540
% Bank 1	0	2	1.9	6.2	0.6	1.1	11.9	0	1.6	1.8	1.4	0	1.5	0	1	0	1.7

Alliant Engineering Inc Minneapolis, MN 55415

TH-61 at CSAH-96
Ref.Pt.: 146.726
Data by Alliant Engineering
TURN MOVEMENT COUNT

File Name : TH-61 at CSAH-96 2008
Site Code : 00000114
Start Date : 9/9/2008
Page No : 3

Start Time	TH-61 Southbound					Lake Avenue N - (one way WB) Westbound					TH-61 Northbound					CSAH-96 Eastbound					Int. Total
	Left	Thru	Right	Peds	App. Total	Left	Thru	Right	Peds	App. Total	Left	Thru	Right	Peds	App. Total	Left	Thru	Right	Peds	App. Total	
Peak Hour Analysis From 06:00 to 09:15 - Peak 1 of 1																					
Peak Hour for Entire Intersection Begins at 07:00																					
07:00	0	376	89	0	465	22	14	1	1	38	32	150	0	0	182	45	0	76	0	121	806
07:15	0	485	95	0	580	35	13	1	0	49	44	148	0	0	192	65	0	94	0	159	980
07:30	0	358	107	0	465	31	14	0	0	45	38	102	0	1	141	53	0	94	1	148	799
07:45	0	349	117	0	466	30	17	3	0	50	54	164	0	0	218	54	0	91	0	145	879
Total Volume	0	1568	408	0	1976	118	58	5	1	182	168	564	0	1	733	217	0	355	1	573	3464
% App. Total	0	79.4	20.6	0		64.8	31.9	2.7	0.5		22.9	76.9	0	0.1		37.9	0	62	0.2		
PHF	.000	.808	.872	.000	.852	.843	.853	.417	.250	.910	.778	.860	.000	.250	.841	.835	.000	.944	.250	.901	.884

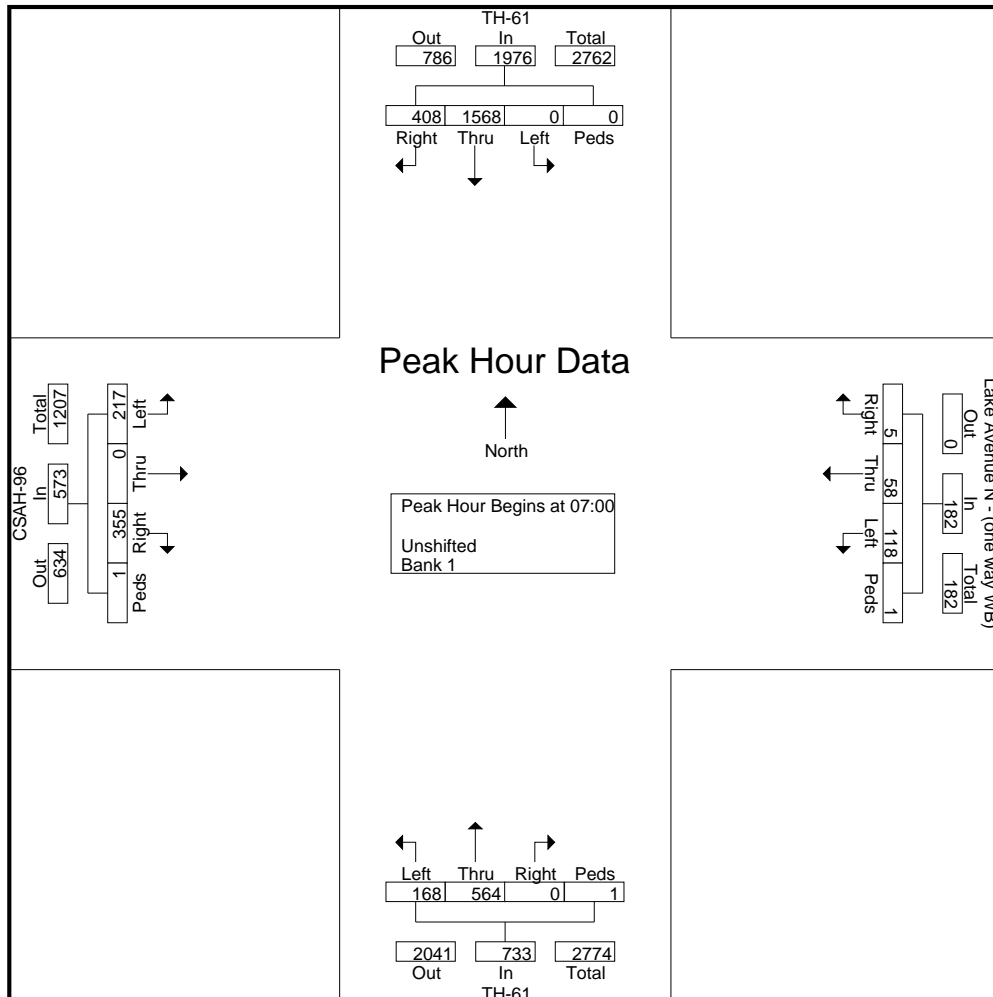

Alliant Engineering Inc Minneapolis, MN 55415

TH-61 at CSAH-96
Ref.Pt.: 146.726
Data by Alliant Engineering
TURN MOVEMENT COUNT

File Name : TH-61 at CSAH-96 2008
Site Code : 00000114
Start Date : 9/9/2008
Page No : 4

Start Time	TH-61 Southbound					Lake Avenue N - (one way WB) Westbound					TH-61 Northbound					CSAH-96 Eastbound					Int. Total
	Left	Thru	Right	Peds	App. Total	Left	Thru	Right	Peds	App. Total	Left	Thru	Right	Peds	App. Total	Left	Thru	Right	Peds	App. Total	
Peak Hour Analysis From 14:30 to 18:00 - Peak 1 of 1																					
Peak Hour for Entire Intersection Begins at 16:00																					
16:00	0	219	71	0	290	43	17	2	0	62	101	341	0	3	445	132	0	68	0	200	997
16:15	0	212	68	1	281	34	11	4	0	49	85	322	0	4	411	143	0	94	0	237	978
16:30	0	228	66	0	294	48	19	3	0	70	79	316	0	4	399	120	0	73	3	196	959
16:45	0	222	71	1	294	33	14	3	0	50	115	329	42	3	489	145	0	77	3	225	1058
Total Volume	0	881	276	2	1159	158	61	12	0	231	380	1308	42	14	1744	540	0	312	6	858	3992
% App. Total	0	76	23.8	0.2		68.4	26.4	5.2	0		21.8	75	2.4	0.8		62.9	0	36.4	0.7		
PHF	.000	.966	.972	.500	.986	.823	.803	.750	.000	.825	.826	.959	.250	.875	.892	.931	.000	.830	.500	.905	.943

