



MINNESOTA DEPT OF TRANSPORTATION

TRAFFIC DATA COLLECTION - METRO

TH-61 AT CSAH-96 / LAKE DRIVE (WBL)
 REF.PT.: 146.726
 JAMAR # 632 DR
 TURN MOVEMENT COUNT

File Name : TH-61 AT CSAH-96 LAKE DR 2007
 Site Code : 00000000
 Start Date : 9/20/2007
 Page No : 1

Groups Printed- Cars & Trucks

Start Time	TH-61 Southbound				LAKE DRIVE Westbound				TH-61 Northbound				CSAH-96 Eastbound				Int. Total
	Left	Thru	Right	Peds	Left	Thru	Right	Peds	Left	Thru	Right	Peds	Left	Thru	Right	Peds	
06:00	0	193	36	0	2	1	0	0	21	55	0	0	25	0	40	0	373
06:15	0	308	81	0	7	5	0	0	25	56	0	0	30	0	88	0	600
06:30	0	308	88	0	7	3	0	0	49	71	0	0	59	0	137	0	722
06:45	0	396	75	0	12	5	0	0	53	129	0	0	59	0	172	0	901
Total	0	1205	280	0	28	14	0	0	148	311	0	0	173	0	437	0	2596
07:00	0	482	101	0	20	8	0	0	42	139	0	0	80	0	203	0	1075
07:15	0	576	59	0	9	0	0	0	58	125	0	0	62	0	276	0	1165
07:30	0	457	114	0	0	0	2	0	89	136	0	0	84	0	209	1	1092
07:45	0	365	100	0	4	0	0	0	67	135	0	0	96	0	216	0	983
Total	0	1880	374	0	33	8	2	0	256	535	0	0	322	0	904	1	4315
08:00	0	310	100	0	1	1	0	0	82	139	1	0	102	0	237	2	975
08:15	0	302	102	0	4	0	0	0	45	125	0	0	96	0	210	0	884
08:30	0	283	78	0	0	0	0	0	42	138	0	0	99	0	136	0	776
08:45	0	254	85	0	0	2	0	0	50	178	0	0	153	2	116	0	840
Total	0	1149	365	0	5	3	0	0	219	580	1	0	450	2	699	2	3475
*** BREAK ***																	
11:00	0	206	78	0	4	1	0	0	63	227	0	0	97	0	58	0	734
11:15	0	192	70	0	5	1	1	0	80	193	0	0	114	0	60	0	716
11:30	0	216	87	0	2	3	0	0	77	210	0	0	116	0	107	0	818
11:45	0	185	86	0	3	1	1	0	65	197	0	0	114	0	66	0	718
Total	0	799	321	0	14	6	2	0	285	827	0	0	441	0	291	0	2986
12:00	0	215	79	0	11	2	2	0	88	229	0	0	121	0	91	0	838
12:15	0	203	69	0	13	4	4	0	97	277	0	0	120	0	68	0	855
12:30	0	212	99	0	6	3	2	0	73	205	0	0	118	1	74	0	793
12:45	0	202	73	0	10	6	0	0	92	239	0	0	113	0	61	0	796
Total	0	832	320	0	40	15	8	0	350	950	0	0	472	1	294	0	3282
*** BREAK ***																	
15:00	2	246	113	0	9	4	1	0	107	284	0	0	140	0	90	0	996
15:15	0	246	100	0	10	5	1	0	99	299	0	0	152	0	93	0	1005
15:30	0	204	78	0	4	3	1	0	114	315	0	0	214	0	135	0	1068
15:45	0	198	79	0	15	4	1	0	118	355	0	0	228	0	72	0	1070
Total	2	894	370	0	38	16	4	0	438	1253	0	0	734	0	390	0	4139
16:00	0	249	81	0	8	1	2	0	99	344	0	0	167	0	108	0	1059
16:15	0	237	93	0	15	9	0	0	96	369	0	0	164	0	124	0	1107
16:30	0	271	98	0	3	2	0	0	100	358	0	0	216	0	146	0	1194
16:45	0	239	74	0	3	1	1	0	127	385	0	0	201	0	132	0	1163
Total	0	996	346	0	29	13	3	0	422	1456	0	0	748	0	510	0	4523
17:00	0	276	98	0	19	5	1	0	100	345	0	0	185	1	129	0	1159
17:15	0	246	86	0	8	0	0	0	114	413	0	0	220	0	150	0	1237
17:30	0	183	96	0	8	6	0	0	93	375	0	0	219	1	118	0	1099
17:45	0	239	118	0	8	8	4	0	99	347	0	0	183	0	141	0	1147
Total	0	944	398	0	43	19	5	0	406	1480	0	0	807	2	538	0	4642
Grand Total	2	8699	2774	0	230	94	24	0	2524	7392	1	0	4147	5	4063	3	29958
Apprch %	0	75.8	24.2	0	66.1	27	6.9	0	25.5	74.5	0	0	50.5	0.1	49.4	0	
Total %	0	29	9.3	0	0.8	0.3	0.1	0	8.4	24.7	0	0	13.8	0	13.6	0	



MINNESOTA DEPT OF TRANSPORTATION

TRAFFIC DATA COLLECTION - METRO

TH-61 AT CSAH-96 / LAKE DRIVE (WBL)
 REF.PT.: 146.726
 JAMAR # 632 DR
 TURN MOVEMENT COUNT

File Name : TH-61 AT CSAH-96 LAKE DR 2007
 Site Code : 00000000
 Start Date : 9/20/2007
 Page No : 2

Start Time	TH-61 Southbound					LAKE DRIVE Westbound					TH-61 Northbound					CSAH-96 Eastbound					Int. Total
	Left	Thru	Right	Peds	App. Total	Left	Thru	Right	Peds	App. Total	Left	Thru	Right	Peds	App. Total	Left	Thru	Right	Peds	App. Total	
Peak Hour Analysis From 06:00 to 08:45 - Peak 1 of 1																					
Peak Hour for Entire Intersection Begins at 07:00																					
07:00	0	482	101	0	583	20	8	0	0	28	42	139	0	0	181	80	0	203	0	283	1075
07:15	0	576	59	0	635	9	0	0	0	9	58	125	0	0	183	62	0	276	0	338	1165
07:30	0	457	114	0	571	0	0	2	0	2	89	136	0	0	225	84	0	209	1	294	1092
07:45	0	365	100	0	465	4	0	0	0	4	67	135	0	0	202	96	0	216	0	312	983
Total Volume	0	1880	374	0	2254	33	8	2	0	43	256	535	0	0	791	322	0	904	1	1227	4315
% App. Total	0	83.4	16.6	0		76.7	18.6	4.7	0		32.4	67.6	0	0		26.2	0	73.7	0.1		
PHF	.000	.816	.820	.000	.887	.413	.250	.250	.000	.384	.719	.962	.000	.000	.879	.839	.000	.819	.250	.908	.926

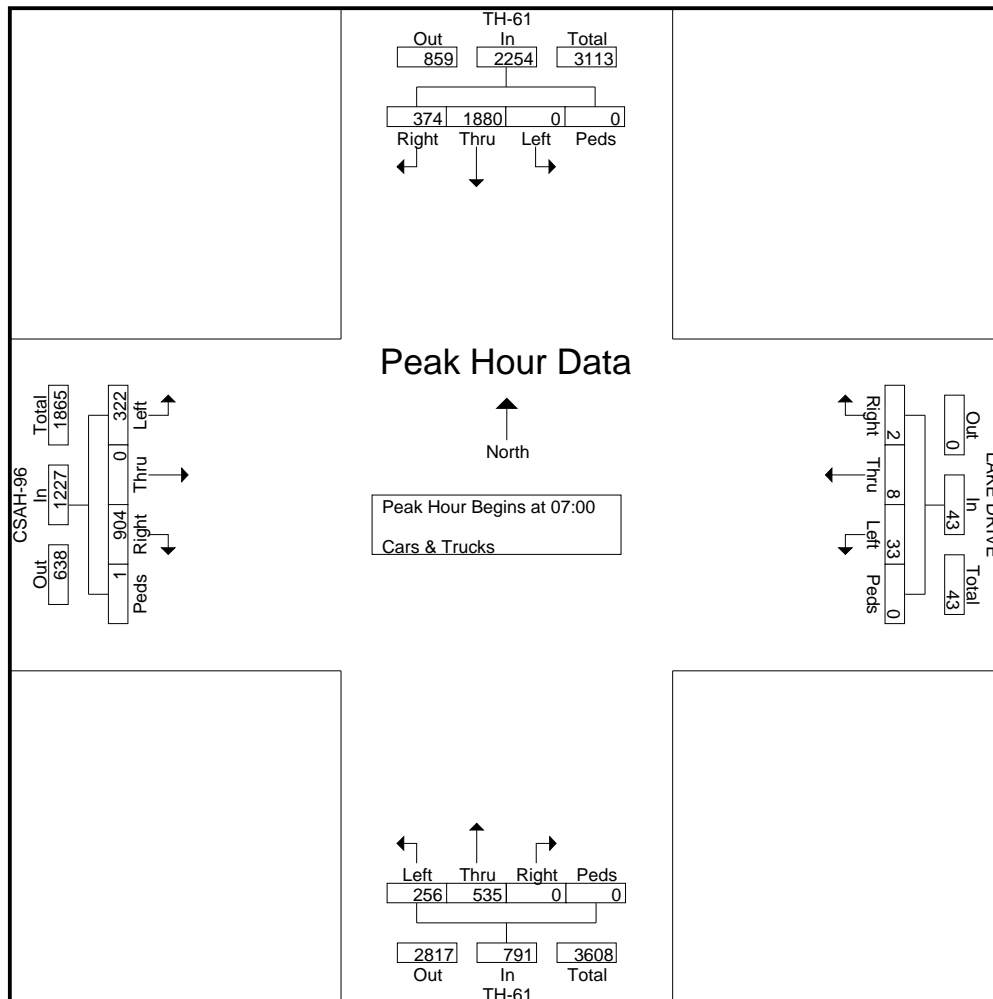



MINNESOTA DEPT OF TRANSPORTATION

TRAFFIC DATA COLLECTION - METRO

TH-61 AT CSAH-96 / LAKE DRIVE (WBL)
 REF.PT.: 146.726
 JAMAR # 632 DR
 TURN MOVEMENT COUNT

File Name : TH-61 AT CSAH-96 LAKE DR 2007
 Site Code : 00000000
 Start Date : 9/20/2007
 Page No : 3

Start Time	TH-61 Southbound					LAKE DRIVE Westbound					TH-61 Northbound					CSAH-96 Eastbound					Int. Total
	Left	Thru	Right	Peds	App. Total	Left	Thru	Right	Peds	App. Total	Left	Thru	Right	Peds	App. Total	Left	Thru	Right	Peds	App. Total	
Peak Hour Analysis From 15:00 to 17:45 - Peak 1 of 1																					
Peak Hour for Entire Intersection Begins at 16:30																					
16:30	0	271	98	0	369	3	2	0	0	5	100	358	0	0	458	216	0	146	0	362	1194
16:45	0	239	74	0	313	3	1	1	0	5	127	385	0	0	512	201	0	132	0	333	1163
17:00	0	276	98	0	374	19	5	1	0	25	100	345	0	0	445	185	1	129	0	315	1159
17:15	0	246	86	0	332	8	0	0	0	8	114	413	0	0	527	220	0	150	0	370	1237
Total Volume	0	1032	356	0	1388	33	8	2	0	43	441	1501	0	0	1942	822	1	557	0	1380	4753
% App. Total	0	74.4	25.6	0		76.7	18.6	4.7	0		22.7	77.3	0	0		59.6	0.1	40.4	0		
PHF	.000	.935	.908	.000	.928	.434	.400	.500	.000	.430	.868	.909	.000	.000	.921	.934	.250	.928	.000	.932	.961

