



# MINNESOTA DEPT OF TRANSPORTATION

## TRAFFIC DATA COLLECTION - METRO

TH-61 AT WHITE BEAR AVE.  
 REF.PT.: 146.268  
 JAMAR # 631 RE  
 TURN MOVEMENT COUNT

File Name : TH-61 AT WHITE BEAR AVE 2007  
 Site Code : 00000000  
 Start Date : 7/18/2007  
 Page No : 1

**Groups Printed- Cars & Trucks**

Start Time	TH-61 Southbound				WHITE BEAR AVE. Westbound				TH-61 Northbound				WHITE BEAR AVE. Eastbound				Int. Total
	Left	Thru	Right	Peds	Left	Thru	Right	Peds	Left	Thru	Right	Peds	Left	Thru	Right	Peds	
06:00	29	255	2	0	2	0	22	0	0	30	1	0	1	0	0	0	342
06:15	36	343	3	0	4	1	29	0	0	28	1	0	0	1	1	0	447
06:30	43	414	4	0	9	2	47	0	0	56	2	0	1	2	1	0	581
06:45	48	446	3	0	5	7	62	0	2	65	3	0	2	1	0	0	644
Total	156	1458	12	0	20	10	160	0	2	179	7	0	4	4	2	0	2014
07:00	57	421	3	0	8	1	50	0	0	49	0	0	2	4	0	3	598
07:15	71	391	2	0	9	1	48	0	0	72	2	0	4	6	0	0	606
07:30	89	375	4	0	9	0	82	1	2	77	2	0	0	3	0	0	644
07:45	93	348	9	0	7	5	93	0	0	104	2	0	9	1	0	0	671
Total	310	1535	18	0	33	7	273	1	2	302	6	0	15	14	0	3	2519
08:00	52	321	7	0	9	3	80	0	0	88	1	0	5	3	1	0	570
08:15	61	286	5	0	6	2	67	0	0	120	4	0	1	3	1	0	556
08:30	54	219	8	0	15	1	91	0	1	94	5	0	3	0	1	0	492
08:45	75	230	3	0	7	1	91	0	0	151	4	0	7	7	1	0	577
Total	242	1056	23	0	37	7	329	0	1	453	14	0	16	13	4	0	2195
*** BREAK ***																	
14:45	61	183	5	0	11	7	101	0	2	179	10	0	3	5	0	1	568
Total	61	183	5	0	11	7	101	0	2	179	10	0	3	5	0	1	568
15:00	76	200	7	0	15	1	104	0	1	215	12	0	7	2	1	0	641
15:15	53	183	6	0	13	4	88	0	1	211	8	0	7	3	0	0	577
15:30	94	199	4	2	16	3	127	2	0	203	15	0	7	5	0	1	678
15:45	87	194	13	1	9	4	113	0	0	249	14	0	4	3	0	0	691
Total	310	776	30	3	53	12	432	2	2	878	49	0	25	13	1	1	2587
16:00	86	185	5	0	10	6	110	9	0	226	5	0	6	3	0	0	651
16:15	90	190	6	0	10	6	114	1	1	264	15	0	3	1	1	0	702
16:30	116	198	7	0	11	7	118	0	2	313	12	0	9	4	1	0	798
16:45	68	167	8	0	12	10	136	0	0	299	6	0	8	7	0	3	724
Total	360	740	26	0	43	29	478	10	3	1102	38	0	26	15	2	3	2875
17:00	114	215	7	0	17	7	119	0	1	267	14	0	9	4	0	1	775
17:15	96	222	4	0	14	9	104	5	2	276	9	3	9	4	3	3	763
17:30	95	200	1	0	13	4	141	1	3	264	12	0	6	3	1	0	744
17:45	90	194	4	0	10	4	105	0	0	241	12	0	4	3	1	0	668
Total	395	831	16	0	54	24	469	6	6	1048	47	3	28	14	5	4	2950
Grand Total	1834	6579	130	3	251	96	2242	19	18	4141	171	3	117	78	14	12	15708
Apprch %	21.5	77	1.5	0	9.6	3.7	86	0.7	0.4	95.6	3.9	0.1	52.9	35.3	6.3	5.4	
Total %	11.7	41.9	0.8	0	1.6	0.6	14.3	0.1	0.1	26.4	1.1	0	0.7	0.5	0.1	0.1	



# MINNESOTA DEPT OF TRANSPORTATION

## TRAFFIC DATA COLLECTION - METRO

TH-61 AT WHITE BEAR AVE.  
 REF.PT.: 146.268  
 JAMAR # 631 RE  
 TURN MOVEMENT COUNT

File Name : TH-61 AT WHITE BEAR AVE 2007  
 Site Code : 00000000  
 Start Date : 7/18/2007  
 Page No : 2

Start Time	TH-61 Southbound					WHITE BEAR AVE. Westbound					TH-61 Northbound					WHITE BEAR AVE. Eastbound					Int. Total
	Left	Thru	Right	Peds	App. Total	Left	Thru	Right	Peds	App. Total	Left	Thru	Right	Peds	App. Total	Left	Thru	Right	Peds	App. Total	
Peak Hour Analysis From 06:00 to 08:45 - Peak 1 of 1																					
Peak Hour for Entire Intersection Begins at 07:00																					
07:00	57	421	3	0	481	8	1	50	0	59	0	49	0	0	49	2	4	0	3	9	598
07:15	71	391	2	0	464	9	1	48	0	58	0	72	2	0	74	4	6	0	0	10	606
07:30	89	375	4	0	468	9	0	82	1	92	2	77	2	0	81	0	3	0	0	3	644
07:45	93	348	9	0	450	7	5	93	0	105	0	104	2	0	106	9	1	0	0	10	671
Total Volume	310	1535	18	0	1863	33	7	273	1	314	2	302	6	0	310	15	14	0	3	32	2519
% App. Total	16.6	82.4	1	0		10.5	2.2	86.9	0.3		0.6	97.4	1.9	0		46.9	43.8	0	9.4		
PHF	.833	.912	.500	.000	.968	.917	.350	.734	.250	.748	.250	.726	.750	.000	.731	.417	.583	.000	.250	.800	.939

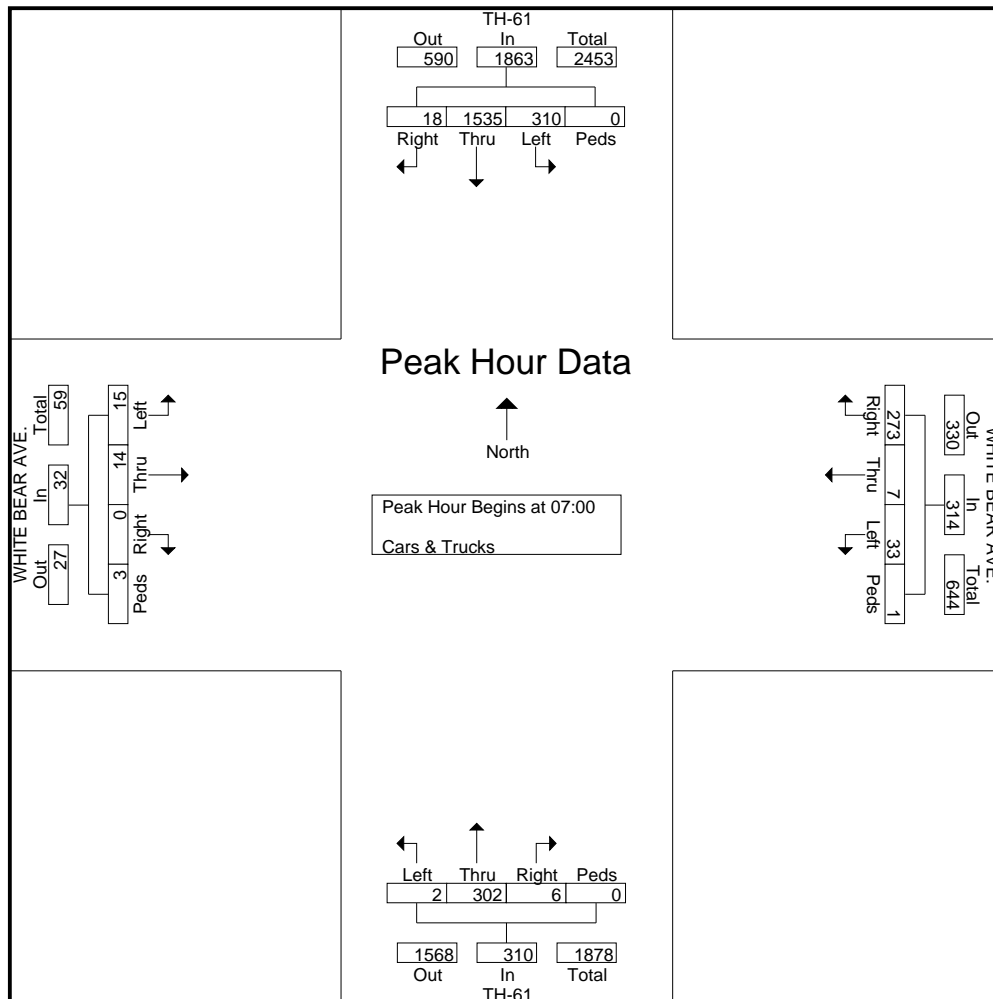



# MINNESOTA DEPT OF TRANSPORTATION

TRAFFIC DATA COLLECTION - METRO

TH-61 AT WHITE BEAR AVE.  
 REF.PT.: 146.268  
 JAMAR # 631 RE  
 TURN MOVEMENT COUNT

File Name : TH-61 AT WHITE BEAR AVE 2007  
 Site Code : 00000000  
 Start Date : 7/18/2007  
 Page No : 3

Start Time	TH-61 Southbound					WHITE BEAR AVE. Westbound					TH-61 Northbound					WHITE BEAR AVE. Eastbound					Int. Total
	Left	Thru	Right	Peds	App. Total	Left	Thru	Right	Peds	App. Total	Left	Thru	Right	Peds	App. Total	Left	Thru	Right	Peds	App. Total	
Peak Hour Analysis From 15:00 to 17:45 - Peak 1 of 1																					
Peak Hour for Entire Intersection Begins at 16:30																					
16:30	116	198	7	0	321	11	7	118	0	136	2	313	12	0	327	9	4	1	0	14	798
16:45	68	167	8	0	243	12	10	136	0	158	0	299	6	0	305	8	7	0	3	18	724
17:00	114	215	7	0	336	17	7	119	0	143	1	267	14	0	282	9	4	0	1	14	775
17:15	96	222	4	0	322	14	9	104	5	132	2	276	9	3	290	9	4	3	3	19	763
Total Volume	394	802	26	0	1222	54	33	477	5	569	5	1155	41	3	1204	35	19	4	7	65	3060
% App. Total	32.2	65.6	2.1	0		9.5	5.8	83.8	0.9		0.4	95.9	3.4	0.2		53.8	29.2	6.2	10.8		
PHF	.849	.903	.813	.000	.909	.794	.825	.877	.250	.900	.625	.923	.732	.250	.920	.972	.679	.333	.583	.855	.959

