



MINNESOTA DEPT OF TRANSPORTATION

TRAFFIC DATA COLLECTION - METRO

TH-61 at Cedar Ave. (WBL)
 ref.pt.: 145.157
 Data by : Alliant Inc
 TURN MOVEMENT COUNT

File Name : TH-61 at Cedar Ave WBL 2008
 Site Code : 00000111
 Start Date : 9/25/2008
 Page No : 1

Groups Printed- Unshifted

Start Time	TH-61 Southbound				Cedar Ave Westbound				TH-61 Northbound				Cedar Ave Eastbound				Int. Total
	Left	Thru	Right	Peds	Left	Thru	Right	Peds	Left	Thru	Right	Peds	Left	Thru	Right	Peds	
06:00	1	133	0	0	12	2	6	0	2	20	0	0	1	0	9	0	186
06:15	1	185	0	0	13	6	4	0	12	49	2	0	0	2	16	0	290
06:30	7	263	0	0	18	6	4	0	12	36	7	0	0	5	39	0	397
06:45	6	294	0	0	13	10	3	0	14	86	3	0	0	11	49	0	489
Total	15	875	0	0	56	24	17	0	40	191	12	0	1	18	113	0	1362
07:00	15	349	0	1	26	10	10	0	6	99	6	0	0	28	50	0	600
07:15	12	367	0	0	29	12	2	0	7	90	5	0	1	39	58	0	622
07:30	13	365	0	0	14	16	5	0	14	98	7	0	0	16	51	0	599
07:45	8	338	0	0	17	13	3	0	13	109	10	0	0	15	39	0	565
Total	48	1419	0	1	86	51	20	0	40	396	28	0	1	98	198	0	2386
08:00	9	224	1	0	16	7	13	0	10	124	5	0	0	10	25	1	445
08:15	6	179	0	0	13	2	3	0	4	103	5	0	1	9	33	0	358
08:30	9	204	0	0	15	12	6	0	6	104	7	0	0	12	19	0	394
08:45	11	165	0	0	15	12	13	1	3	110	26	0	2	11	15	0	384
Total	35	772	1	0	59	33	35	1	23	441	43	0	3	42	92	1	1581
09:00	8	144	2	0	33	9	10	0	9	97	17	0	0	9	13	0	351
09:15	10	154	0	0	8	5	12	0	5	103	12	0	0	10	18	0	337
*** BREAK ***																	
Total	18	298	2	0	41	14	22	0	14	200	29	0	0	19	31	0	688
*** BREAK ***																	
10:30	9	138	0	0	5	3	4	0	3	112	7	0	2	9	22	0	314
10:45	15	146	1	0	10	3	10	0	3	119	14	0	0	13	12	0	346
Total	24	284	1	0	15	6	14	0	6	231	21	0	2	22	34	0	660
11:00	16	145	0	0	10	3	8	0	10	115	23	0	0	5	16	0	351
11:15	5	175	3	0	31	1	7	0	2	136	13	0	1	3	27	0	404
11:30	15	152	0	0	27	4	7	0	4	171	7	0	0	6	31	0	424
11:45	11	169	2	0	8	4	4	0	14	182	12	0	1	11	12	0	430
Total	47	641	5	0	76	12	26	0	30	604	55	0	2	25	86	0	1609
12:00	9	151	2	0	10	2	6	0	7	176	16	0	0	10	20	0	409
12:15	13	161	0	0	21	6	5	0	9	195	13	0	0	4	17	0	444
12:30	12	175	0	0	18	8	8	0	7	134	13	0	0	7	20	0	402
12:45	9	180	2	0	8	7	3	0	3	171	7	0	0	4	20	0	414
Total	43	667	4	0	57	23	22	0	26	676	49	0	0	25	77	0	1669
13:00	16	153	0	0	8	4	12	0	10	128	13	0	0	8	10	0	362
13:15	12	148	1	0	15	6	9	0	9	152	12	0	0	4	12	0	380
*** BREAK ***																	
Total	28	301	1	0	23	10	21	0	19	280	25	0	0	12	22	0	742
*** BREAK ***																	
14:30	11	158	1	0	8	6	10	0	13	162	16	0	1	8	26	0	420
14:45	11	136	0	0	10	25	14	0	7	192	22	0	0	13	29	3	462
Total	22	294	1	0	18	31	24	0	20	354	38	0	1	21	55	3	882
15:00	11	148	2	0	6	11	13	0	18	211	24	0	0	16	44	0	504
15:15	13	196	1	0	17	16	24	0	15	211	26	0	0	15	22	0	556
15:30	16	189	1	0	7	11	5	0	8	238	17	0	1	14	39	0	546
15:45	12	163	1	0	15	9	14	0	15	234	30	1	0	14	21	0	529
Total	52	696	5	0	45	47	56	0	56	894	97	1	1	59	126	0	2135



MINNESOTA DEPT OF TRANSPORTATION

TRAFFIC DATA COLLECTION - METRO

TH-61 at Cedar Ave. (WBL)
 ref.pt.: 145.157
 Data by : Alliant Inc
 TURN MOVEMENT COUNT

File Name : TH-61 at Cedar Ave WBL 2008
 Site Code : 00000111
 Start Date : 9/25/2008
 Page No : 2

Groups Printed- Unshifted

Start Time	TH-61 Southbound				Cedar Ave Westbound				TH-61 Northbound				Cedar Ave Eastbound				Int. Total
	Left	Thru	Right	Peds	Left	Thru	Right	Peds	Left	Thru	Right	Peds	Left	Thru	Right	Peds	
16:00	22	193	0	0	12	6	10	0	10	252	30	0	1	14	18	0	568
16:15	16	201	0	0	8	12	19	0	16	287	21	0	0	25	26	0	631
16:30	17	190	1	0	2	16	20	0	16	267	18	0	1	16	30	0	594
16:45	29	172	0	0	7	16	14	0	19	358	22	0	0	17	16	0	670
Total	84	756	1	0	29	50	63	0	61	1164	91	0	2	72	90	0	2463
17:00	25	214	0	0	16	11	26	0	14	322	21	0	0	19	39	0	707
17:15	28	176	2	0	18	17	16	0	19	316	18	0	1	10	23	0	644
17:30	28	182	0	0	12	19	16	0	7	238	32	1	2	13	29	0	579
17:45	25	171	1	0	11	13	22	0	17	238	20	0	0	14	20	0	552
Total	106	743	3	0	57	60	80	0	57	1114	91	1	3	56	111	0	2482
Grand Total	522	7746	24	1	562	361	400	1	392	6545	579	2	16	469	1035	4	18659
Apprch %	6.3	93.4	0.3	0	42.4	27.3	30.2	0.1	5.2	87.1	7.7	0	1	30.8	67.9	0.3	
Total %	2.8	41.5	0.1	0	3	1.9	2.1	0	2.1	35.1	3.1	0	0.1	2.5	5.5	0	



MINNESOTA DEPT OF TRANSPORTATION

TRAFFIC DATA COLLECTION - METRO

TH-61 at Cedar Ave. (WBL)
 ref.pt.: 145.157
 Data by : Alliant Inc
 TURN MOVEMENT COUNT

File Name : TH-61 at Cedar Ave WBL 2008
 Site Code : 00000111
 Start Date : 9/25/2008
 Page No : 3

Start Time	TH-61 Southbound					Cedar Ave Westbound					TH-61 Northbound					Cedar Ave Eastbound					Int. Total
	Left	Thru	Right	Peds	App. Total	Left	Thru	Right	Peds	App. Total	Left	Thru	Right	Peds	App. Total	Left	Thru	Right	Peds	App. Total	
Peak Hour Analysis From 06:00 to 11:45 - Peak 1 of 1																					
Peak Hour for Entire Intersection Begins at 07:00																					
07:00	15	349	0	1	365	26	10	10	0	46	6	99	6	0	111	0	28	50	0	78	600
07:15	12	367	0	0	379	29	12	2	0	43	7	90	5	0	102	1	39	58	0	98	622
07:30	13	365	0	0	378	14	16	5	0	35	14	98	7	0	119	0	16	51	0	67	599
07:45	8	338	0	0	346	17	13	3	0	33	13	109	10	0	132	0	15	39	0	54	565
Total Volume	48	1419	0	1	1468	86	51	20	0	157	40	396	28	0	464	1	98	198	0	297	2386
% App. Total	3.3	96.7	0	0.1		54.8	32.5	12.7	0		8.6	85.3	6	0		0.3	33	66.7	0		
PHF	.800	.967	.000	.250	.968	.741	.797	.500	.000	.853	.714	.908	.700	.000	.879	.250	.628	.853	.000	.758	.959

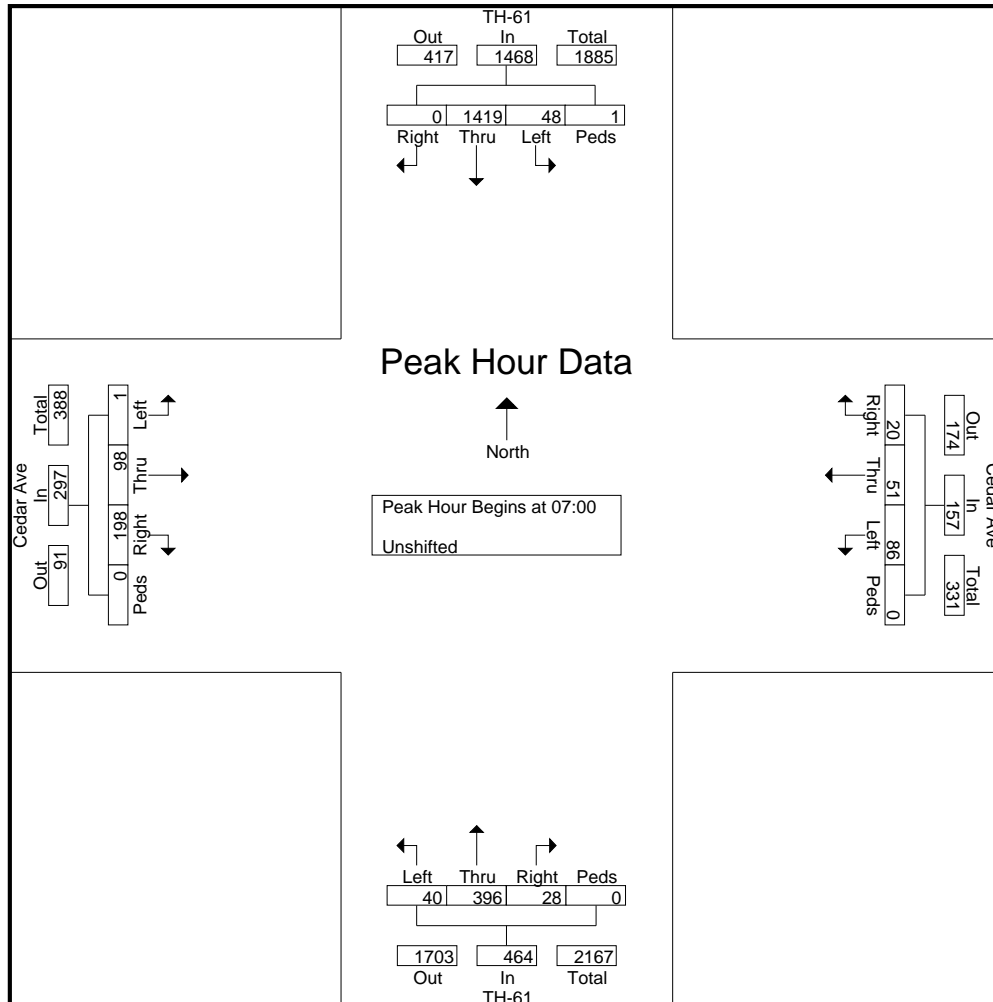



MINNESOTA DEPT OF TRANSPORTATION

TRAFFIC DATA COLLECTION - METRO

TH-61 at Cedar Ave. (WBL)
 ref.pt.: 145.157
 Data by : Alliant Inc
 TURN MOVEMENT COUNT

File Name : TH-61 at Cedar Ave WBL 2008
 Site Code : 00000111
 Start Date : 9/25/2008
 Page No : 4

Start Time	TH-61 Southbound					Cedar Ave Westbound					TH-61 Northbound					Cedar Ave Eastbound					Int. Total
	Left	Thru	Right	Peds	App. Total	Left	Thru	Right	Peds	App. Total	Left	Thru	Right	Peds	App. Total	Left	Thru	Right	Peds	App. Total	
16:30	17	190	1	0	208	2	16	20	0	38	16	267	18	0	301	1	16	30	0	47	594
16:45	29	172	0	0	201	7	16	14	0	37	19	358	22	0	399	0	17	16	0	33	670
17:00	25	214	0	0	239	16	11	26	0	53	14	322	21	0	357	0	19	39	0	58	707
17:15	28	176	2	0	206	18	17	16	0	51	19	316	18	0	353	1	10	23	0	34	644
Total Volume	99	752	3	0	854	43	60	76	0	179	68	1263	79	0	1410	2	62	108	0	172	2615
% App. Total	11.6	88.1	0.4	0		24	33.5	42.5	0		4.8	89.6	5.6	0		1.2	36	62.8	0		
PHF	.853	.879	.375	.000	.893	.597	.882	.731	.000	.844	.895	.882	.898	.000	.883	.500	.816	.692	.000	.741	.925

Peak Hour Analysis From 12:00 to 17:45 - Peak 1 of 1

Peak Hour for Entire Intersection Begins at 16:30

