



MINNESOTA DEPT OF TRANSPORTATION

TRAFFIC DATA COLLECTION - METRO

TH-61 at Co.Rd. D (Maplewood)

Ref.Pt.: 143.xxx

Data by: Alliant Inc.

TURN MOVEMENT COUNT

File Name : TH-61 at Co Rd D 2008

Site Code : 00000105

Start Date : 9/16/2008

Page No : 1

Groups Printed- Unshifted

Start Time	TH-61 Southbound				Co.Rd. D Westbound				TH-61 Northbound				Co.Rd. D Eastbound				Int. Total
	Left	Thru	Right	Peds	Left	Thru	Right	Peds	Left	Thru	Right	Peds	Left	Thru	Right	Peds	
06:00	12	104	4	0	3	3	3	0	4	65	2	1	7	4	4	0	216
06:15	22	127	10	0	6	4	6	0	2	77	0	0	15	5	5	0	279
06:30	20	263	7	0	10	2	17	0	8	100	2	0	9	7	11	0	456
06:45	35	340	22	0	11	10	11	0	15	116	5	0	18	10	20	0	613
Total	89	834	43	0	30	19	37	0	29	358	9	1	49	26	40	0	1564
07:00	25	393	20	0	13	16	16	0	14	113	1	0	21	6	22	0	660
07:15	29	370	15	0	20	12	30	1	6	131	2	1	30	14	18	0	679
07:30	20	365	67	0	24	20	24	0	18	152	10	0	24	8	32	0	764
07:45	36	457	34	0	28	15	16	0	13	139	8	1	22	18	26	0	813
Total	110	1585	136	0	85	63	86	1	51	535	21	2	97	46	98	0	2916
08:00	33	371	28	0	20	11	14	0	18	117	4	1	17	16	16	0	666
08:15	22	303	26	0	13	14	23	0	17	116	5	0	28	15	20	0	602
08:30	30	265	26	0	12	10	15	0	9	126	6	0	15	14	24	0	552
08:45	33	195	11	0	9	11	16	0	14	144	11	0	24	21	25	0	514
Total	118	1134	91	0	54	46	68	0	58	503	26	1	84	66	85	0	2334
09:00	40	222	22	0	10	14	23	0	19	156	7	1	21	25	23	0	583
09:15	34	181	8	0	6	13	10	0	9	119	5	0	28	12	24	0	449
*** BREAK ***																	
Total	74	403	30	0	16	27	33	0	28	275	12	1	49	37	47	0	1032
*** BREAK ***																	
10:30	57	162	16	0	2	13	26	0	12	155	6	0	19	16	10	0	494
10:45	49	179	12	0	9	13	22	0	18	156	7	2	13	22	19	0	521
Total	106	341	28	0	11	26	48	0	30	311	13	2	32	38	29	0	1015
11:00	54	187	13	0	10	13	27	0	22	182	13	0	28	20	14	0	583
11:15	37	158	18	0	9	12	36	0	19	157	8	0	24	16	14	0	508
11:30	43	166	25	0	17	27	33	0	23	198	10	0	24	23	13	0	602
11:45	65	157	15	0	18	23	30	0	22	175	16	0	23	27	14	0	585
Total	199	668	71	0	54	75	126	0	86	712	47	0	99	86	55	0	2278
12:00	62	209	21	0	5	21	40	0	30	196	16	1	23	20	18	0	662
12:15	33	158	25	0	14	30	43	0	17	186	14	1	17	35	27	0	600
12:30	44	186	28	0	19	17	35	0	22	187	11	0	19	18	11	0	597
12:45	57	159	18	0	31	24	46	0	26	186	8	0	28	27	27	0	637
Total	196	712	92	0	69	92	164	0	95	755	49	2	87	100	83	0	2496
13:00	50	159	15	0	11	16	40	0	19	203	10	0	27	22	17	0	589
13:15	47	173	23	0	9	26	36	0	10	174	14	0	25	20	18	0	575
*** BREAK ***																	
Total	97	332	38	0	20	42	76	0	29	377	24	0	52	42	35	0	1164
*** BREAK ***																	
14:30	56	217	30	0	14	29	43	0	26	253	11	0	19	14	13	0	725
14:45	52	177	18	0	10	21	43	0	21	292	7	0	30	26	19	0	716
Total	108	394	48	0	24	50	86	0	47	545	18	0	49	40	32	0	1441
15:00	41	218	19	0	10	16	46	0	20	257	12	0	52	32	33	1	757
15:15	55	192	18	0	17	32	54	0	20	288	14	1	34	18	20	0	763
15:30	48	213	20	0	12	28	54	1	19	283	11	1	29	23	24	0	766
15:45	35	244	32	0	10	27	61	0	25	351	20	0	29	25	15	0	874
Total	179	867	89	0	49	103	215	1	84	1179	57	2	144	98	92	1	3160



MINNESOTA DEPT OF TRANSPORTATION

TRAFFIC DATA COLLECTION - METRO

TH-61 at Co.Rd. D (Maplewood)

Ref.Pt.: 143.xxx

Data by: Alliant Inc.

TURN MOVEMENT COUNT

File Name : TH-61 at Co Rd D 2008

Site Code : 00000105

Start Date : 9/16/2008

Page No : 2

Groups Printed- Unshifted

Start Time	TH-61 Southbound				Co.Rd. D Westbound				TH-61 Northbound				Co.Rd. D Eastbound				Int. Total
	Left	Thru	Right	Peds	Left	Thru	Right	Peds	Left	Thru	Right	Peds	Left	Thru	Right	Peds	
16:00	28	209	24	0	10	22	63	0	33	360	18	0	36	30	19	0	852
16:15	47	224	27	0	7	17	44	0	34	355	27	0	31	26	24	0	863
16:30	37	219	11	0	17	29	69	0	20	401	29	1	36	28	39	0	936
16:45	49	200	22	0	14	26	54	1	40	392	17	2	29	26	27	0	899
Total	161	852	84	0	48	94	230	1	127	1508	91	3	132	110	109	0	3550
17:00	49	207	21	0	8	31	49	0	40	450	23	4	31	27	26	0	966
17:15	61	196	22	0	14	25	46	0	36	424	22	0	36	35	29	0	946
17:30	70	210	23	0	9	18	44	0	23	378	27	2	37	39	35	0	915
17:45	44	176	17	0	11	31	35	0	28	339	27	3	25	32	27	0	795
Total	224	789	83	0	42	105	174	0	127	1591	99	9	129	133	117	0	3622
Grand Total	1661	8911	833	0	502	742	1343	3	791	8649	466	23	1003	822	822	1	26572
Apprch %	14.6	78.1	7.3	0	19.4	28.6	51.9	0.1	8	87.1	4.7	0.2	37.9	31	31	0	
Total %	6.3	33.5	3.1	0	1.9	2.8	5.1	0	3	32.5	1.8	0.1	3.8	3.1	3.1	0	



MINNESOTA DEPT OF TRANSPORTATION

TRAFFIC DATA COLLECTION - METRO

TH-61 at Co.Rd. D (Maplewood)
 Ref.Pt.: 143.xxx
 Data by: Alliant Inc.
 TURN MOVEMENT COUNT

File Name : TH-61 at Co Rd D 2008
 Site Code : 00000105
 Start Date : 9/16/2008
 Page No : 3

Start Time	TH-61 Southbound					Co.Rd. D Westbound					TH-61 Northbound					Co.Rd. D Eastbound					Int. Total
	Left	Thru	Right	Peds	App. Total	Left	Thru	Right	Peds	App. Total	Left	Thru	Right	Peds	App. Total	Left	Thru	Right	Peds	App. Total	
Peak Hour Analysis From 06:00 to 09:15 - Peak 1 of 1																					
Peak Hour for Entire Intersection Begins at 07:15																					
07:15	29	370	15	0	414	20	12	30	1	63	6	131	2	1	140	30	14	18	0	62	679
07:30	20	365	67	0	452	24	20	24	0	68	18	152	10	0	180	24	8	32	0	64	764
07:45	36	457	34	0	527	28	15	16	0	59	13	139	8	1	161	22	18	26	0	66	813
08:00	33	371	28	0	432	20	11	14	0	45	18	117	4	1	140	17	16	16	0	49	666
Total Volume	118	1563	144	0	1825	92	58	84	1	235	55	539	24	3	621	93	56	92	0	241	2922
% App. Total	6.5	85.6	7.9	0		39.1	24.7	35.7	0.4		8.9	86.8	3.9	0.5		38.6	23.2	38.2	0		
PHF	.819	.855	.537	.000	.866	.821	.725	.700	.250	.864	.764	.887	.600	.750	.863	.775	.778	.719	.000	.913	.899

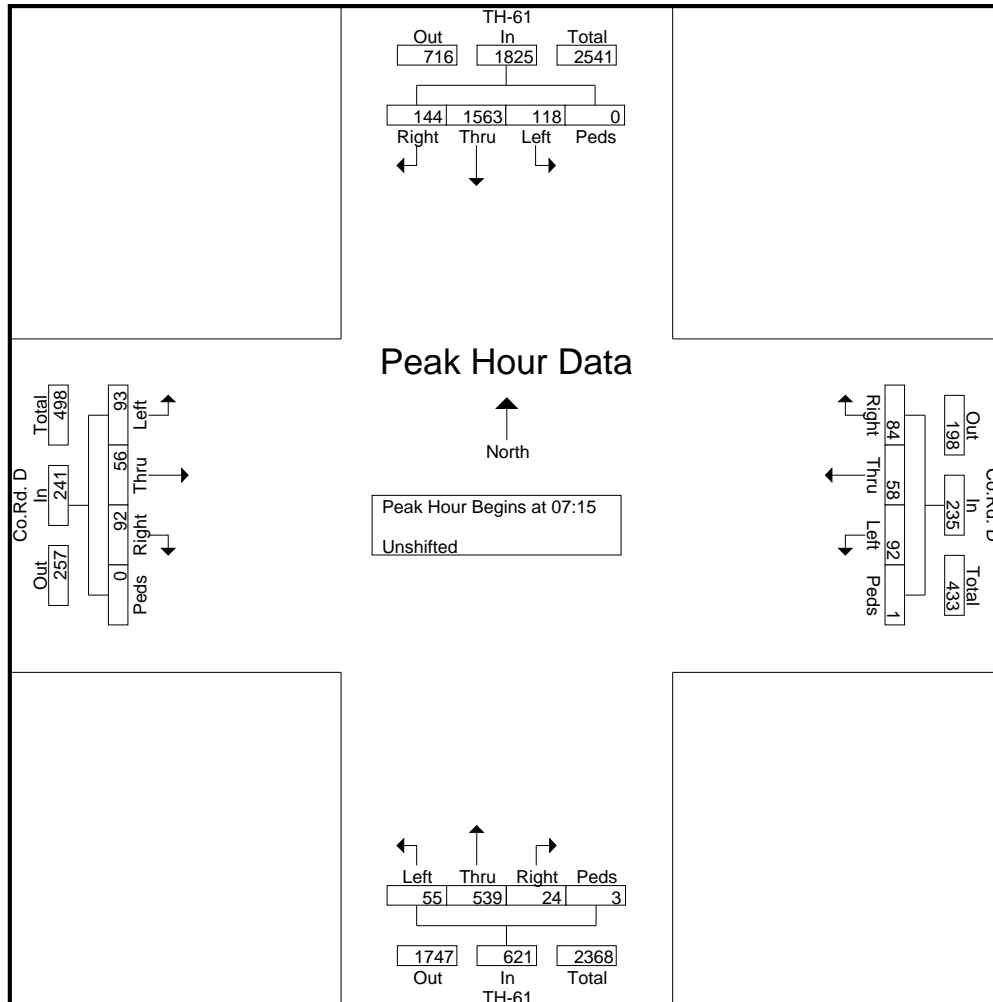



MINNESOTA DEPT OF TRANSPORTATION

TRAFFIC DATA COLLECTION - METRO

TH-61 at Co.Rd. D (Maplewood)
 Ref.Pt.: 143.xxx
 Data by: Alliant Inc.
 TURN MOVEMENT COUNT

File Name : TH-61 at Co Rd D 2008
 Site Code : 00000105
 Start Date : 9/16/2008
 Page No : 4

Start Time	TH-61 Southbound					Co.Rd. D Westbound					TH-61 Northbound					Co.Rd. D Eastbound					Int. Total
	Left	Thru	Right	Peds	App. Total	Left	Thru	Right	Peds	App. Total	Left	Thru	Right	Peds	App. Total	Left	Thru	Right	Peds	App. Total	

Peak Hour Analysis From 14:30 to 17:45 - Peak 1 of 1
 Peak Hour for Entire Intersection Begins at 16:30

16:30	37	219	11	0	267	17	29	69	0	115	20	401	29	1	451	36	28	39	0	103	936
16:45	49	200	22	0	271	14	26	54	1	95	40	392	17	2	451	29	26	27	0	82	899
17:00	49	207	21	0	277	8	31	49	0	88	40	450	23	4	517	31	27	26	0	84	966
17:15	61	196	22	0	279	14	25	46	0	85	36	424	22	0	482	36	35	29	0	100	946
Total Volume	196	822	76	0	1094	53	111	218	1	383	136	1667	91	7	1901	132	116	121	0	369	3747
% App. Total	17.9	75.1	6.9	0		13.8	29	56.9	0.3		7.2	87.7	4.8	0.4		35.8	31.4	32.8	0		
PHF	.803	.938	.864	.000	.980	.779	.895	.790	.250	.833	.850	.926	.784	.438	.919	.917	.829	.776	.000	.896	.970

