



MINNESOTA DEPT OF TRANSPORTATION

TRAFFIC DATA COLLECTION - METRO

TH-61 at Co.Rd. C (Maplewood)

Ref.Pt.: 142.282

Data by: Alliant Inc

TURN MOVEMENT COUNT

File Name : TH-61 at Co Rd C 2008

Site Code : 00002410

Start Date : 9/16/2008

Page No : 1

Groups Printed- Unshifted

Start Time	TH-61 Southbound				Co.Rd. C Westbound				TH-61 Northbound				Co.Rd. C Eastbound				Int. Total
	Left	Thru	Right	Peds	Left	Thru	Right	Peds	Left	Thru	Right	Peds	Left	Thru	Right	Peds	
06:00	1	104	10	0	0	0	0	0	0	0	0	0	5	2	6	0	128
06:15	1	179	16	0	0	0	0	0	0	0	0	0	10	5	9	0	220
06:30	0	268	19	1	28	5	6	0	1	126	4	0	8	3	13	0	482
06:45	5	317	28	0	21	8	5	0	1	174	15	0	8	4	16	0	602
Total	7	868	73	1	49	13	11	0	2	300	19	0	31	14	44	0	1432
07:00	3	393	27	0	38	18	8	0	4	139	9	0	9	5	13	0	666
07:15	2	442	28	1	35	23	3	0	0	165	20	0	12	17	18	0	766
07:30	8	505	19	0	43	24	10	0	3	198	12	0	11	13	20	0	866
07:45	5	399	23	0	27	14	9	0	0	221	24	0	16	7	6	0	751
Total	18	1739	97	1	143	79	30	0	7	723	65	0	48	42	57	0	3049
08:00	7	338	10	0	27	10	8	0	1	179	12	0	15	6	9	0	622
08:15	8	306	5	0	21	6	12	0	1	181	14	1	14	11	6	0	586
08:30	9	234	11	0	23	10	12	0	1	189	10	0	13	10	2	0	524
08:45	6	217	9	0	14	7	6	0	2	207	20	0	11	8	7	0	514
Total	30	1095	35	0	85	33	38	0	5	756	56	1	53	35	24	0	2246
09:00	9	174	6	0	19	6	6	0	3	180	19	0	10	8	4	0	444
09:15	6	160	5	0	21	7	9	0	1	158	23	0	13	7	7	0	417
*** BREAK ***																	
Total	15	334	11	0	40	13	15	0	4	338	42	0	23	15	11	0	861
*** BREAK ***																	
10:30	5	153	8	0	9	7	6	0	2	201	16	0	10	8	7	0	432
10:45	7	177	21	0	11	11	5	0	6	164	16	0	17	10	10	0	455
Total	12	330	29	0	20	18	11	0	8	365	32	0	27	18	17	0	887
11:00	8	199	8	0	6	3	17	0	8	225	26	0	26	4	4	0	534
11:15	12	190	10	2	19	5	8	0	2	183	15	2	11	18	7	0	484
11:30	6	203	17	0	8	14	8	0	5	225	10	0	14	7	14	0	531
11:45	3	207	15	0	16	16	7	0	4	203	15	0	12	9	6	0	513
Total	29	799	50	2	49	38	40	0	19	836	66	2	63	38	31	0	2062
12:00	7	211	24	0	17	9	8	0	7	245	17	0	20	9	4	0	578
12:15	3	195	15	0	11	10	8	0	5	240	9	0	14	7	5	0	522
12:30	8	176	9	0	11	6	13	0	14	231	26	0	19	11	7	0	531
12:45	9	211	20	0	20	19	12	0	7	219	18	0	24	14	2	0	575
Total	27	793	68	0	59	44	41	0	33	935	70	0	77	41	18	0	2206
13:00	4	185	19	0	10	9	10	0	5	227	14	0	16	13	7	0	519
13:15	4	193	11	2	11	5	10	0	2	205	13	2	17	15	3	0	493
*** BREAK ***																	
Total	8	378	30	2	21	14	20	0	7	432	27	2	33	28	10	0	1012
*** BREAK ***																	
14:30	12	197	17	0	20	6	11	1	4	268	15	0	11	13	6	0	581
14:45	13	210	14	0	20	15	8	0	3	215	16	0	24	20	6	0	564
Total	25	407	31	0	40	21	19	1	7	483	31	0	35	33	12	0	1145
15:00	9	283	20	1	14	21	7	0	4	213	20	0	31	16	12	0	651
15:15	6	208	15	0	14	11	9	0	9	214	29	0	26	22	3	0	566
15:30	10	248	27	0	21	12	9	0	5	251	25	0	26	27	2	0	663
15:45	11	245	28	1	19	16	12	1	4	294	28	1	23	29	7	0	719
Total	36	984	90	2	68	60	37	1	22	972	102	1	106	94	24	0	2599



MINNESOTA DEPT OF TRANSPORTATION

TRAFFIC DATA COLLECTION - METRO

TH-61 at Co.Rd. C (Maplewood)

Ref.Pt.: 142.282

Data by: Alliant Inc

TURN MOVEMENT COUNT

File Name : TH-61 at Co Rd C 2008

Site Code : 00002410

Start Date : 9/16/2008

Page No : 2

Groups Printed- Unshifted

Start Time	TH-61 Southbound				Co.Rd. C Westbound				TH-61 Northbound				Co.Rd. C Eastbound				Int. Total
	Left	Thru	Right	Peds	Left	Thru	Right	Peds	Left	Thru	Right	Peds	Left	Thru	Right	Peds	
16:00	7	232	10	0	15	13	8	0	9	276	25	0	42	32	9	0	678
16:15	11	229	19	0	14	8	9	0	9	371	28	0	35	27	8	0	768
16:30	13	264	19	1	30	12	7	0	21	332	38	0	30	37	7	0	811
16:45	11	246	16	0	27	19	13	0	20	420	31	2	39	40	8	0	892
Total	42	971	64	1	86	52	37	0	59	1399	122	2	146	136	32	0	3149
17:00	8	248	20	0	20	21	6	0	22	363	36	0	51	44	8	0	847
17:15	6	234	17	0	22	20	8	0	12	369	37	6	58	43	13	0	845
17:30	11	200	10	0	24	12	6	0	7	374	29	2	59	39	5	0	778
17:45	15	208	9	1	18	18	3	0	11	339	25	0	33	39	10	0	729
Total	40	890	56	1	84	71	23	0	52	1445	127	8	201	165	36	0	3199
Grand Total	289	9588	634	10	744	456	322	2	225	8984	759	16	843	659	316	0	23847
Apprch %	2.7	91.1	6	0.1	48.8	29.9	21.1	0.1	2.3	90	7.6	0.2	46.4	36.2	17.4	0	
Total %	1.2	40.2	2.7	0	3.1	1.9	1.4	0	0.9	37.7	3.2	0.1	3.5	2.8	1.3	0	



MINNESOTA DEPT OF TRANSPORTATION

TRAFFIC DATA COLLECTION - METRO

TH-61 at Co.Rd. C (Maplewood)
 Ref.Pt.: 142.282
 Data by: Alliant Inc
 TURN MOVEMENT COUNT

File Name : TH-61 at Co Rd C 2008
 Site Code : 00002410
 Start Date : 9/16/2008
 Page No : 3

Start Time	TH-61 Southbound					Co.Rd. C Westbound					TH-61 Northbound					Co.Rd. C Eastbound					Int. Total
	Left	Thru	Right	Peds	App. Total	Left	Thru	Right	Peds	App. Total	Left	Thru	Right	Peds	App. Total	Left	Thru	Right	Peds	App. Total	
Peak Hour Analysis From 06:00 to 09:15 - Peak 1 of 1																					
Peak Hour for Entire Intersection Begins at 07:00																					
07:00	3	393	27	0	423	38	18	8	0	64	4	139	9	0	152	9	5	13	0	27	666
07:15	2	442	28	1	473	35	23	3	0	61	0	165	20	0	185	12	17	18	0	47	766
07:30	8	505	19	0	532	43	24	10	0	77	3	198	12	0	213	11	13	20	0	44	866
07:45	5	399	23	0	427	27	14	9	0	50	0	221	24	0	245	16	7	6	0	29	751
Total Volume	18	1739	97	1	1855	143	79	30	0	252	7	723	65	0	795	48	42	57	0	147	3049
% App. Total	1	93.7	5.2	0.1		56.7	31.3	11.9	0		0.9	90.9	8.2	0		32.7	28.6	38.8	0		
PHF	.563	.861	.866	.250	.872	.831	.823	.750	.000	.818	.438	.818	.677	.000	.811	.750	.618	.713	.000	.782	.880

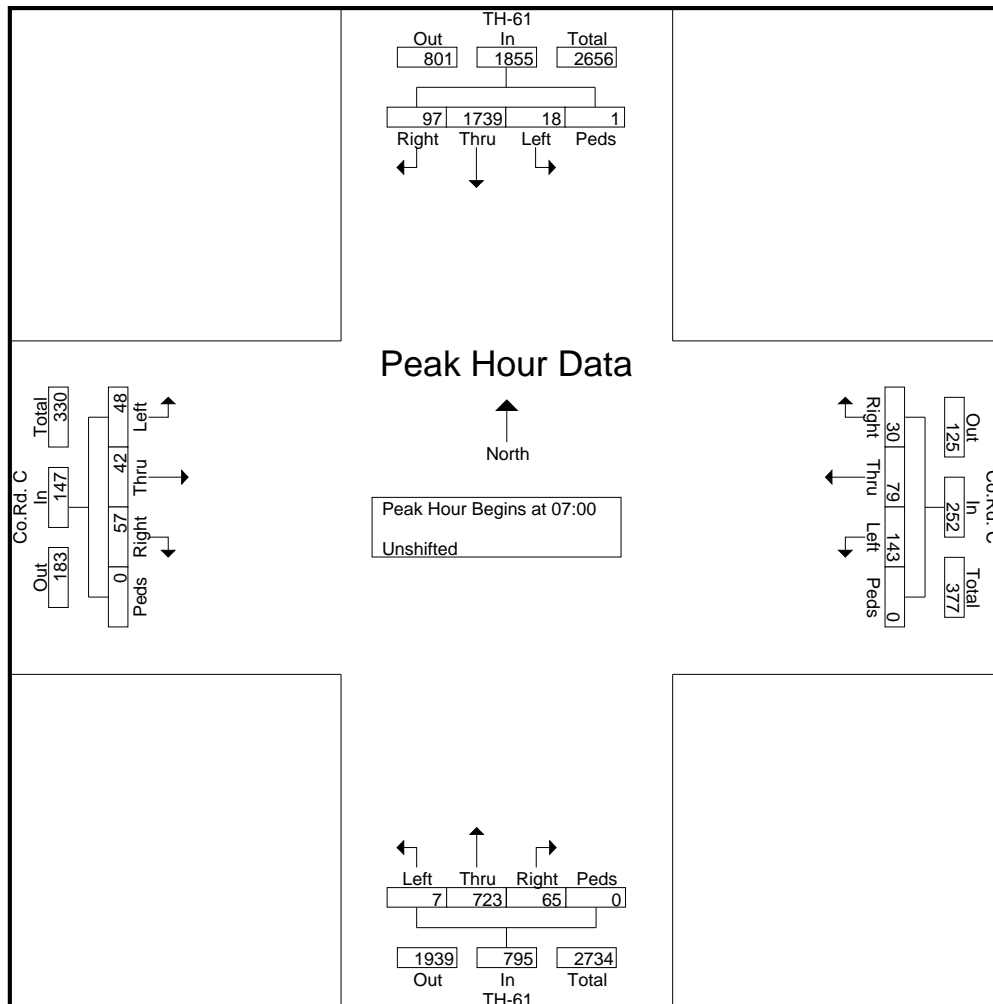



MINNESOTA DEPT OF TRANSPORTATION

TRAFFIC DATA COLLECTION - METRO

TH-61 at Co.Rd. C (Maplewood)
 Ref.Pt.: 142.282
 Data by: Alliant Inc
 TURN MOVEMENT COUNT

File Name : TH-61 at Co Rd C 2008
 Site Code : 00002410
 Start Date : 9/16/2008
 Page No : 4

Start Time	TH-61 Southbound					Co.Rd. C Westbound					TH-61 Northbound					Co.Rd. C Eastbound					Int. Total
	Left	Thru	Right	Peds	App. Total	Left	Thru	Right	Peds	App. Total	Left	Thru	Right	Peds	App. Total	Left	Thru	Right	Peds	App. Total	
16:30	13	264	19	1	297	30	12	7	0	49	21	332	38	0	391	30	37	7	0	74	811
16:45	11	246	16	0	273	27	19	13	0	59	20	420	31	2	473	39	40	8	0	87	892
17:00	8	248	20	0	276	20	21	6	0	47	22	363	36	0	421	51	44	8	0	103	847
17:15	6	234	17	0	257	22	20	8	0	50	12	369	37	6	424	58	43	13	0	114	845
Total Volume	38	992	72	1	1103	99	72	34	0	205	75	1484	142	8	1709	178	164	36	0	378	3395
% App. Total	3.4	89.9	6.5	0.1		48.3	35.1	16.6	0		4.4	86.8	8.3	0.5		47.1	43.4	9.5	0		
PHF	.731	.939	.900	.250	.928	.825	.857	.654	.000	.869	.852	.883	.934	.333	.903	.767	.932	.692	.000	.829	.952

Peak Hour Analysis From 14:30 to 17:45 - Peak 1 of 1

Peak Hour for Entire Intersection Begins at 16:30

