



MINNESOTA DEPT OF TRANSPORTATION

TRAFFIC DATA COLLECTION - METRO

TH-61 at Roselawn Ave. (Maplewood)

Ref.Pt.: 140.566

Data by: Alliant Inc.

TURN MOVEMENT COUNT

File Name : TH-61 at Roselawn Ave 2008

Site Code : 00000101

Start Date : 9/18/2008

Page No : 1

Groups Printed- Unshifted

Start Time	TH-61 Southbound				Park Entrance Westbound				TH-61 Northbound				Roselawn Ave. Eastbound				Int. Total
	Left	Thru	Right	Peds	Left	Thru	Right	Peds	Left	Thru	Right	Peds	Left	Thru	Right	Peds	
06:00	1	44	27	0	0	0	0	0	8	39	0	0	4	0	2	0	125
06:15	0	103	44	0	0	0	0	0	17	74	0	0	6	0	8	0	252
06:30	1	188	77	0	0	0	0	0	30	84	0	0	8	0	5	0	393
06:45	0	301	82	0	0	0	0	0	26	100	0	0	14	0	12	0	535
Total	2	636	230	0	0	0	0	0	81	297	0	0	32	0	27	0	1305
07:00	1	314	110	0	0	0	0	0	28	88	0	0	19	0	13	0	573
07:15	1	365	145	0	0	0	0	0	58	114	0	0	20	0	23	0	726
07:30	0	460	161	0	0	0	0	0	52	122	0	0	20	0	26	0	841
07:45	0	423	157	0	0	0	0	0	33	109	0	0	34	0	25	0	781
Total	2	1562	573	0	0	0	0	0	171	433	0	0	93	0	87	0	2921
08:00	1	348	122	0	0	0	0	0	27	128	0	0	23	0	19	0	668
08:15	1	246	134	0	0	0	0	0	34	95	0	0	18	0	10	0	538
08:30	0	267	86	0	0	0	0	0	36	113	0	0	30	0	18	0	550
08:45	1	209	94	0	0	0	0	0	30	120	0	0	34	0	23	0	511
Total	3	1070	436	0	0	0	0	0	127	456	0	0	105	0	70	0	2267
09:00	0	146	59	0	0	0	0	0	15	108	0	0	21	0	14	0	363
09:15	0	132	67	0	0	0	0	0	12	107	0	0	24	0	19	0	361
*** BREAK ***																	
Total	0	278	126	0	0	0	0	0	27	215	0	0	45	0	33	0	724
*** BREAK ***																	
10:30	2	94	28	0	0	0	0	0	17	111	0	0	23	0	9	0	284
10:45	0	127	26	0	0	0	0	0	13	97	0	0	28	0	13	0	304
Total	2	221	54	0	0	0	0	0	30	208	0	0	51	0	22	0	588
11:00	3	120	30	0	0	0	0	0	12	118	0	0	34	0	14	0	331
11:15	4	107	24	0	0	0	0	0	13	103	0	0	50	0	15	0	316
11:30	2	101	38	0	0	0	0	0	14	110	0	0	24	0	13	0	302
11:45	0	107	38	0	0	0	0	0	15	121	0	0	33	0	17	0	331
Total	9	435	130	0	0	0	0	0	54	452	0	0	141	0	59	0	1280
12:00	1	126	27	0	0	0	0	0	12	144	0	0	43	0	20	0	373
12:15	4	115	35	0	0	0	0	0	9	117	0	0	45	0	18	0	343
12:30	1	135	45	0	0	0	0	0	21	118	0	0	32	0	11	0	363
12:45	0	126	40	0	0	0	0	0	18	122	0	0	30	0	12	0	348
Total	6	502	147	0	0	0	0	0	60	501	0	0	150	0	61	0	1427
13:00	3	104	43	0	0	0	0	0	17	121	0	0	25	0	18	0	331
13:15	3	103	26	0	0	0	0	0	6	103	0	0	28	0	18	0	287
*** BREAK ***																	
Total	6	207	69	0	0	0	0	0	23	224	0	0	53	0	36	0	618
*** BREAK ***																	
14:30	1	111	36	0	0	0	0	0	15	180	0	0	39	0	35	0	417
14:45	1	168	38	0	0	0	0	0	16	153	0	0	45	0	19	0	440
Total	2	279	74	0	0	0	0	0	31	333	0	0	84	0	54	0	857
15:00	1	153	41	0	0	0	0	0	24	186	0	0	53	0	35	0	493
15:15	1	137	35	0	0	0	0	0	32	214	0	0	69	0	51	0	539
15:30	1	150	40	0	0	0	0	0	24	246	1	0	67	0	37	1	567
15:45	0	172	43	0	0	0	1	0	32	293	0	0	83	0	42	1	667
Total	3	612	159	0	0	0	1	0	112	939	1	0	272	0	165	2	2266



MINNESOTA DEPT OF TRANSPORTATION

TRAFFIC DATA COLLECTION - METRO

TH-61 at Roselawn Ave. (Maplewood)

Ref.Pt.: 140.566

Data by: Alliant Inc.

TURN MOVEMENT COUNT

File Name : TH-61 at Roselawn Ave 2008

Site Code : 00000101

Start Date : 9/18/2008

Page No : 2

Groups Printed- Unshifted

Start Time	TH-61 Southbound				Park Entrance Westbound				TH-61 Northbound				Roselawn Ave. Eastbound				Int. Total
	Left	Thru	Right	Peds	Left	Thru	Right	Peds	Left	Thru	Right	Peds	Left	Thru	Right	Peds	
16:00	0	184	52	0	0	0	0	0	25	275	0	0	70	0	45	0	651
16:15	0	154	60	0	0	0	0	0	23	306	0	0	86	0	39	0	668
16:30	0	206	54	0	0	0	0	0	27	335	0	0	84	0	50	1	757
16:45	1	204	67	0	0	0	0	0	28	368	0	0	94	0	31	0	793
Total	1	748	233	0	0	0	0	0	103	1284	0	0	334	0	165	1	2869
17:00	1	176	67	0	0	0	0	0	27	377	0	0	81	0	51	0	780
17:15	1	198	66	1	0	0	0	0	41	367	0	0	81	0	39	0	794
17:30	3	184	93	0	0	0	0	0	26	273	0	0	107	0	33	0	719
17:45	3	151	42	0	0	0	0	0	30	274	0	0	89	0	43	0	632
Total	8	709	268	1	0	0	0	0	124	1291	0	0	358	0	166	0	2925
Grand Total	44	7259	2499	1	0	0	1	0	943	6633	1	0	1718	0	945	3	20047
Apprch %	0.4	74	25.5	0	0	0	100	0	12.4	87.5	0	0	64.4	0	35.4	0.1	
Total %	0.2	36.2	12.5	0	0	0	0	0	4.7	33.1	0	0	8.6	0	4.7	0	



MINNESOTA DEPT OF TRANSPORTATION

TRAFFIC DATA COLLECTION - METRO

TH-61 at Roselawn Ave. (Maplewood)

Ref.Pt.: 140.566

Data by: Alliant Inc.

TURN MOVEMENT COUNT

File Name : TH-61 at Roselawn Ave 2008

Site Code : 00000101

Start Date : 9/18/2008

Page No : 3

Start Time	TH-61 Southbound					Park Entrance Westbound					TH-61 Northbound					Roselawn Ave. Eastbound					Int. Total
	Left	Thru	Right	Peds	App. Total	Left	Thru	Right	Peds	App. Total	Left	Thru	Right	Peds	App. Total	Left	Thru	Right	Peds	App. Total	
Peak Hour Analysis From 06:00 to 09:15 - Peak 1 of 1																					
Peak Hour for Entire Intersection Begins at 07:15																					
07:15	1	365	145	0	511	0	0	0	0	0	58	114	0	0	172	20	0	23	0	43	726
07:30	0	460	161	0	621	0	0	0	0	0	52	122	0	0	174	20	0	26	0	46	841
07:45	0	423	157	0	580	0	0	0	0	0	33	109	0	0	142	34	0	25	0	59	781
08:00	1	348	122	0	471	0	0	0	0	0	27	128	0	0	155	23	0	19	0	42	668
Total Volume	2	1596	585	0	2183	0	0	0	0	0	170	473	0	0	643	97	0	93	0	190	3016
% App. Total	0.1	73.1	26.8	0		0	0	0	0		26.4	73.6	0	0		51.1	0	48.9	0		
PHF	.500	.867	.908	.000	.879	.000	.000	.000	.000	.000	.733	.924	.000	.000	.924	.713	.000	.894	.000	.805	.897

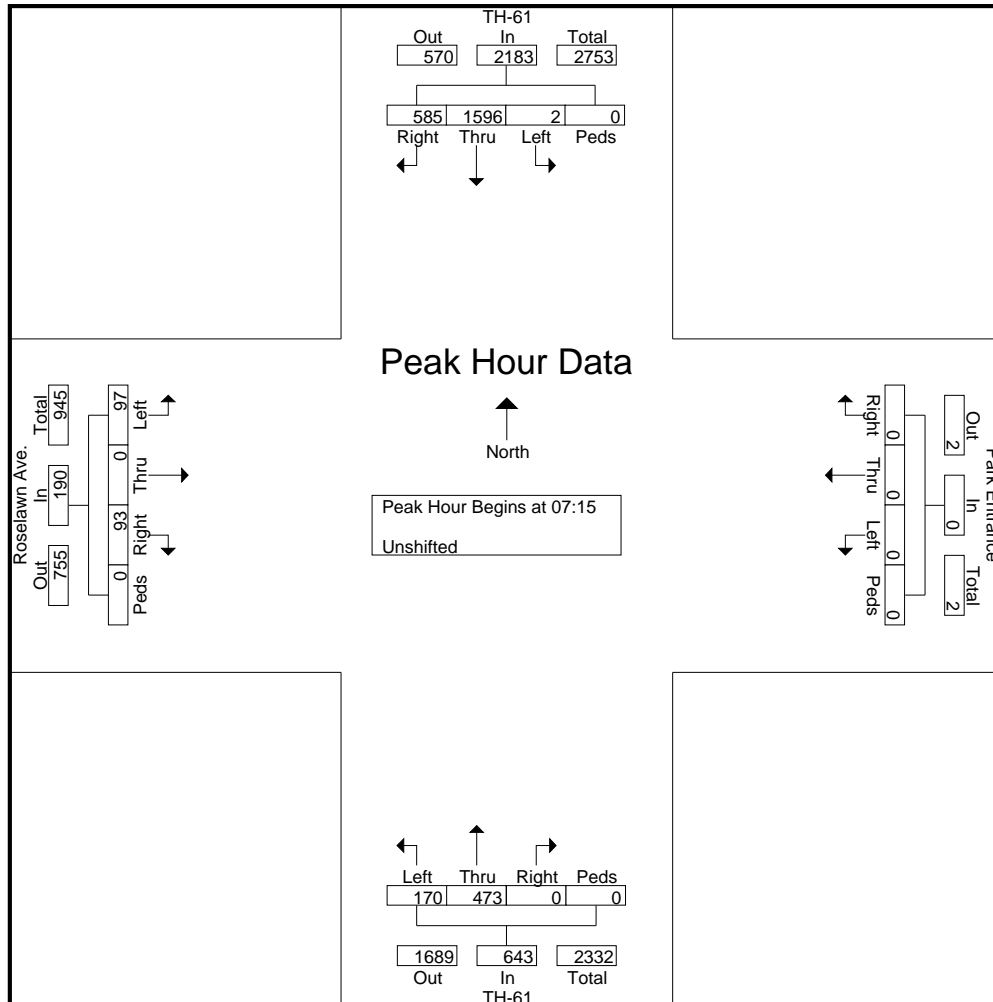



MINNESOTA DEPT OF TRANSPORTATION

TRAFFIC DATA COLLECTION - METRO

TH-61 at Roselawn Ave. (Maplewood)

Ref.Pt.: 140.566

Data by: Alliant Inc.

TURN MOVEMENT COUNT

File Name : TH-61 at Roselawn Ave 2008

Site Code : 00000101

Start Date : 9/18/2008

Page No : 4

Start Time	TH-61 Southbound					Park Entrance Westbound					TH-61 Northbound					Roselawn Ave. Eastbound					Int. Total
	Left	Thru	Right	Peds	App. Total	Left	Thru	Right	Peds	App. Total	Left	Thru	Right	Peds	App. Total	Left	Thru	Right	Peds	App. Total	

Peak Hour Analysis From 14:30 to 17:45 - Peak 1 of 1

Peak Hour for Entire Intersection Begins at 16:30

16:30	0	206	54	0	260	0	0	0	0	0	27	335	0	0	362	84	0	50	1	135	757
16:45	1	204	67	0	272	0	0	0	0	0	28	368	0	0	396	94	0	31	0	125	793
17:00	1	176	67	0	244	0	0	0	0	0	27	377	0	0	404	81	0	51	0	132	780
17:15	1	198	66	1	266	0	0	0	0	0	41	367	0	0	408	81	0	39	0	120	794
Total Volume	3	784	254	1	1042	0	0	0	0	0	123	1447	0	0	1570	340	0	171	1	512	3124
% App. Total	0.3	75.2	24.4	0.1		0	0	0	0		7.8	92.2	0	0		66.4	0	33.4	0.2		
PHF	.750	.951	.948	.250	.958	.000	.000	.000	.000	.000	.750	.960	.000	.000	.962	.904	.000	.838	.250	.948	.984

