



MINNESOTA DEPT OF TRANSPORTATION

TRAFFIC DATA COLLECTION - METRO

TH-61 at Parkway Dr (Frost Ave)

Ref.Pt.: 140.275

Data by: Alliant Inc.

TURN MOVEMENT COUNT

File Name : TH-61 at Parkway Dr - Frost Ave 2008

Site Code : 00000100

Start Date : 9/18/2008

Page No : 1

Groups Printed- Unshifted

Start Time	TH-61 Southbound				Parkway Dr. (Frost Ave) Westbound				TH-61 Northbound				Parkway Dr. (Frost Ave) Eastbound				Int. Total
	Left	Thru	Right	Peds	Left	Thru	Right	Peds	Left	Thru	Right	Peds	Left	Thru	Right	Peds	
06:00	4	45	23	0	1	30	14	0	0	27	1	0	6	6	0	0	157
06:15	4	89	23	0	3	55	12	0	0	68	1	0	11	7	0	0	273
06:30	0	143	100	0	7	82	28	0	0	76	7	0	10	10	2	0	465
06:45	4	162	110	0	8	86	21	0	0	83	6	0	22	14	0	0	516
Total	12	439	256	0	19	253	75	0	0	254	15	0	49	37	2	0	1411
07:00	11	205	135	0	8	103	25	0	0	73	4	1	19	12	1	1	598
07:15	10	235	162	0	8	125	44	0	3	112	5	0	16	17	2	1	740
07:30	11	291	166	0	11	135	44	1	0	99	0	0	30	15	1	0	804
07:45	8	259	143	0	7	109	29	0	0	85	3	0	29	24	2	0	698
Total	40	990	606	0	34	472	142	1	3	369	12	1	94	68	6	2	2840
08:00	14	185	110	0	9	88	29	0	0	88	10	0	38	25	0	0	596
08:15	11	142	84	0	10	85	25	0	0	85	5	0	20	24	0	1	492
08:30	6	159	89	0	4	52	29	0	0	96	6	0	25	20	1	0	487
08:45	19	127	48	0	6	45	22	0	1	106	6	0	22	15	0	0	417
Total	50	613	331	0	29	270	105	0	1	375	27	0	105	84	1	1	1992
09:00	11	102	54	0	7	47	21	0	2	93	4	0	17	22	0	0	380
09:15	17	88	45	1	4	29	22	0	0	78	12	0	18	21	0	0	335
*** BREAK ***																	
Total	28	190	99	1	11	76	43	0	2	171	16	0	35	43	0	0	715
*** BREAK ***																	
10:30	11	58	38	0	4	16	23	0	0	79	11	0	26	14	1	0	281
10:45	12	83	28	0	4	25	11	0	1	74	5	0	26	23	0	0	292
Total	23	141	66	0	8	41	34	0	1	153	16	0	52	37	1	0	573
11:00	17	74	21	0	5	24	20	0	0	87	12	0	23	28	0	0	311
11:15	12	83	30	0	4	37	12	0	1	75	4	0	29	36	2	0	325
11:30	15	71	29	0	4	37	15	0	1	88	12	0	21	23	0	0	316
11:45	15	73	29	0	9	30	18	0	0	82	7	0	36	38	0	0	337
Total	59	301	109	0	22	128	65	0	2	332	35	0	109	125	2	0	1289
12:00	27	87	34	0	5	28	20	0	1	94	6	0	42	37	0	0	381
12:15	20	90	29	0	6	17	8	0	2	91	5	0	27	42	2	0	339
12:30	18	95	28	0	9	29	20	0	1	89	8	0	31	29	0	0	357
12:45	9	99	45	0	10	36	17	0	1	91	7	0	32	30	1	0	378
Total	74	371	136	0	30	110	65	0	5	365	26	0	132	138	3	0	1455
13:00	16	84	30	0	5	27	15	0	1	91	9	0	30	25	0	1	334
13:15	16	91	39	0	7	28	12	0	0	70	8	0	27	25	0	0	323
*** BREAK ***																	
Total	32	175	69	0	12	55	27	0	1	161	17	0	57	50	0	1	657
*** BREAK ***																	
14:30	23	87	26	0	11	24	10	1	3	146	7	0	50	43	0	0	431
14:45	25	130	36	0	7	25	23	0	1	123	18	1	36	58	0	0	483
Total	48	217	62	0	18	49	33	1	4	269	25	1	86	101	0	0	914
15:00	28	117	40	2	7	40	28	0	3	130	10	0	52	40	1	2	500
15:15	44	112	25	0	3	49	32	0	3	169	14	0	63	52	0	0	566
15:30	34	116	37	0	13	42	24	0	4	179	17	2	70	74	1	1	614
15:45	40	131	42	0	11	36	19	0	2	187	19	0	92	95	0	1	675
Total	146	476	144	2	34	167	103	0	12	665	60	2	277	261	2	4	2355



MINNESOTA DEPT OF TRANSPORTATION

TRAFFIC DATA COLLECTION - METRO

TH-61 at Parkway Dr (Frost Ave)

Ref.Pt.: 140.275

Data by: Alliant Inc.

TURN MOVEMENT COUNT

File Name : TH-61 at Parkway Dr - Frost Ave 2008

Site Code : 00000100

Start Date : 9/18/2008

Page No : 2

Groups Printed- Unshifted

Start Time	TH-61 Southbound				Parkway Dr. (Frost Ave) Westbound				TH-61 Northbound				Parkway Dr. (Frost Ave) Eastbound				Int. Total
	Left	Thru	Right	Peds	Left	Thru	Right	Peds	Left	Thru	Right	Peds	Left	Thru	Right	Peds	
16:00	30	121	54	0	10	40	22	0	1	179	14	0	93	72	0	0	636
16:15	32	146	30	1	7	38	25	0	1	201	22	0	106	80	0	1	690
16:30	46	142	62	1	9	25	26	0	2	222	21	0	110	109	1	1	777
16:45	29	128	61	0	6	43	32	1	1	229	17	1	134	103	1	0	786
Total	137	537	207	2	32	146	105	1	5	831	74	1	443	364	2	2	2889
17:00	48	134	56	1	8	44	28	1	1	240	33	0	111	106	0	1	812
17:15	42	141	53	0	7	43	40	0	6	249	30	1	117	91	1	0	821
17:30	37	137	44	0	10	39	31	0	2	205	28	0	110	85	0	0	728
17:45	31	113	41	0	10	41	34	0	0	191	32	0	68	80	1	0	642
Total	158	525	194	1	35	167	133	1	9	885	123	1	406	362	2	1	3003
Grand Total	807	4975	2279	6	284	1934	930	4	45	4830	446	6	1845	1670	21	11	20093
Apprch %	10	61.7	28.3	0.1	9	61.4	29.5	0.1	0.8	90.7	8.4	0.1	52	47.1	0.6	0.3	
Total %	4	24.8	11.3	0	1.4	9.6	4.6	0	0.2	24	2.2	0	9.2	8.3	0.1	0.1	



MINNESOTA DEPT OF TRANSPORTATION

TRAFFIC DATA COLLECTION - METRO

TH-61 at Parkway Dr (Frost Ave)
 Ref.Pt.: 140.275
 Data by: Alliant Inc.
 TURN MOVEMENT COUNT

File Name : TH-61 at Parkway Dr - Frost Ave 2008
 Site Code : 00000100
 Start Date : 9/18/2008
 Page No : 3

Start Time	TH-61 Southbound					Parkway Dr. (Frost Ave) Westbound					TH-61 Northbound					Parkway Dr. (Frost Ave) Eastbound					Int. Total
	Left	Thru	Right	Peds	App. Total	Left	Thru	Right	Peds	App. Total	Left	Thru	Right	Peds	App. Total	Left	Thru	Right	Peds	App. Total	
Peak Hour Analysis From 06:00 to 09:15 - Peak 1 of 1																					
Peak Hour for Entire Intersection Begins at 07:00																					
07:00	11	205	135	0	351	8	103	25	0	136	0	73	4	1	78	19	12	1	1	33	598
07:15	10	235	162	0	407	8	125	44	0	177	3	112	5	0	120	16	17	2	1	36	740
07:30	11	291	166	0	468	11	135	44	1	191	0	99	0	0	99	30	15	1	0	46	804
07:45	8	259	143	0	410	7	109	29	0	145	0	85	3	0	88	29	24	2	0	55	698
Total Volume	40	990	606	0	1636	34	472	142	1	649	3	369	12	1	385	94	68	6	2	170	2840
% App. Total	2.4	60.5	37	0		5.2	72.7	21.9	0.2		0.8	95.8	3.1	0.3		55.3	40	3.5	1.2		
PHF	.909	.851	.913	.000	.874	.773	.874	.807	.250	.849	.250	.824	.600	.250	.802	.783	.708	.750	.500	.773	.883

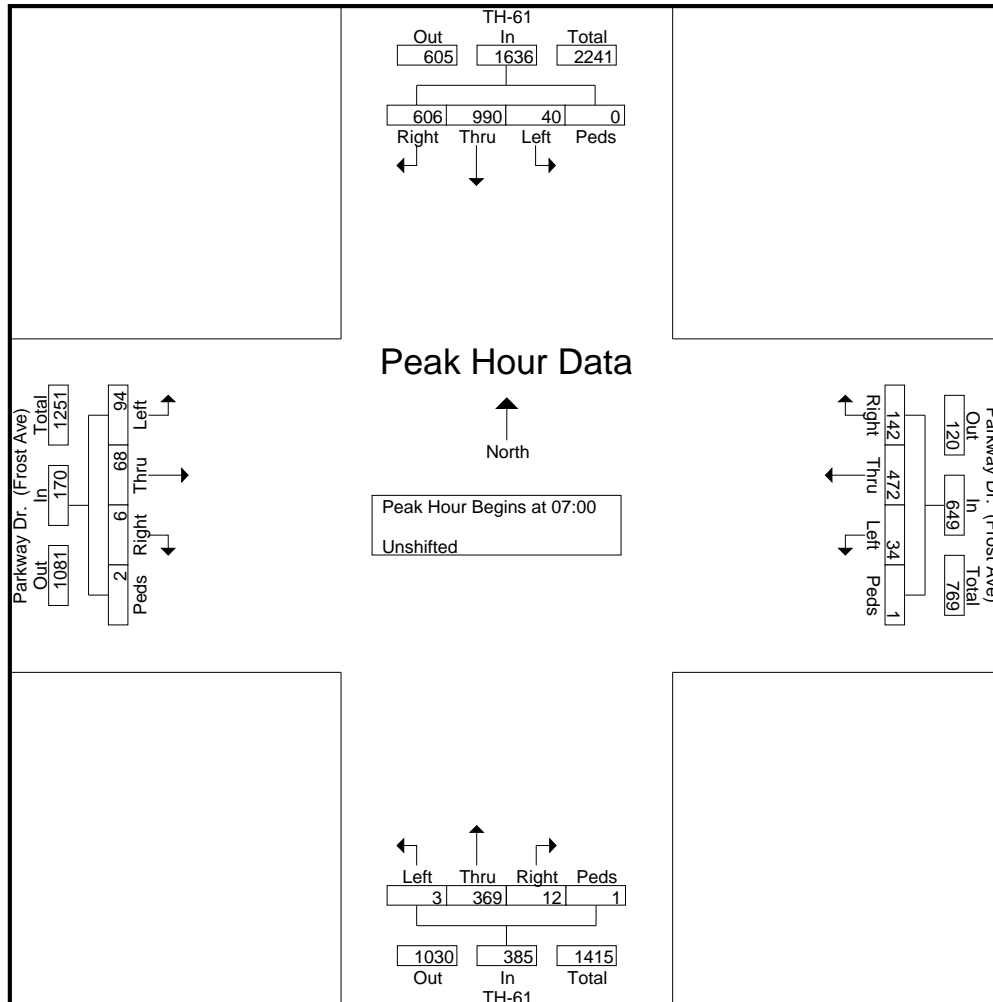



MINNESOTA DEPT OF TRANSPORTATION

TRAFFIC DATA COLLECTION - METRO

TH-61 at Parkway Dr (Frost Ave)
 Ref.Pt.: 140.275
 Data by: Alliant Inc.
 TURN MOVEMENT COUNT

File Name : TH-61 at Parkway Dr - Frost Ave 2008
 Site Code : 00000100
 Start Date : 9/18/2008
 Page No : 4

Start Time	TH-61 Southbound					Parkway Dr. (Frost Ave) Westbound					TH-61 Northbound					Parkway Dr. (Frost Ave) Eastbound					Int. Total
	Left	Thru	Right	Peds	App. Total	Left	Thru	Right	Peds	App. Total	Left	Thru	Right	Peds	App. Total	Left	Thru	Right	Peds	App. Total	

Peak Hour Analysis From 14:30 to 17:45 - Peak 1 of 1

Peak Hour for Entire Intersection Begins at 16:30

16:30	46	142	62	1	251	9	25	26	0	60	2	222	21	0	245	110	109	1	1	221	777
16:45	29	128	61	0	218	6	43	32	1	82	1	229	17	1	248	134	103	1	0	238	786
17:00	48	134	56	1	239	8	44	28	1	81	1	240	33	0	274	111	106	0	1	218	812
17:15	42	141	53	0	236	7	43	40	0	90	6	249	30	1	286	117	91	1	0	209	821
Total Volume	165	545	232	2	944	30	155	126	2	313	10	940	101	2	1053	472	409	3	2	886	3196
% App. Total	17.5	57.7	24.6	0.2		9.6	49.5	40.3	0.6		0.9	89.3	9.6	0.2		53.3	46.2	0.3	0.2		
PHF	.859	.960	.935	.500	.940	.833	.881	.788	.500	.869	.417	.944	.765	.500	.920	.881	.938	.750	.500	.931	.973

