



MINNESOTA DEPT OF TRANSPORTATION

TRAFFIC DATA COLLECTION - METRO

TH-61 AT 15TH ST. (HASTINGS)

REF.PT.: 116.575

JAMAR# 631 RE

TURN MOVEMENT COUNT

File Name : TH-61 AT 15TH ST HASTINGS ampm

Site Code : 00000000

Start Date : 2/8/2006

Page No : 1

Groups Printed- Cars & Trucks

Start Time	TH-61 Southbound				15TH ST Westbound				TH-61 Northbound				15TH ST Eastbound				Int. Total
	Left	Thru	Right	Peds	Left	Thru	Right	Peds	Left	Thru	Right	Peds	Left	Thru	Right	Peds	
06:00	1	72	4	0	0	6	9	0	34	134	0	0	14	4	8	0	286
06:15	3	82	4	0	1	6	6	0	34	153	2	0	13	7	7	0	318
06:30	3	96	4	0	11	6	6	0	23	186	5	0	20	13	11	0	384
06:45	4	127	8	0	3	8	2	1	27	193	3	0	18	17	22	0	433
Total	11	377	20	0	15	26	23	1	118	666	10	0	65	41	48	0	1421
07:00	1	115	6	0	11	10	5	0	50	193	3	0	25	10	15	0	444
07:15	1	116	5	0	13	12	11	0	37	218	2	0	35	8	23	0	481
07:30	2	134	7	0	4	14	6	1	54	205	2	0	34	25	32	0	520
07:45	1	122	10	0	4	8	4	0	19	186	0	0	21	12	27	0	414
Total	5	487	28	0	32	44	26	1	160	802	7	0	115	55	97	0	1859
08:00	4	108	13	0	5	4	2	0	20	142	3	0	14	3	21	0	339
08:15	2	107	4	0	8	11	9	0	26	148	4	0	24	15	19	0	377
08:30	3	136	15	0	15	11	2	0	32	140	8	0	14	18	18	0	412
08:45	4	126	14	0	9	29	8	0	29	132	7	0	14	12	30	0	414
Total	13	477	46	0	37	55	21	0	107	562	22	0	66	48	88	0	1542
15:00	7	182	12	1	20	34	5	0	36	168	4	0	24	18	25	1	537
15:15	6	192	19	0	20	23	6	0	40	158	1	0	24	14	35	0	538
15:30	12	234	12	1	24	11	6	0	41	175	5	0	33	18	43	0	615
15:45	5	245	21	0	15	13	8	0	24	183	4	0	17	14	30	0	579
Total	30	853	64	2	79	81	25	0	141	684	14	0	98	64	133	1	2269
16:00	9	234	23	0	20	12	9	0	25	205	3	0	30	8	37	0	615
16:15	8	231	12	0	22	15	3	0	38	137	2	0	31	14	36	0	549
16:30	6	259	18	0	18	26	7	0	40	225	8	1	32	7	32	0	679
16:45	6	259	29	0	14	19	2	1	58	198	7	0	32	14	58	0	697
Total	29	983	82	0	74	72	21	1	161	765	20	1	125	43	163	0	2540
17:00	4	238	21	1	27	19	10	1	48	213	5	1	23	14	51	1	677
17:15	2	218	17	0	26	17	3	0	37	176	4	0	36	17	50	0	603
17:30	4	217	19	2	9	14	2	0	36	186	2	1	19	11	48	0	570
17:45	2	193	19	1	25	15	7	2	35	177	7	0	30	10	47	2	572
Total	12	866	76	4	87	65	22	3	156	752	18	2	108	52	196	3	2422
Grand Total	100	4043	316	6	324	343	138	6	843	4231	91	3	577	303	725	4	12053
Apprch %	2.2	90.5	7.1	0.1	40	42.3	17	0.7	16.3	81.9	1.8	0.1	35.9	18.8	45.1	0.2	
Total %	0.8	33.5	2.6	0	2.7	2.8	1.1	0	7	35.1	0.8	0	4.8	2.5	6	0	



MINNESOTA DEPT OF TRANSPORTATION

TRAFFIC DATA COLLECTION - METRO

TH-61 AT 15TH ST. (HASTINGS)

REF.PT.: 116.575

JAMAR# 631 RE

TURN MOVEMENT COUNT

File Name : TH-61 AT 15TH ST HASTINGS ampm

Site Code : 00000000

Start Date : 2/8/2006

Page No : 2

Start Time	TH-61 Southbound					15TH ST Westbound					TH-61 Northbound					15TH ST Eastbound					Int. Total
	Left	Thru	Right	Peds	App. Total	Left	Thru	Right	Peds	App. Total	Left	Thru	Right	Peds	App. Total	Left	Thru	Right	Peds	App. Total	
Peak Hour Analysis From 06:00 to 08:45 - Peak 1 of 1																					
Peak Hour for Entire Intersection Begins at 06:45																					
06:45	4	127	8	0	139	3	8	2	1	14	27	193	3	0	223	18	17	22	0	57	433
07:00	1	115	6	0	122	11	10	5	0	26	50	193	3	0	246	25	10	15	0	50	444
07:15	1	116	5	0	122	13	12	11	0	36	37	218	2	0	257	35	8	23	0	66	481
07:30	2	134	7	0	143	4	14	6	1	25	54	205	2	0	261	34	25	32	0	91	520
Total Volume	8	492	26	0	526	31	44	24	2	101	168	809	10	0	987	112	60	92	0	264	1878
% App. Total	1.5	93.5	4.9	0		30.7	43.6	23.8	2		17	82	1	0		42.4	22.7	34.8	0		
PHF	.500	.918	.813	.000	.920	.596	.786	.545	.500	.701	.778	.928	.833	.000	.945	.800	.600	.719	.000	.725	.903

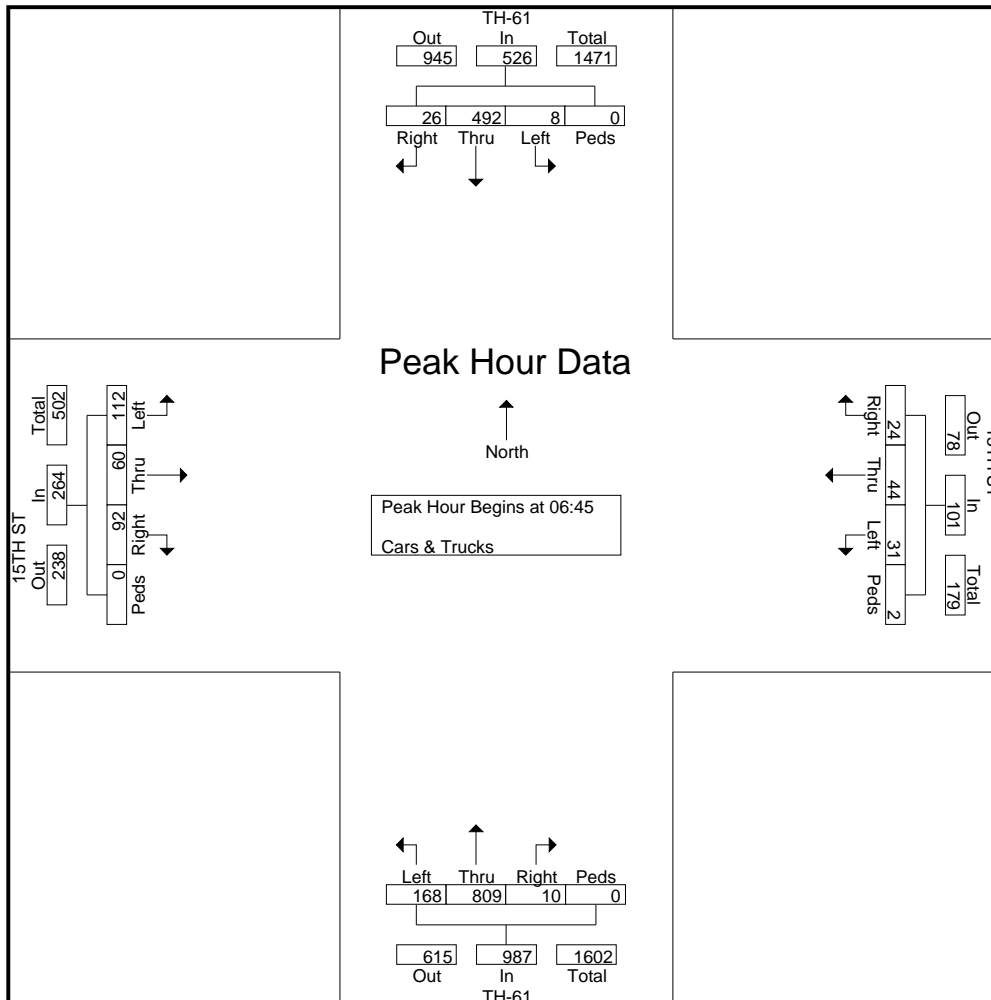



MINNESOTA DEPT OF TRANSPORTATION

TRAFFIC DATA COLLECTION - METRO

TH-61 AT 15TH ST. (HASTINGS)

REF.PT.: 116.575

JAMAR# 631 RE

TURN MOVEMENT COUNT

File Name : TH-61 AT 15TH ST HASTINGS ampm

Site Code : 00000000

Start Date : 2/8/2006

Page No : 3

Start Time	TH-61 Southbound					15TH ST Westbound					TH-61 Northbound					15TH ST Eastbound					Int. Total
	Left	Thru	Right	Peds	App. Total	Left	Thru	Right	Peds	App. Total	Left	Thru	Right	Peds	App. Total	Left	Thru	Right	Peds	App. Total	
Peak Hour Analysis From 15:00 to 17:45 - Peak 1 of 1																					
Peak Hour for Entire Intersection Begins at 16:30																					
16:30	6	259	18	0	283	18	26	7	0	51	40	225	8	1	274	32	7	32	0	71	679
16:45	6	259	29	0	294	14	19	2	1	36	58	198	7	0	263	32	14	58	0	104	697
17:00	4	238	21	1	264	27	19	10	1	57	48	213	5	1	267	23	14	51	1	89	677
17:15	2	218	17	0	237	26	17	3	0	46	37	176	4	0	217	36	17	50	0	103	603
Total Volume	18	974	85	1	1078	85	81	22	2	190	183	812	24	2	1021	123	52	191	1	367	2656
% App. Total	1.7	90.4	7.9	0.1		44.7	42.6	11.6	1.1		17.9	79.5	2.4	0.2		33.5	14.2	52	0.3		
PHF	.750	.940	.733	.250	.917	.787	.779	.550	.500	.833	.789	.902	.750	.500	.932	.854	.765	.823	.250	.882	.953

