

105_TH 55 and Pine Street
Ref. Pt: 219+00.769
data by: Alliant Inc
TURN MOVEMENT COUNT

File Name : 105_TH 55 and Pine Street
Site Code : 00000105
Start Date : 4/18/2019
Page No : 1

Groups Printed- Class 1 - Class 2

Start Time	Pine Street Southbound					TH 55 Westbound					Pine Street Northbound					TH 55 Eastbound					Int. Total
	Other	Rght	Thru	Left	App. Total	Other	Rght	Thru	Left	App. Total	Other	Rght	Thru	Left	App. Total	Other	Rght	Thru	Left	App. Total	
06:00 AM	0	4	4	4	12	0	3	81	2	86	0	6	4	18	28	1	2	58	0	61	187
06:15 AM	0	2	4	1	7	0	3	100	2	105	0	4	6	9	19	0	5	48	1	54	185
06:30 AM	0	3	6	3	12	0	3	168	4	175	0	1	5	22	28	0	6	65	2	73	288
06:45 AM	0	6	9	5	20	0	5	153	14	172	0	4	4	29	37	0	11	71	5	87	316
Total	0	15	23	13	51	0	14	502	22	538	0	15	19	78	112	1	24	242	8	275	976
07:00 AM	0	9	14	3	26	0	4	133	16	153	0	17	12	32	61	2	20	86	1	109	349
07:15 AM	0	3	26	4	33	0	6	226	25	257	1	7	15	49	72	2	20	80	5	107	469
07:30 AM	0	6	28	5	39	0	6	234	48	288	0	11	12	44	67	0	41	123	4	168	562
07:45 AM	0	6	12	6	24	0	5	199	16	220	0	17	8	38	63	0	20	100	4	124	431
Total	0	24	80	18	122	0	21	792	105	918	1	52	47	163	263	4	101	389	14	508	1811
08:00 AM	0	5	6	5	16	0	3	141	7	151	0	3	12	25	40	0	6	67	2	75	282
08:15 AM	0	7	6	6	19	0	2	134	5	141	0	4	5	15	24	0	10	83	4	97	281
08:30 AM	0	7	6	2	15	0	4	150	4	158	0	9	7	25	41	0	10	89	9	108	322
08:45 AM	0	4	5	5	14	0	3	133	7	143	0	6	14	20	40	0	17	94	7	118	315
Total	0	23	23	18	64	0	12	558	23	593	0	22	38	85	145	0	43	333	22	398	1200
09:00 AM	0	5	9	7	21	0	6	113	2	121	0	8	10	16	34	0	11	99	3	113	289
09:15 AM	0	4	8	4	16	0	8	89	1	98	0	7	11	18	36	1	8	103	6	118	268
*** BREAK ***																					
Total	0	9	17	11	37	0	14	202	3	219	0	15	21	34	70	1	19	202	9	231	557
*** BREAK ***																					
10:30 AM	0	7	14	7	28	0	5	116	3	124	0	3	8	19	30	0	18	95	4	117	299
10:45 AM	0	3	6	3	12	0	2	93	6	101	0	2	4	21	27	0	17	100	6	123	263
Total	0	10	20	10	40	0	7	209	9	225	0	5	12	40	57	0	35	195	10	240	562
11:00 AM	0	3	6	2	11	0	1	109	3	113	0	10	5	15	30	0	13	113	3	129	283
11:15 AM	0	3	4	4	11	0	4	121	4	129	0	4	9	19	32	0	8	134	5	147	319
11:30 AM	0	7	17	7	31	0	6	112	3	121	0	3	2	16	21	0	7	145	6	158	331
11:45 AM	0	3	12	4	19	0	4	130	4	138	0	10	11	20	41	1	17	125	4	147	345
Total	0	16	39	17	72	0	15	472	14	501	0	27	27	70	124	1	45	517	18	581	1278
12:00 PM	0	6	6	7	19	0	4	144	2	150	0	1	10	25	36	0	16	150	6	172	377
12:15 PM	0	6	4	7	17	0	3	136	4	143	0	3	21	26	50	0	17	134	3	154	364
12:30 PM	0	4	8	2	14	0	4	131	6	141	0	4	9	19	32	0	16	122	2	140	327
12:45 PM	0	5	24	4	33	0	6	142	6	154	0	6	7	20	33	0	13	138	6	157	377
Total	0	21	42	20	83	0	17	553	18	588	0	14	47	90	151	0	62	544	17	623	1445
01:00 PM	0	6	15	3	24	0	4	107	5	116	0	7	6	30	43	0	16	152	4	172	355
01:15 PM	0	7	4	5	16	0	3	102	3	108	0	10	10	30	50	0	19	109	3	131	305
*** BREAK ***																					
Total	0	13	19	8	40	0	7	209	8	224	0	17	16	60	93	0	35	261	7	303	660
*** BREAK ***																					
02:30 PM	4	5	26	7	42	0	3	130	16	149	0	7	12	25	44	0	26	167	8	201	436
02:45 PM	5	8	13	10	36	0	7	104	11	122	0	16	18	43	77	6	27	146	4	183	418
Total	9	13	39	17	78	0	10	234	27	271	0	23	30	68	121	6	53	313	12	384	854
03:00 PM	0	2	17	7	26	1	7	129	4	141	1	9	6	18	34	0	27	169	6	202	403
03:15 PM	0	9	13	4	26	0	1	137	15	153	0	18	14	34	66	0	21	149	6	176	421
03:30 PM	0	4	21	3	28	0	7	140	13	160	0	14	13	25	52	2	24	179	7	212	452
03:45 PM	0	6	15	7	28	0	9	143	12	164	0	13	14	22	49	0	43	190	10	243	484
Total	0	21	66	21	108	1	24	549	44	618	1	54	47	99	201	2	115	687	29	833	1760

105_TH 55 and Pine Street
Ref. Pt: 219+00.769
data by: Alliant Inc
TURN MOVEMENT COUNT

File Name : 105_TH 55 and Pine Street
Site Code : 00000105
Start Date : 4/18/2019
Page No : 2

Groups Printed- Class 1 - Class 2

Start Time	Pine Street Southbound					TH 55 Westbound					Pine Street Northbound					TH 55 Eastbound					Int. Total	
	Other	Rght	Thru	Left	App. Total	Other	Rght	Thru	Left	App. Total	Other	Rght	Thru	Left	App. Total	Other	Rght	Thru	Left	App. Total		
04:00 PM	0	10	7	8	25	0	3	142	12	157	0	9	17	21	47	1	20	191	5	217	446	
04:15 PM	0	0	20	5	25	0	4	147	7	158	4	13	17	24	58	1	35	197	7	240	481	
04:30 PM	0	3	23	7	33	0	4	119	14	137	0	8	22	33	63	1	33	204	4	242	475	
04:45 PM	0	9	27	6	42	0	4	134	14	152	0	15	18	30	63	0	37	203	9	249	506	
Total	0	22	77	26	125	0	15	542	47	604	4	45	74	108	231	3	125	795	25	948	1908	
05:00 PM	0	5	15	11	31	0	7	136	8	151	0	10	10	26	46	0	37	204	8	249	477	
05:15 PM	0	5	13	4	22	0	7	149	11	167	1	4	10	25	40	1	19	216	10	246	475	
05:30 PM	0	6	16	3	25	0	9	137	8	154	0	3	11	26	40	0	34	210	6	250	469	
05:45 PM	1	4	15	6	26	0	3	114	7	124	0	11	16	23	50	0	32	187	6	225	425	
Total	1	20	59	24	104	0	26	536	34	596	1	28	47	100	176	1	122	817	30	970	1846	
Grand Total	10	207	504	203	924	1	182	5358	354	5895	7	317	425	995	1744	19	779	5295	201	6294	14857	
Apprch %	1.1	22.4	54.5	22	0	3.1	90.9	6	0.4	18.2	24.4	57.1	0.3	12.4	84.1	3.2						
Total %	0.1	1.4	3.4	1.4	6.2	0	1.2	36.1	2.4	39.7	0	2.1	2.9	6.7	11.7	0.1	5.2	35.6	1.4	42.4		
Class 1	9	202	472	194	877	1	178	5189	351	5719	7	310	421	983	1721	15	762	5132	200	6109	14426	
% Class 1	90	97.6	93.7	95.6	94.9	100	97.8	96.8	99.2	97	100	97.8	99.1	98.8	98.7	78.9	97.8	96.9	99.5	97.1	97.1	
Class 2	1	5	32	9	47	0	4	169	3	176	0	7	4	12	23	4	17	163	1	185	431	
% Class 2	10	2.4	6.3	4.4	5.1	0	2.2	3.2	0.8	3	0	2.2	0.9	1.2	1.3	21.1	2.2	3.1	0.5	2.9	2.9	

105_TH 55 and Pine Street
 Ref. Pt: 219+00.769
 data by: Alliant Inc
 TURN MOVEMENT COUNT

File Name : 105_TH 55 and Pine Street
 Site Code : 00000105
 Start Date : 4/18/2019
 Page No : 3

Start Time	Pine Street Southbound					TH 55 Westbound					Pine Street Northbound					TH 55 Eastbound					Int. Total
	Other	Rght	Thru	Left	App. Total	Other	Rght	Thru	Left	App. Total	Other	Rght	Thru	Left	App. Total	Other	Rght	Thru	Left	App. Total	
Peak Hour Analysis From 06:00 AM to 11:45 AM - Peak 1 of 1																					
Peak Hour for Entire Intersection Begins at 07:00 AM																					
07:00 AM	0	9	14	3	26	0	4	133	16	153	0	17	12	32	61	2	20	86	1	109	349
07:15 AM	0	3	26	4	33	0	6	226	25	257	1	7	15	49	72	2	20	80	5	107	469
07:30 AM	0	6	28	5	39	0	6	234	48	288	0	11	12	44	67	0	41	123	4	168	562
07:45 AM	0	6	12	6	24	0	5	199	16	220	0	17	8	38	63	0	20	100	4	124	431
Total Volume	0	24	80	18	122	0	21	792	105	918	1	52	47	163	263	4	101	389	14	508	1811
% App. Total	0	19.7	65.6	14.8		0	2.3	86.3	11.4		0.4	19.8	17.9	62		0.8	19.9	76.6	2.8		
PHF	.000	.667	.714	.750	.782	.000	.875	.846	.547	.797	.250	.765	.783	.832	.913	.500	.616	.791	.700	.756	.806

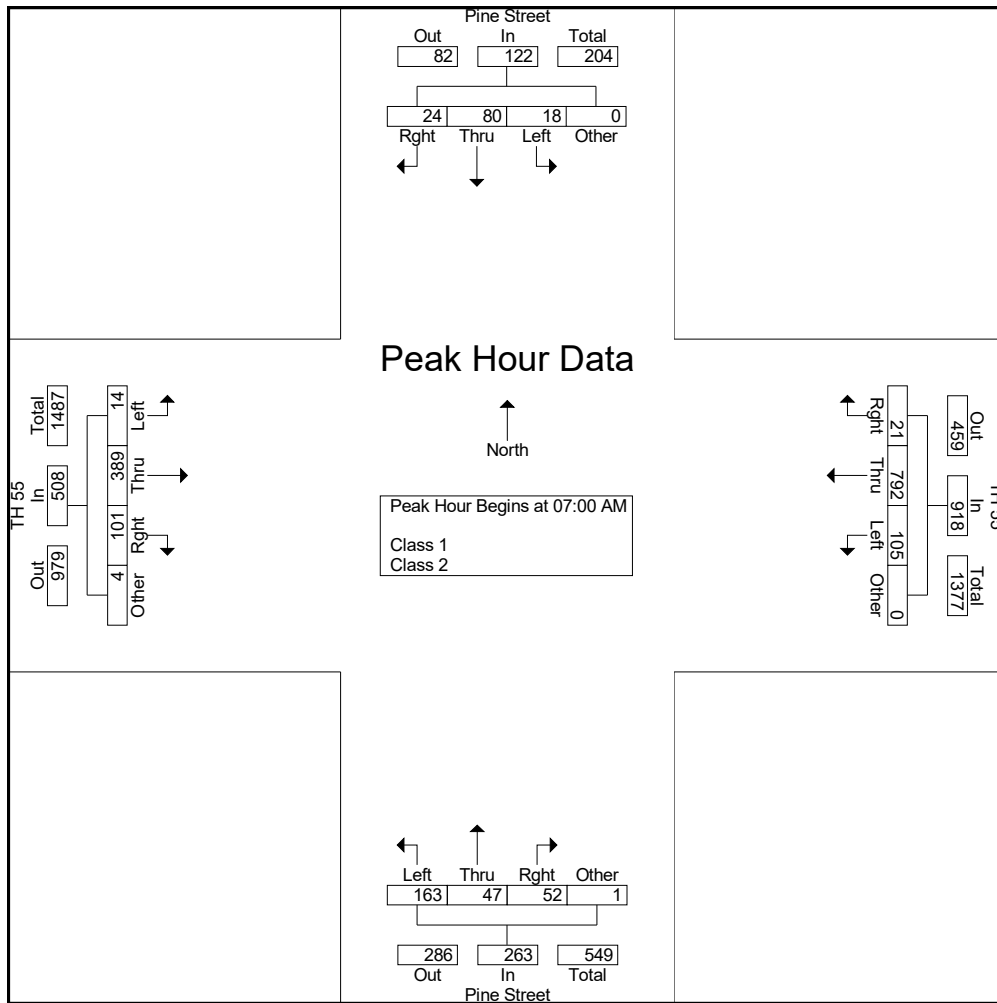

105_TH 55 and Pine Street
 Ref. Pt: 219+00.769
 data by: Alliant Inc
 TURN MOVEMENT COUNT

File Name : 105_TH 55 and Pine Street
 Site Code : 00000105
 Start Date : 4/18/2019
 Page No : 4

Start Time	Pine Street Southbound					TH 55 Westbound					Pine Street Northbound					TH 55 Eastbound					Int. Total
	Other	Rght	Thru	Left	App. Total	Other	Rght	Thru	Left	App. Total	Other	Rght	Thru	Left	App. Total	Other	Rght	Thru	Left	App. Total	
Peak Hour Analysis From 12:00 PM to 05:45 PM - Peak 1 of 1																					
Peak Hour for Entire Intersection Begins at 04:15 PM																					
04:15 PM	0	0	20	5	25	0	4	147	7	158	4	13	17	24	58	1	35	197	7	240	481
04:30 PM	0	3	23	7	33	0	4	119	14	137	0	8	22	33	63	1	33	204	4	242	475
04:45 PM	0	9	27	6	42	0	4	134	14	152	0	15	18	30	63	0	37	203	9	249	506
05:00 PM	0	5	15	11	31	0	7	136	8	151	0	10	10	26	46	0	37	204	8	249	477
Total Volume	0	17	85	29	131	0	19	536	43	598	4	46	67	113	230	2	142	808	28	980	1939
% App. Total	0	13	64.9	22.1		0	3.2	89.6	7.2		1.7	20	29.1	49.1		0.2	14.5	82.4	2.9		
PHF	.000	.472	.787	.659	.780	.000	.679	.912	.768	.946	.250	.767	.761	.856	.913	.500	.959	.990	.778	.984	.958

