



MINNESOTA DEPT OF TRANSPORTATION

TRAFFIC DATA COLLECTION - METRO

TH-55 at TH-149, N jct
 Ref.Pt.: 202.163
 JAMAR # 631 / 632 RE / DR
 TURN MOVEMENT COUNT - AM & PM

File Name : TH-55 at TH-149 N jct 2008 am pm
 Site Code : 00000000
 Start Date : 4/2/2008
 Page No : 1

Groups Printed- Cars & Trucks

Start Time	TH-149 / Dodd Rd. Southbound				TH-55 / TH-149 Westbound				Dodd Rd. Northbound				TH-55 Eastbound				Int. Total
	Left	Thru	Right	Peds	Left	Thru	Right	Peds	Left	Thru	Right	Peds	Left	Thru	Right	Peds	
06:00	63	2	2	0	2	92	56	0	0	1	0	0	8	40	0	0	266
06:15	76	5	3	0	4	159	114	0	1	0	0	0	19	57	2	0	440
06:30	91	9	12	0	2	170	142	1	1	1	0	0	27	67	1	0	524
06:45	109	11	8	0	1	205	130	1	0	1	0	0	20	98	2	0	586
Total	339	27	25	0	9	626	442	2	2	3	0	0	74	262	5	0	1816
07:00	106	7	16	0	1	284	154	0	0	1	1	0	27	88	1	0	686
07:15	132	8	18	0	1	290	202	0	0	2	0	0	33	118	6	0	810
07:30	137	6	20	0	0	305	210	0	1	7	0	0	42	145	8	0	881
07:45	149	11	16	0	2	320	204	0	0	1	0	0	47	153	20	0	923
Total	524	32	70	0	4	1199	770	0	1	11	1	0	149	504	35	0	3300
08:00	123	8	10	0	1	267	157	0	4	2	1	0	33	103	10	0	719
08:15	120	8	17	0	3	202	119	0	1	1	2	0	31	106	6	0	616
08:30	89	11	12	0	0	186	166	0	1	0	1	0	28	127	7	0	628
08:45	84	6	14	0	0	133	149	0	2	1	0	0	18	104	8	0	519
Total	416	33	53	0	4	788	591	0	8	4	4	0	110	440	31	0	2482
*** BREAK ***																	
14:45	72	3	23	0	1	90	111	0	3	1	2	0	22	118	1	0	447
Total	72	3	23	0	1	90	111	0	3	1	2	0	22	118	1	0	447
15:00	81	1	17	0	1	99	132	4	1	3	2	0	21	136	3	0	501
15:15	92	4	26	0	1	97	117	0	0	3	1	0	21	135	2	0	499
15:30	95	4	24	0	0	111	136	0	6	3	5	0	39	144	2	0	569
15:45	72	0	28	0	2	111	129	0	1	4	2	0	21	159	5	0	534
Total	340	9	95	0	4	418	514	4	8	13	10	0	102	574	12	0	2103
16:00	105	3	29	0	0	121	124	12	0	3	1	0	17	196	1	0	612
16:15	122	2	22	0	0	123	175	0	1	6	1	0	27	208	1	0	688
16:30	104	9	35	0	1	149	175	0	8	6	3	0	22	235	1	0	748
16:45	135	6	32	0	2	25	184	3	1	14	5	0	24	237	3	0	671
Total	466	20	118	0	3	418	658	15	10	29	10	0	90	876	6	0	2719
17:00	151	6	42	0	2	191	222	1	10	19	7	0	14	208	4	0	877
17:15	139	3	24	0	5	192	195	0	5	5	1	0	16	231	4	0	820
17:30	117	3	28	0	1	166	140	0	3	3	1	0	16	212	2	0	692
17:45	95	3	11	0	0	159	148	0	2	6	1	0	12	179	1	0	617
Total	502	15	105	0	8	708	705	1	20	33	10	0	58	830	11	0	3006
Grand Total	2659	139	489	0	33	4247	3791	22	52	94	37	0	605	3604	101	0	15873
Apprch %	80.9	4.2	14.9	0	0.4	52.5	46.8	0.3	28.4	51.4	20.2	0	14	83.6	2.3	0	
Total %	16.8	0.9	3.1	0	0.2	26.8	23.9	0.1	0.3	0.6	0.2	0	3.8	22.7	0.6	0	



MINNESOTA DEPT OF TRANSPORTATION

TRAFFIC DATA COLLECTION - METRO

TH-55 at TH-149, N jct
 Ref.Pt.: 202.163
 JAMAR # 631 / 632 RE / DR
 TURN MOVEMENT COUNT - AM & PM

File Name : TH-55 at TH-149 N jct 2008 am pm
 Site Code : 00000000
 Start Date : 4/2/2008
 Page No : 2

Start Time	TH-149 / Dodd Rd. Southbound					TH-55 / TH-149 Westbound					Dodd Rd. Northbound					TH-55 Eastbound					Int. Total
	Left	Thru	Right	Peds	App. Total	Left	Thru	Right	Peds	App. Total	Left	Thru	Right	Peds	App. Total	Left	Thru	Right	Peds	App. Total	
Peak Hour Analysis From 06:00 to 08:45 - Peak 1 of 1																					
Peak Hour for Entire Intersection Begins at 07:15																					
07:15	132	8	18	0	158	1	290	202	0	493	0	2	0	0	2	33	118	6	0	157	810
07:30	137	6	20	0	163	0	305	210	0	515	1	7	0	0	8	42	145	8	0	195	881
07:45	149	11	16	0	176	2	320	204	0	526	0	1	0	0	1	47	153	20	0	220	923
08:00	123	8	10	0	141	1	267	157	0	425	4	2	1	0	7	33	103	10	0	146	719
Total Volume	541	33	64	0	638	4	1182	773	0	1959	5	12	1	0	18	155	519	44	0	718	3333
% App. Total	84.8	5.2	10	0		0.2	60.3	39.5	0		27.8	66.7	5.6	0		21.6	72.3	6.1	0		
PHF	.908	.750	.800	.000	.906	.500	.923	.920	.000	.931	.313	.429	.250	.000	.563	.824	.848	.550	.000	.816	.903

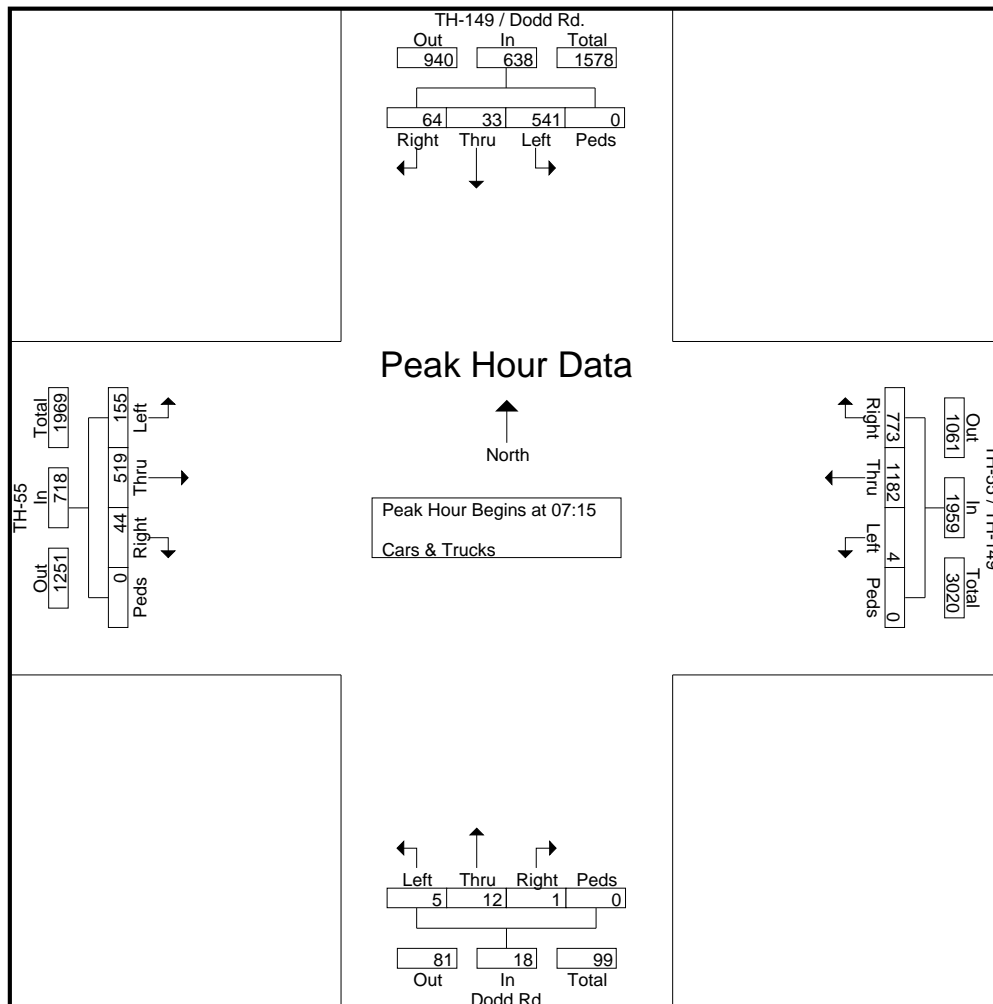



MINNESOTA DEPT OF TRANSPORTATION

TRAFFIC DATA COLLECTION - METRO

TH-55 at TH-149, N jct
 Ref.Pt.: 202.163
 JAMAR # 631 / 632 RE / DR
 TURN MOVEMENT COUNT - AM & PM

File Name : TH-55 at TH-149 N jct 2008 am pm
 Site Code : 00000000
 Start Date : 4/2/2008
 Page No : 3

Start Time	TH-149 / Dodd Rd. Southbound					TH-55 / TH-149 Westbound					Dodd Rd. Northbound					TH-55 Eastbound					Int. Total
	Left	Thru	Right	Peds	App. Total	Left	Thru	Right	Peds	App. Total	Left	Thru	Right	Peds	App. Total	Left	Thru	Right	Peds	App. Total	
Peak Hour Analysis From 14:45 to 17:45 - Peak 1 of 1																					
Peak Hour for Entire Intersection Begins at 16:30																					
16:30	104	9	35	0	148	1	149	175	0	325	8	6	3	0	17	22	235	1	0	258	748
16:45	135	6	32	0	173	2	25	184	3	214	1	14	5	0	20	24	237	3	0	264	671
17:00	151	6	42	0	199	2	191	222	1	416	10	19	7	0	36	14	208	4	0	226	877
17:15	139	3	24	0	166	5	192	195	0	392	5	5	1	0	11	16	231	4	0	251	820
Total Volume	529	24	133	0	686	10	557	776	4	1347	24	44	16	0	84	76	911	12	0	999	3116
% App. Total																					
PHF	.876	.667	.792	.000	.862	.500	.725	.874	.333	.809	.600	.579	.571	.000	.583	.792	.961	.750	.000	.946	.888

