

Alliant Engineering Inc Minneapolis, MN 55415

TH-55 at Northwest Blvd / Xenium Lane
 Ref.Pt.: 180.871
 Alliant Engineering Inc.
 TURN MOVEMENT COUNT

File Name : 49_TH 55 at Xenium Ln_012511
 Site Code : 00000049
 Start Date : 1/25/2011
 Page No : 1

Groups Printed- Unshifted - Bank 1

Start Time	Northwest Blvd / Co.Rd.61 Southbound				TH-55 Westbound				Xenium Lane / Co.Rd.61 Northbound				TH-55 Eastbound				Int. Total
	Left	Thru	Rght	Other	Left	Thru	Rght	Other	Left	Thru	Rght	Other	Left	Thru	Rght	Other	
06:00	18	16	17	0	4	31	9	1	3	5	4	0	28	116	35	0	287
06:15	29	34	27	0	12	57	18	0	4	5	2	0	38	166	39	0	431
06:30	42	38	26	0	5	76	20	0	2	7	1	0	51	253	52	0	573
06:45	64	101	51	0	12	118	32	0	6	24	3	0	81	306	98	0	896
Total	153	189	121	0	33	282	79	1	15	41	10	0	198	841	224	0	2187
07:00	76	94	64	0	14	87	37	0	9	20	4	0	78	339	106	0	928
07:15	123	148	90	0	14	108	60	0	12	31	4	0	97	370	114	0	1171
07:30	96	150	78	0	17	112	59	0	4	42	3	0	104	405	111	0	1181
07:45	109	203	89	0	21	139	79	0	8	57	3	0	111	311	93	0	1223
Total	404	595	321	0	66	446	235	0	33	150	14	0	390	1425	424	0	4503
08:00	62	121	68	0	12	93	30	0	12	40	9	0	135	373	85	0	1040
08:15	48	74	70	0	15	119	34	0	17	54	6	0	134	306	81	1	959
08:30	57	67	68	0	12	86	32	0	12	26	5	0	113	261	52	0	791
08:45	48	52	61	0	14	80	31	0	9	31	8	0	109	219	73	0	735
Total	215	314	267	0	53	378	127	0	50	151	28	0	491	1159	291	1	3525
09:00	29	48	48	0	12	80	15	0	13	40	9	0	81	194	55	2	626
09:15	42	38	61	0	2	83	19	0	13	25	8	0	64	134	28	4	521
*** BREAK ***																	
Total	71	86	109	0	14	163	34	0	26	65	17	0	145	328	83	6	1147
*** BREAK ***																	
10:30	46	43	57	1	7	89	26	0	26	30	10	0	74	88	25	2	524
10:45	29	32	56	0	4	115	27	0	27	33	13	0	61	108	34	0	539
Total	75	75	113	1	11	204	53	0	53	63	23	0	135	196	59	2	1063
11:00	41	42	72	7	9	86	39	0	32	41	15	0	91	100	33	1	609
11:15	42	55	110	0	9	130	58	0	34	50	9	0	96	123	35	0	751
11:30	57	58	104	0	6	131	42	0	41	82	7	0	95	116	45	0	784
11:45	46	62	104	0	6	177	49	0	49	70	22	0	81	115	42	0	823
Total	186	217	390	7	30	524	188	0	156	243	53	0	363	454	155	1	2967
12:00	68	61	102	0	7	137	39	0	62	105	15	0	99	117	36	0	848
12:15	49	78	104	0	11	167	48	0	55	89	12	0	88	123	45	0	869
12:30	56	54	101	0	8	114	48	0	34	71	11	0	101	132	62	0	792
12:45	43	64	87	0	8	170	48	0	45	67	6	0	91	145	62	0	836
Total	216	257	394	0	34	588	183	0	196	332	44	0	379	517	205	0	3345
13:00	55	72	102	0	4	159	38	0	31	64	7	0	110	121	47	0	810
13:15	48	61	63	0	10	161	29	0	36	55	12	0	87	127	39	0	728
*** BREAK ***																	
Total	103	133	165	0	14	320	67	0	67	119	19	0	197	248	86	0	1538
*** BREAK ***																	
14:30	33	36	72	0	6	164	59	0	51	75	10	1	72	168	28	0	775
14:45	33	32	94	0	16	177	54	0	27	58	10	0	79	132	47	0	759
Total	66	68	166	0	22	341	113	0	78	133	20	1	151	300	75	0	1534
15:00	44	32	80	0	20	179	36	0	65	76	19	0	71	136	55	0	813
15:15	50	34	85	0	16	249	34	0	44	77	12	0	64	103	40	0	808
15:30	30	28	104	0	13	242	44	0	105	142	36	0	99	150	25	0	1018
15:45	34	24	89	2	10	267	45	1	44	95	16	0	82	123	29	0	861
Total	158	118	358	2	59	937	159	1	258	390	83	0	316	512	149	0	3500

Alliant Engineering Inc Minneapolis, MN 55415

TH-55 at Northwest Blvd / Xenium Lane
 Ref.Pt.: 180.871
 Alliant Engineering Inc.
 TURN MOVEMENT COUNT

File Name : 49_TH 55 at Xenium Ln_012511
 Site Code : 00000049
 Start Date : 1/25/2011
 Page No : 2

Groups Printed- Unshifted - Bank 1

Start Time	Northwest Blvd / Co.Rd.61 Southbound				TH-55 Westbound				Xenium Lane / Co.Rd.61 Northbound				TH-55 Eastbound				Int. Total
	Left	Thru	Rght	Other	Left	Thru	Rght	Other	Left	Thru	Rght	Other	Left	Thru	Rght	Other	
16:00	63	36	103	0	9	246	66	0	86	115	21	0	70	170	22	0	1007
16:15	51	37	101	0	6	322	56	0	55	125	10	0	84	152	24	0	1023
16:30	65	47	127	0	10	300	45	3	77	210	17	0	79	174	21	0	1175
16:45	60	52	161	0	12	403	75	0	62	180	18	0	77	146	24	0	1270
Total	239	172	492	0	37	1271	242	3	280	630	66	0	310	642	91	0	4475
17:00	85	68	207	0	6	327	50	0	85	167	41	0	95	178	20	0	1329
17:15	67	46	135	0	16	407	59	0	48	221	27	0	81	156	28	0	1291
17:30	37	44	99	0	12	348	64	0	46	137	16	0	73	150	35	0	1061
17:45	35	43	71	0	3	289	98	6	43	89	18	0	64	131	31	0	921
Total	224	201	512	0	37	1371	271	6	222	614	102	0	313	615	114	0	4602
Grand Total	2110	2425	3408	10	410	6825	1751	11	1434	2931	479	1	3388	7237	1956	10	34386
Apprch %	26.5	30.5	42.9	0.1	4.6	75.9	19.5	0.1	29.6	60.5	9.9	0	26.9	57.5	15.5	0.1	
Total %	6.1	7.1	9.9	0	1.2	19.8	5.1	0	4.2	8.5	1.4	0	9.9	21	5.7	0	
Unshifted	2080	2381	3341	8	402	6692	1728	10	1405	2888	472	1	3332	7067	1920	9	33736
% Unshifted	98.6	98.2	98	80	98	98.1	98.7	90.9	98	98.5	98.5	100	98.3	97.7	98.2	90	98.1
Bank 1	30	44	67	2	8	133	23	1	29	43	7	0	56	170	36	1	650
% Bank 1	1.4	1.8	2	20	2	1.9	1.3	9.1	2	1.5	1.5	0	1.7	2.3	1.8	10	1.9

Alliant Engineering Inc Minneapolis, MN 55415

TH-55 at Northwest Blvd / Xenium Lane
 Ref.Pt.: 180.871
 Alliant Engineering Inc.
 TURN MOVEMENT COUNT

File Name : 49_TH 55 at Xenium Ln_012511
 Site Code : 00000049
 Start Date : 1/25/2011
 Page No : 3

Start Time	Northwest Blvd / Co.Rd.61 Southbound					TH-55 Westbound					Xenium Lane / Co.Rd.61 Northbound					TH-55 Eastbound					Int. Total
	Left	Thru	Rght	Other	App. Total	Left	Thru	Rght	Other	App. Total	Left	Thru	Rght	Other	App. Total	Left	Thru	Rght	Other	App. Total	
Peak Hour Analysis From 06:00 to 09:15 - Peak 1 of 1																					
Peak Hour for Entire Intersection Begins at 07:15																					
07:15	123	148	90	0	361	14	108	60	0	182	12	31	4	0	47	97	370	114	0	581	1171
07:30	96	150	78	0	324	17	112	59	0	188	4	42	3	0	49	104	405	111	0	620	1181
07:45	109	203	89	0	401	21	139	79	0	239	8	57	3	0	68	111	311	93	0	515	1223
08:00	62	121	68	0	251	12	93	30	0	135	12	40	9	0	61	135	373	85	0	593	1040
Total Volume	390	622	325	0	1337	64	452	228	0	744	36	170	19	0	225	447	1459	403	0	2309	4615
% App. Total	29.2	46.5	24.3	0		8.6	60.8	30.6	0		16	75.6	8.4	0		19.4	63.2	17.5	0		
PHF	.793	.766	.903	.000	.834	.762	.813	.722	.000	.778	.750	.746	.528	.000	.827	.828	.901	.884	.000	.931	.943

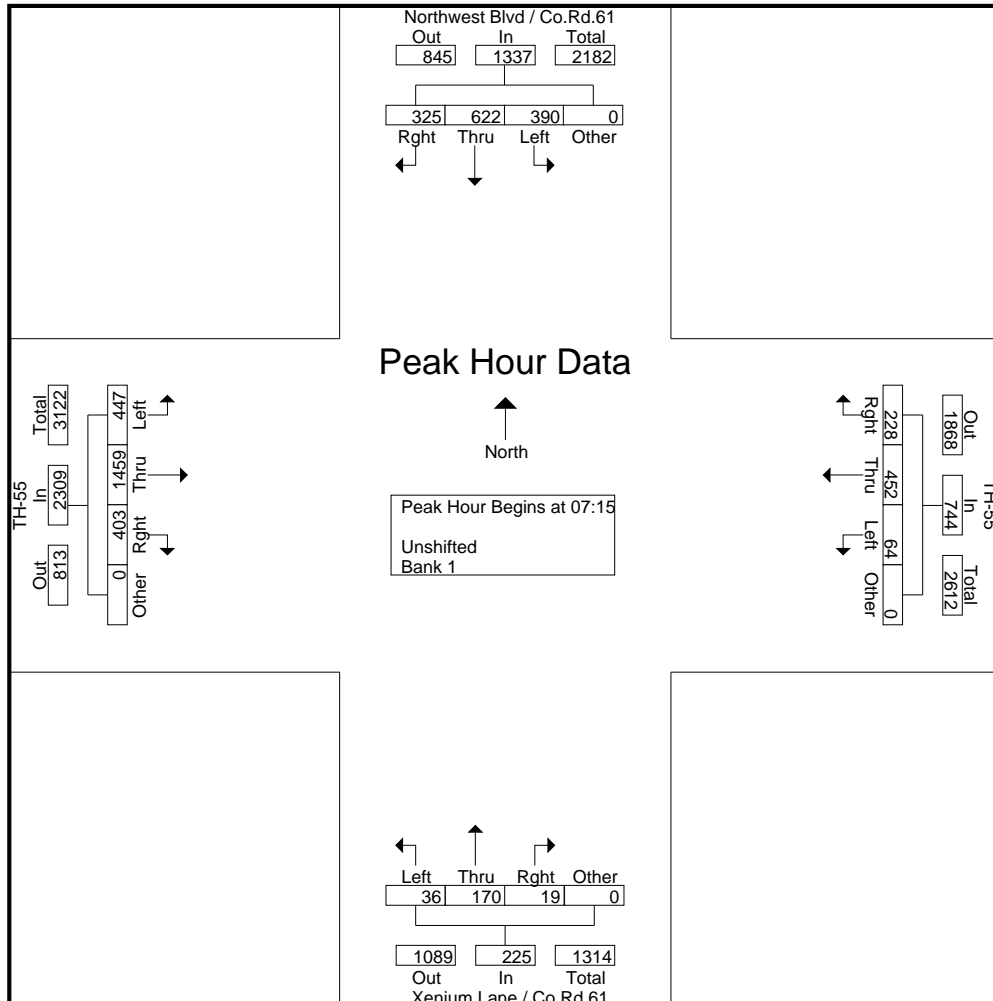

Alliant Engineering Inc Minneapolis, MN 55415

TH-55 at Northwest Blvd / Xenium Lane
 Ref.Pt.: 180.871
 Alliant Engineering Inc.
 TURN MOVEMENT COUNT

File Name : 49_TH 55 at Xenium Ln_012511
 Site Code : 0000049
 Start Date : 1/25/2011
 Page No : 4

Start Time	Northwest Blvd / Co.Rd.61 Southbound					TH-55 Westbound					Xenium Lane / Co.Rd.61 Northbound					TH-55 Eastbound					Int. Total
	Left	Thru	Rght	Other	App. Total	Left	Thru	Rght	Other	App. Total	Left	Thru	Rght	Other	App. Total	Left	Thru	Rght	Other	App. Total	
Peak Hour Analysis From 14:30 to 17:45 - Peak 1 of 1																					
Peak Hour for Entire Intersection Begins at 16:30																					
16:30	65	47	127	0	239	10	300	45	3	358	77	210	17	0	304	79	174	21	0	274	1175
16:45	60	52	161	0	273	12	403	75	0	490	62	180	18	0	260	77	146	24	0	247	1270
17:00	85	68	207	0	360	6	327	50	0	383	85	167	41	0	293	95	178	20	0	293	1329
17:15	67	46	135	0	248	16	407	59	0	482	48	221	27	0	296	81	156	28	0	265	1291
Total Volume	277	213	630	0	1120	44	1437	229	3	1713	272	778	103	0	1153	332	654	93	0	1079	5065
% App. Total	24.7	19	56.2	0		2.6	83.9	13.4	0.2		23.6	67.5	8.9	0		30.8	60.6	8.6	0		
PHF	.815	.783	.761	.000	.778	.688	.883	.763	.250	.874	.800	.880	.628	.000	.948	.874	.919	.830	.000	.921	.953

