



MINNESOTA DEPT OF TRANSPORTATION

TRAFFIC DATA COLLECTION - METRO

Counted By: Ivan & Linda
 Day of the Week: Wednesday
 Location: TH 55 & 494 W Ramp
 Project #: 5764

File Name : TH 55 @ I494 WEST RAMP 2006
 Site Code : 07261112
 Start Date : 7/26/2006
 Page No : 1

Groups Printed- Unshifted

Start Time	494 West Ramp Southbound					TH 55 Westbound					494 West Ramp Northbound					TH 55 Eastbound					Int. Total
	Left	Thru	Right	Peds	App. Total	Left	Thru	Right	Peds	App. Total	Left	Thru	Right	Peds	App. Total	Left	Thru	Right	Peds	App. Total	
06:00	60	0	91	0	151	8	128	0	0	136	0	0	0	0	0	0	179	147	0	326	613
06:15	76	0	90	0	166	5	139	0	0	144	0	0	0	0	0	0	237	188	0	425	735
06:30	81	0	114	0	195	16	243	0	0	259	0	0	0	0	0	0	320	198	0	518	972
06:45	116	0	131	0	247	22	289	0	0	311	0	0	0	0	0	0	429	162	0	591	1149
Total	333	0	426	0	759	51	799	0	0	850	0	0	0	0	0	0	1165	695	0	1860	3469
07:00	124	0	93	0	217	17	263	0	0	280	0	0	0	0	0	0	423	184	0	607	1104
07:15	115	0	105	0	220	18	303	0	0	321	0	0	0	0	0	0	483	139	0	622	1163
07:30	149	0	104	0	253	22	325	0	0	347	0	0	0	0	0	0	508	138	0	646	1246
07:45	135	0	124	0	259	32	392	0	0	424	0	0	0	0	0	0	523	134	0	657	1340
Total	523	0	426	0	949	89	1283	0	0	1372	0	0	0	0	0	0	1937	595	0	2532	4853
08:00	124	0	106	0	230	22	342	0	0	364	0	0	0	0	0	0	470	165	0	635	1229
08:15	94	0	91	0	185	30	300	0	0	330	0	0	0	0	0	0	398	126	0	524	1039
08:30	80	0	87	0	167	31	307	0	0	338	0	0	0	0	0	0	379	135	0	514	1019
08:45	81	0	107	0	188	37	332	0	0	369	0	0	0	0	0	0	329	166	0	495	1052
Total	379	0	391	0	770	120	1281	0	0	1401	0	0	0	0	0	0	1576	592	0	2168	4339
11:00	53	0	77	0	130	48	306	0	0	354	0	0	0	0	0	0	248	160	0	408	892
11:15	50	0	90	0	140	57	382	0	0	439	0	0	0	0	0	0	294	183	0	477	1056
11:30	58	1	100	0	159	55	397	0	0	452	0	0	0	0	0	0	275	181	0	456	1067
11:45	48	0	103	0	151	44	450	0	0	494	0	0	0	0	0	0	296	170	0	466	1111
Total	209	1	370	0	580	204	1535	0	0	1739	0	0	0	0	0	0	1113	694	0	1807	4126
12:00	53	0	94	0	147	62	402	0	0	464	0	0	0	0	0	0	323	150	0	473	1084
12:15	50	0	89	0	139	51	422	0	0	473	0	0	0	0	0	0	330	165	0	495	1107
12:30	49	0	67	0	116	56	399	0	0	455	0	0	0	0	0	0	330	175	0	505	1076
12:45	63	0	79	0	142	49	414	0	0	463	0	0	0	0	0	0	359	182	0	541	1146
Total	215	0	329	0	544	218	1637	0	0	1855	0	0	0	0	0	0	1342	672	0	2014	4413
15:00	43	0	82	0	125	49	412	13	0	474	0	0	0	0	0	0	308	149	0	457	1056
15:15	84	0	50	0	134	60	382	0	0	442	0	0	0	0	0	0	294	174	0	468	1044
15:30	37	0	51	0	88	66	443	62	0	571	0	0	0	0	0	0	416	154	0	570	1229
15:45	45	0	51	0	96	47	484	0	0	531	0	0	0	0	0	0	290	150	0	440	1067
Total	209	0	234	0	443	222	1721	75	0	2018	0	0	0	0	0	0	1308	627	0	1935	4396
16:00	30	0	45	0	75	84	494	0	0	578	0	0	0	0	0	0	382	163	0	545	1198
16:15	33	0	58	0	91	54	528	0	0	582	0	0	0	0	0	0	306	150	0	456	1129
16:30	22	0	47	0	69	72	530	0	2	604	0	0	0	0	0	0	347	199	0	546	1219
16:45	36	1	55	0	92	43	574	2	0	619	0	0	0	0	0	0	297	177	0	474	1185
Total	121	1	205	0	327	253	2126	2	2	2383	0	0	0	0	0	0	1332	689	0	2021	4731
17:00	28	0	42	0	70	66	529	0	0	595	0	0	0	0	0	0	394	187	0	581	1246
17:15	41	1	65	0	107	71	547	0	0	618	0	0	0	0	0	0	323	155	0	478	1203
17:30	40	0	54	0	94	64	549	0	0	613	0	0	0	0	0	0	321	159	0	480	1187
17:45	26	68	55	0	149	57	505	0	0	562	0	0	0	0	0	0	252	106	0	358	1069
Total	135	69	216	0	420	258	2130	0	0	2388	0	0	0	0	0	0	1290	607	0	1897	4705
Grand Total	2124	71	2597	0	4792	1415	12512	77	2	14006	0	0	0	0	0	0	11063	5171	0	16234	35032
Apprch %	44.3	1.5	54.2	0		10.1	89.3	0.5	0		0	0	0	0	0	0	68.1	31.9	0		
Total %	6.1	0.2	7.4	0	13.7	4	35.7	0.2	0	40	0	0	0	0	0	0	31.6	14.8	0	46.3	



MINNESOTA DEPT OF TRANSPORTATION

TRAFFIC DATA COLLECTION - METRO

File Name : TH 55 @ I494 WEST RAMP 2006

Site Code : 07261112

Start Date : 7/26/2006

Page No : 2

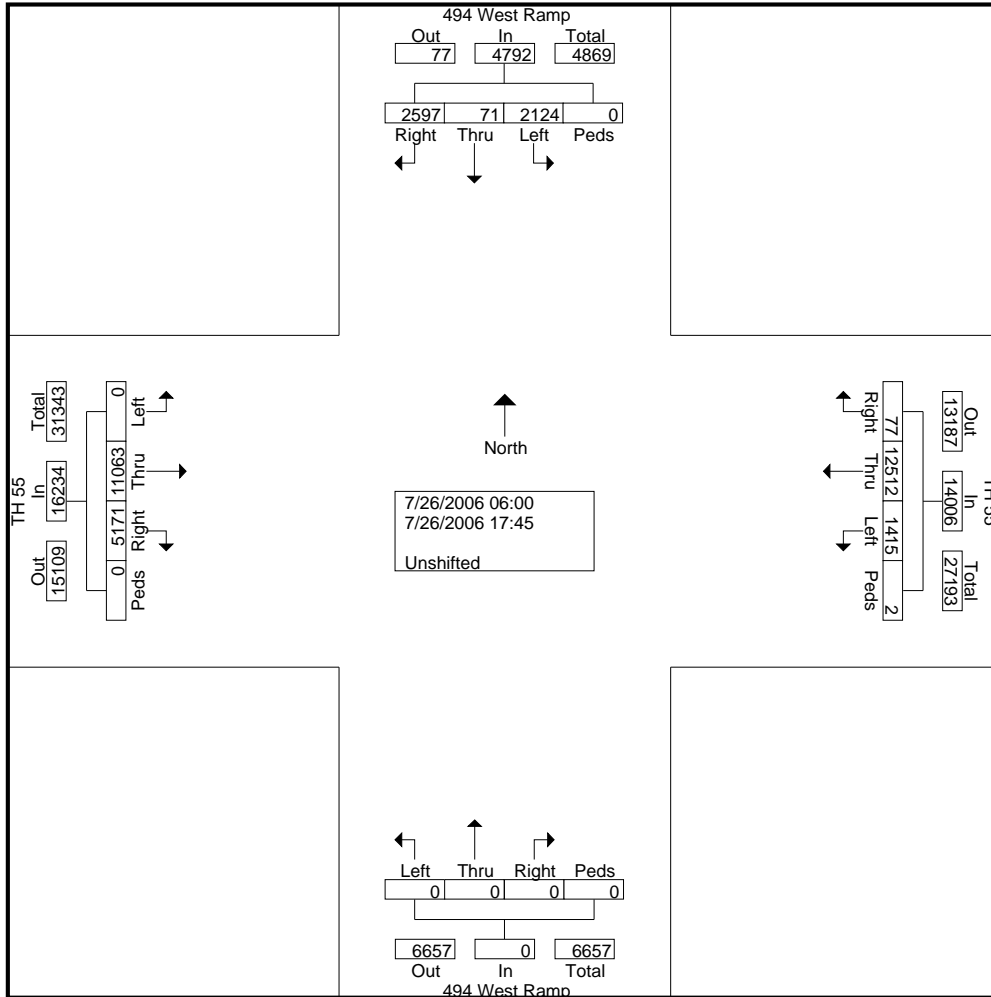



MINNESOTA DEPT OF TRANSPORTATION

TRAFFIC DATA COLLECTION - METRO

File Name : TH 55 @ I494 WEST RAMP 2006
 Site Code : 07261112
 Start Date : 7/26/2006
 Page No : 3

Start Time	494 West Ramp Southbound					TH 55 Westbound					494 West Ramp Northbound					TH 55 Eastbound					Int. Total
	Left	Thru	Right	Peds	App. Total	Left	Thru	Right	Peds	App. Total	Left	Thru	Right	Peds	App. Total	Left	Thru	Right	Peds	App. Total	
Peak Hour Analysis From 06:00 to 09:45 - Peak 1 of 1																					
Peak Hour for Entire Intersection Begins at 07:15																					
07:15	115	0	105	0	220	18	303	0	0	321	0	0	0	0	0	0	483	139	0	622	1163
07:30	149	0	104	0	253	22	325	0	0	347	0	0	0	0	0	0	508	138	0	646	1246
07:45	135	0	124	0	259	32	392	0	0	424	0	0	0	0	0	0	523	134	0	657	1340
08:00	124	0	106	0	230	22	342	0	0	364	0	0	0	0	0	0	470	165	0	635	1229
Total Volume	523	0	439	0	962	94	1362	0	0	1456	0	0	0	0	0	0	1984	576	0	2560	4978
% App. Total	54.4	0	45.6	0		6.5	93.5	0	0		0	0	0	0	0	0	77.5	22.5	0		
PHF	.878	.000	.885	.000	.929	.734	.869	.000	.000	.858	.000	.000	.000	.000	.000	.000	.948	.873	.000	.974	.929

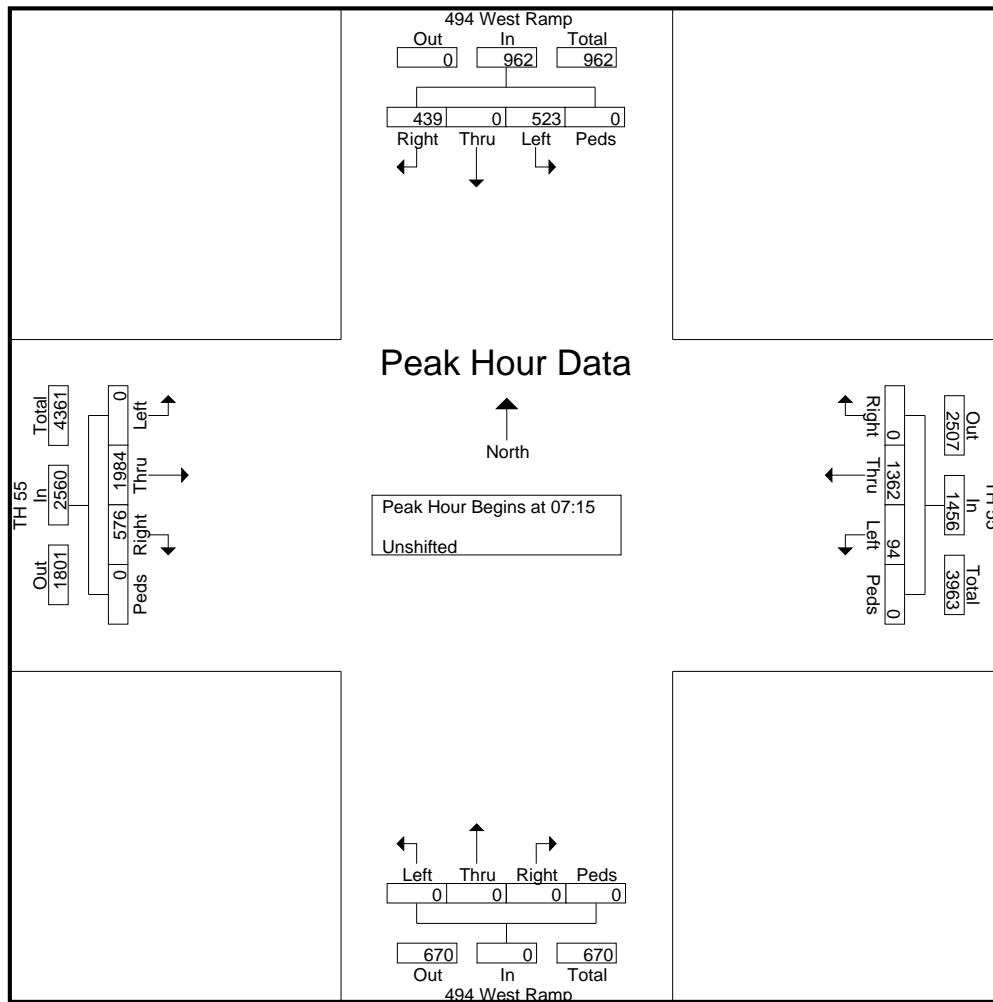



MINNESOTA DEPT OF TRANSPORTATION

TRAFFIC DATA COLLECTION - METRO

File Name : TH 55 @ I494 WEST RAMP 2006
 Site Code : 07261112
 Start Date : 7/26/2006
 Page No : 4

Start Time	494 West Ramp Southbound					TH 55 Westbound					494 West Ramp Northbound					TH 55 Eastbound					Int. Total
	Left	Thru	Right	Peds	App. Total	Left	Thru	Right	Peds	App. Total	Left	Thru	Right	Peds	App. Total	Left	Thru	Right	Peds	App. Total	
12:00	53	0	94	0	147	62	402	0	0	464	0	0	0	0	0	0	323	150	0	473	1084
12:15	50	0	89	0	139	51	422	0	0	473	0	0	0	0	0	0	330	165	0	495	1107
12:30	49	0	67	0	116	56	399	0	0	455	0	0	0	0	0	0	330	175	0	505	1076
12:45	63	0	79	0	142	49	414	0	0	463	0	0	0	0	0	0	359	182	0	541	1146
Total Volume	215	0	329	0	544	218	1637	0	0	1855	0	0	0	0	0	0	1342	672	0	2014	4413
% App. Total	39.5	0	60.5	0		11.8	88.2	0	0		0	0	0	0		0	66.6	33.4	0		
PHF	.853	.000	.875	.000	.925	.879	.970	.000	.000	.980	.000	.000	.000	.000	.000	.000	.935	.923	.000	.931	.963

Peak Hour Analysis From 10:00 to 13:45 - Peak 1 of 1
 Peak Hour for Entire Intersection Begins at 12:00

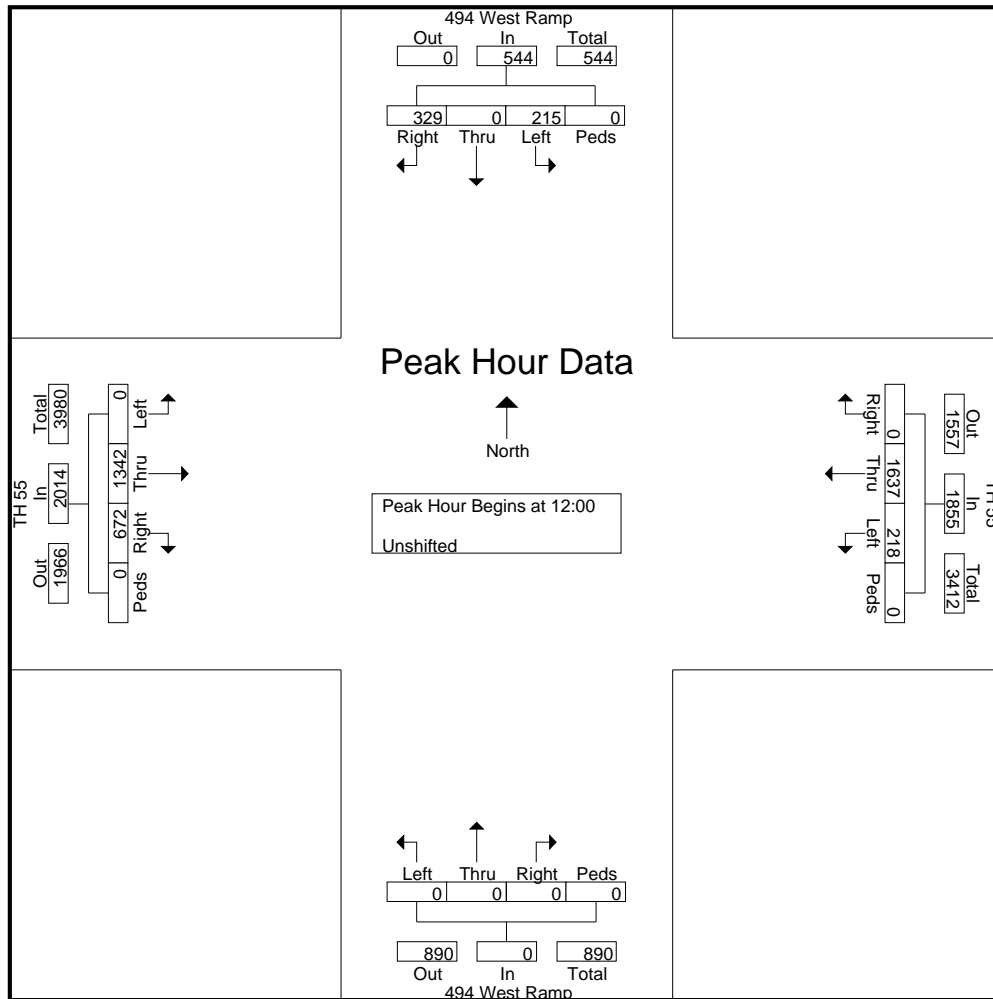



MINNESOTA DEPT OF TRANSPORTATION

TRAFFIC DATA COLLECTION - METRO

File Name : TH 55 @ I494 WEST RAMP 2006
 Site Code : 07261112
 Start Date : 7/26/2006
 Page No : 5

Start Time	494 West Ramp Southbound					TH 55 Westbound					494 West Ramp Northbound					TH 55 Eastbound					Int. Total
	Left	Thru	Right	Peds	App. Total	Left	Thru	Right	Peds	App. Total	Left	Thru	Right	Peds	App. Total	Left	Thru	Right	Peds	App. Total	
16:30	22	0	47	0	69	72	530	0	2	604	0	0	0	0	0	0	347	199	0	546	1219
16:45	36	1	55	0	92	43	574	2	0	619	0	0	0	0	0	0	297	177	0	474	1185
17:00	28	0	42	0	70	66	529	0	0	595	0	0	0	0	0	0	394	187	0	581	1246
17:15	41	1	65	0	107	71	547	0	0	618	0	0	0	0	0	0	323	155	0	478	1203
Total Volume	127	2	209	0	338	252	2180	2	2	2436	0	0	0	0	0	0	1361	718	0	2079	4853
% App. Total	37.6	0.6	61.8	0		10.3	89.5	0.1	0.1		0	0	0	0	0	0	65.5	34.5	0		
PHF	.774	.500	.804	.000	.790	.875	.949	.250	.250	.984	.000	.000	.000	.000	.000	.000	.864	.902	.000	.895	.974

Peak Hour Analysis From 14:00 to 17:45 - Peak 1 of 1
 Peak Hour for Entire Intersection Begins at 16:30

