

Short Elliott Hendrickson Inc.

3535 Vadnais Center Drive
St. Paul, MN 55110

"Building a Better World for All of Us"



TRAFFIC DATA

Th 52 & Upper 55th St E Ramp

Ref.Pt.: 125.928

Data By: Short Elliott Hendrickson, Inc.

TURN MOVEMENT COUNT

File Name : TH 52 & Upper 55th E Ramp 2019

Site Code : 3b

Start Date : 5/2/2019

Page No : 1

Groups Printed- Vehicles - Trucks

Start Time	Bishop Ave Southbound					Upper 55th St Westbound					TH 52 Northbound Ramp Northbound					Upper 55th St Eastbound					Int. Total
	Left	Thru	Right	Peds	App. Total	Left	Thru	Right	Peds	App. Total	Left	Thru	Right	Peds	App. Total	Left	Thru	Right	Peds	App. Total	
06:00	2	18	5	0	25	29	21	7	0	57	9	4	5	0	18	8	15	12	0	35	135
06:15	5	8	9	0	22	27	22	7	0	56	7	4	6	0	17	9	43	32	0	84	179
06:30	6	23	12	0	41	36	30	8	0	74	12	5	11	0	28	11	46	22	0	79	222
06:45	2	17	8	0	27	38	30	6	0	74	20	6	8	0	34	12	57	27	0	96	231
Total	15	66	34	0	115	130	103	28	0	261	48	19	30	0	97	40	161	93	0	294	767
07:00	1	16	12	0	29	48	35	11	0	94	18	8	14	0	40	11	53	23	0	87	250
07:15	4	21	6	0	31	64	31	12	0	107	31	8	15	0	54	24	56	24	0	104	296
07:30	7	14	7	0	28	56	46	12	0	114	28	8	17	0	53	11	84	32	0	127	322
07:45	6	15	15	0	36	37	41	11	0	89	49	13	25	0	87	15	69	28	0	112	324
Total	18	66	40	0	124	205	153	46	0	404	126	37	71	0	234	61	262	107	0	430	1192
08:00	6	11	7	0	24	43	42	9	0	94	37	8	20	0	65	16	84	25	0	125	308
08:15	8	17	11	0	36	41	56	11	0	108	30	9	19	0	58	14	75	31	0	120	322
08:30	11	17	15	0	43	40	31	13	0	84	17	7	20	0	44	24	96	21	0	141	312
08:45	7	11	8	1	27	45	46	14	0	105	17	1	16	0	34	26	87	18	0	131	297
Total	32	56	41	1	130	169	175	47	0	391	101	25	75	0	201	80	342	95	0	517	1239
09:00	9	15	6	0	30	46	45	17	0	108	5	7	14	2	28	14	77	20	0	111	277
09:15	5	17	7	0	29	42	38	7	0	87	11	4	17	0	32	24	73	11	0	108	256
09:30	5	9	9	1	24	40	35	11	0	86	9	6	21	0	36	22	89	12	0	123	269
09:45	1	13	11	0	25	45	36	12	0	93	13	3	16	0	32	18	101	22	0	141	291
Total	20	54	33	1	108	173	154	47	0	374	38	20	68	2	128	78	340	65	0	483	1093
10:00	6	18	9	0	33	37	34	16	0	87	9	5	13	0	27	16	82	13	0	111	258
10:15	4	13	9	0	26	36	43	13	0	92	12	8	14	0	34	30	98	19	0	147	299
10:30	2	11	18	0	31	51	38	15	0	104	7	6	6	0	19	28	78	24	0	130	284
10:45	8	14	13	0	35	43	42	12	0	97	6	10	12	0	28	25	90	19	0	134	294
Total	20	56	49	0	125	167	157	56	0	380	34	29	45	0	108	99	348	75	0	522	1135
11:00	9	9	13	0	31	43	35	19	0	97	12	14	13	0	39	41	105	23	0	169	336
11:15	8	10	14	0	32	48	40	15	0	103	10	10	12	0	32	26	108	20	0	154	321
11:30	10	19	15	0	44	39	46	10	0	95	7	8	15	0	30	45	98	24	0	167	336
11:45	8	23	17	0	48	49	53	17	0	119	12	8	11	0	31	37	152	23	0	212	410
Total	35	61	59	0	155	179	174	61	0	414	41	40	51	0	132	149	463	90	0	702	1403
12:00	14	23	13	0	50	79	48	31	0	158	6	9	23	0	38	34	108	28	0	170	416
12:15	14	13	14	0	41	66	54	13	0	133	13	12	14	0	39	43	116	12	0	171	384
12:30	14	25	12	0	51	54	54	19	0	127	8	9	15	0	32	25	102	29	1	157	367
12:45	10	19	26	6	61	57	50	15	0	122	15	7	12	0	34	36	117	25	0	178	395
Total	52	80	65	6	203	256	206	78	0	540	42	37	64	0	143	138	443	94	1	676	1562
13:00	21	22	19	0	62	44	46	12	0	102	14	10	17	0	41	27	101	32	0	160	365
13:15	13	26	19	0	58	48	50	10	0	108	10	7	14	0	31	29	105	14	0	148	345
13:30	14	18	17	0	49	50	48	6	0	104	13	5	11	0	29	25	130	18	0	173	355
13:45	13	20	22	0	55	48	46	16	0	110	11	11	13	0	35	29	140	17	0	186	386
Total	61	86	77	0	224	190	190	44	0	424	48	33	55	0	136	110	476	81	0	667	1451

Short Elliott Hendrickson Inc.

3535 Vadnais Center Drive
St. Paul, MN 55110

"Building a Better World for All of Us"



TRAFFIC DATA

Th 52 & Upper 55th St E Ramp

Ref.Pt.: 125.928

Data By: Short Elliott Hendrickson, Inc.

TURN MOVEMENT COUNT

File Name : TH 52 & Upper 55th E Ramp 2019

Site Code : 3b

Start Date : 5/2/2019

Page No : 2

Groups Printed- Vehicles - Trucks

Start Time	Bishop Ave Southbound					Upper 55th St Westbound					TH 52 Northbound Ramp Northbound					Upper 55th St Eastbound					Int. Total
	Left	Thru	Right	Peds	App. Total	Left	Thru	Right	Peds	App. Total	Left	Thru	Right	Peds	App. Total	Left	Thru	Right	Peds	App. Total	
14:00	9	19	18	0	46	47	58	14	0	119	5	4	14	0	23	26	112	20	0	158	346
14:15	8	13	11	0	32	55	49	6	0	110	14	5	11	0	30	23	129	37	0	189	361
14:30	15	42	17	0	74	65	47	9	0	121	11	4	14	0	29	22	116	28	0	166	390
14:45	7	22	12	0	41	43	61	5	0	109	16	10	17	0	43	26	126	34	0	186	379
Total	39	96	58	0	193	210	215	34	0	459	46	23	56	0	125	97	483	119	0	699	1476
15:00	9	18	12	1	40	51	54	11	2	118	22	9	11	0	42	29	138	37	0	204	404
15:15	5	17	10	1	33	47	45	13	0	105	9	10	23	0	42	24	125	26	0	175	355
15:30	8	32	18	0	58	48	65	11	0	124	9	9	16	0	34	31	133	25	0	189	405
15:45	9	20	19	0	48	58	48	21	0	127	12	13	24	0	49	41	187	21	0	249	473
Total	31	87	59	2	179	204	212	56	2	474	52	41	74	0	167	125	583	109	0	817	1637
16:00	17	19	32	0	68	45	73	19	0	137	13	15	13	0	41	49	173	68	0	290	536
16:15	8	23	18	0	49	54	57	10	0	121	14	12	25	0	51	54	189	31	0	274	495
16:30	15	25	24	0	64	58	62	13	0	133	14	20	9	0	43	32	229	64	0	325	565
16:45	7	20	25	2	54	57	71	16	0	144	19	17	12	0	48	61	225	49	0	335	581
Total	47	87	99	2	235	214	263	58	0	535	60	64	59	0	183	196	816	212	0	1224	2177
17:00	25	20	29	0	74	60	59	21	0	140	12	20	23	0	55	75	220	44	0	339	608
17:15	13	22	16	1	52	46	58	17	0	121	15	17	22	0	54	55	184	41	0	280	507
17:30	21	26	29	0	76	52	53	16	0	121	9	19	25	0	53	54	203	27	0	284	534
17:45	19	17	30	2	68	56	56	22	0	134	8	10	29	0	47	55	156	25	0	236	485
Total	78	85	104	3	270	214	226	76	0	516	44	66	99	0	209	239	763	137	0	1139	2134
18:00	15	18	24	0	57	35	54	15	0	104	15	16	19	0	50	51	125	31	0	207	418
18:15	15	17	12	1	45	31	50	21	0	102	15	13	12	0	40	35	120	22	0	177	364
18:30	15	31	19	0	65	44	46	9	0	99	9	16	18	0	43	34	105	16	0	155	362
18:45	16	19	15	2	52	32	34	7	0	73	10	13	12	0	35	34	89	19	0	142	302
Total	61	85	70	3	219	142	184	52	0	378	49	58	61	0	168	154	439	88	0	681	1446
Grand Total	509	965	788	18	2280	2453	2412	683	2	5550	729	492	808	2	2031	1566	5919	1365	1	8851	18712
Apprch %	22.3	42.3	34.6	0.8		44.2	43.5	12.3	0		35.9	24.2	39.8	0.1		17.7	66.9	15.4	0		
Total %	2.7	5.2	4.2	0.1	12.2	13.1	12.9	3.7	0	29.7	3.9	2.6	4.3	0	10.9	8.4	31.6	7.3	0	47.3	
Vehicles	502	947	777	14	2240	2300	2338				91.8	98.6	95.3	0	94.7	1548	5710	1336			18070
% Vehicles	98.6	98.1	98.6	77.8	98.2	93.8	96.9	98.4	100	95.7	91.8	98.6	95.3	0	94.7	98.9	96.5	97.9	0	97.1	96.6
Trucks	7	18	11	4	40	153	74	11	0	238	60	7	38	2	107	18	209	29	1	257	642
% Trucks	1.4	1.9	1.4	22.2	1.8	6.2	3.1	1.6	0	4.3	8.2	1.4	4.7	100	5.3	1.1	3.5	2.1	100	2.9	3.4

Short Elliott Hendrickson Inc.

3535 Vadnais Center Drive
St. Paul, MN 55110

"Building a Better World for All of Us"



TRAFFIC DATA

Th 52 & Upper 55th St E Ramp

Ref.Pt.: 125.928

Data By: Short Elliott Hendrickson, Inc.

TURN MOVEMENT COUNT

File Name : TH 52 & Upper 55th E Ramp 2019

Site Code : 3b

Start Date : 5/2/2019

Page No : 3

Start Time	Bishop Ave Southbound					Upper 55th St Westbound					TH 52 Northbound Ramp Northbound					Upper 55th St Eastbound					Int. Total
	Left	Thru	Right	Peds	App. Total	Left	Thru	Right	Peds	App. Total	Left	Thru	Right	Peds	App. Total	Left	Thru	Right	Peds	App. Total	
Peak Hour Analysis From 06:00 to 08:45 - Peak 1 of 1																					
Peak Hour for Entire Intersection Begins at 07:30																					
07:30	7	14	7	0	28	56	46	12	0	114	28	8	17	0	53	11	84	32	0	127	322
07:45	6	15	15	0	36	37	41	11	0	89	49	13	25	0	87	15	69	28	0	112	324
08:00	6	11	7	0	24	43	42	9	0	94	37	8	20	0	65	16	84	25	0	125	308
08:15	8	17	11	0	36	41	56	11	0	108	30	9	19	0	58	14	75	31	0	120	322
Total Volume	27	57	40	0	124	177	185	43	0	405	144	38	81	0	263	56	312	116	0	484	1276
% App. Total	21.8	46	32.3	0		43.7	45.7	10.6	0		54.8	14.4	30.8	0		11.6	64.5	24	0		
PHF	.844	.838	.667	.000	.861	.790	.826	.896	.000	.888	.735	.731	.810	.000	.756	.875	.929	.906	.000	.953	.985

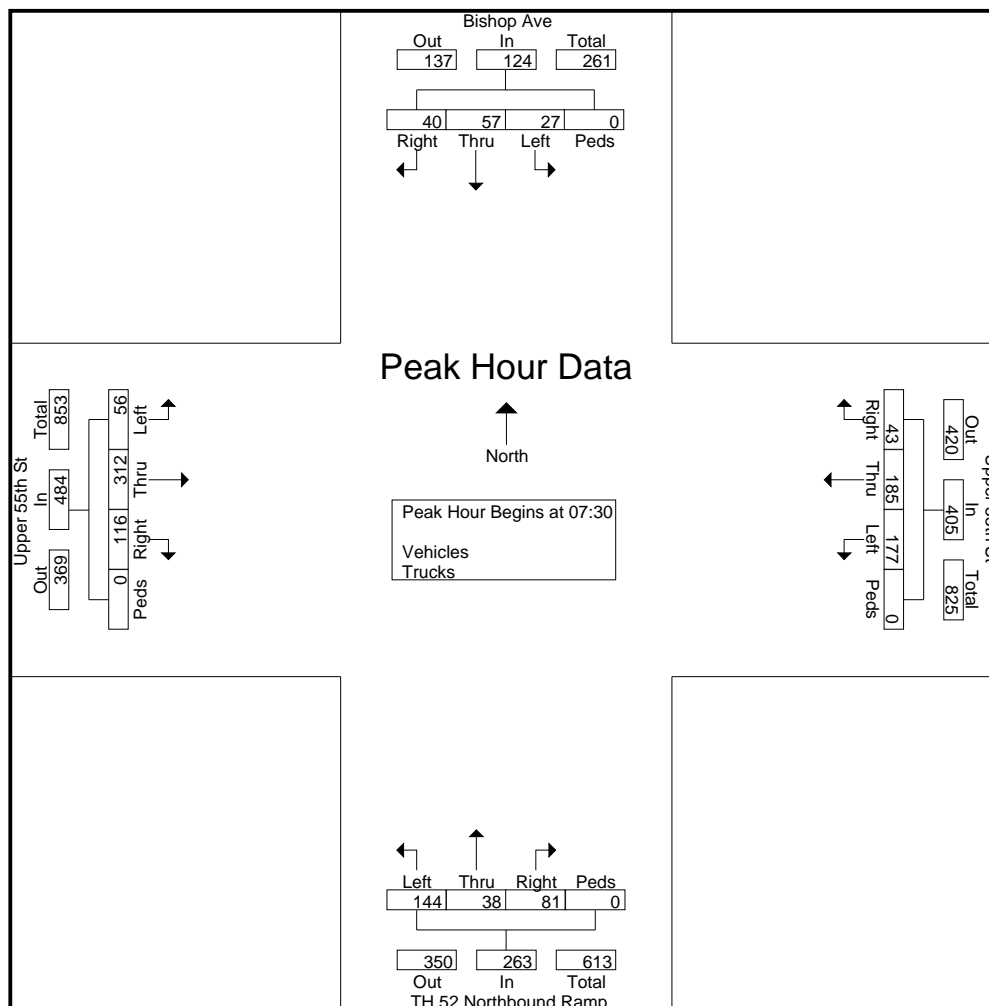

Short Elliott Hendrickson Inc.

3535 Vadnais Center Drive
St. Paul, MN 55110

"Building a Better World for All of Us"



TRAFFIC DATA

Th 52 & Upper 55th St E Ramp

Ref.Pt.: 125.928

Data By: Short Elliott Hendrickson, Inc.

TURN MOVEMENT COUNT

File Name : TH 52 & Upper 55th E Ramp 2019

Site Code : 3b

Start Date : 5/2/2019

Page No : 4

Start Time	Bishop Ave Southbound					Upper 55th St Westbound					TH 52 Northbound Ramp Northbound					Upper 55th St Eastbound					Int. Total
	Left	Thru	Right	Peds	App. Total	Left	Thru	Right	Peds	App. Total	Left	Thru	Right	Peds	App. Total	Left	Thru	Right	Peds	App. Total	
Peak Hour Analysis From 11:00 to 12:45 - Peak 1 of 1																					
Peak Hour for Entire Intersection Begins at 11:45																					
11:45	8	23	17	0	48	49	53	17	0	119	12	8	11	0	31	37	152	23	0	212	410
12:00	14	23	13	0	50	79	48	31	0	158	6	9	23	0	38	34	108	28	0	170	416
12:15	14	13	14	0	41	66	54	13	0	133	13	12	14	0	39	43	116	12	0	171	384
12:30	14	25	12	0	51	54	54	19	0	127	8	9	15	0	32	25	102	29	1	157	367
Total Volume	50	84	56	0	190	248	209	80	0	537	39	38	63	0	140	139	478	92	1	710	1577
% App. Total	26.3	44.2	29.5	0		46.2	38.9	14.9	0		27.9	27.1	45	0		19.6	67.3	13	0.1		
PHF	.893	.840	.824	.000	.931	.785	.968	.645	.000	.850	.750	.792	.685	.000	.897	.808	.786	.793	.250	.837	.948

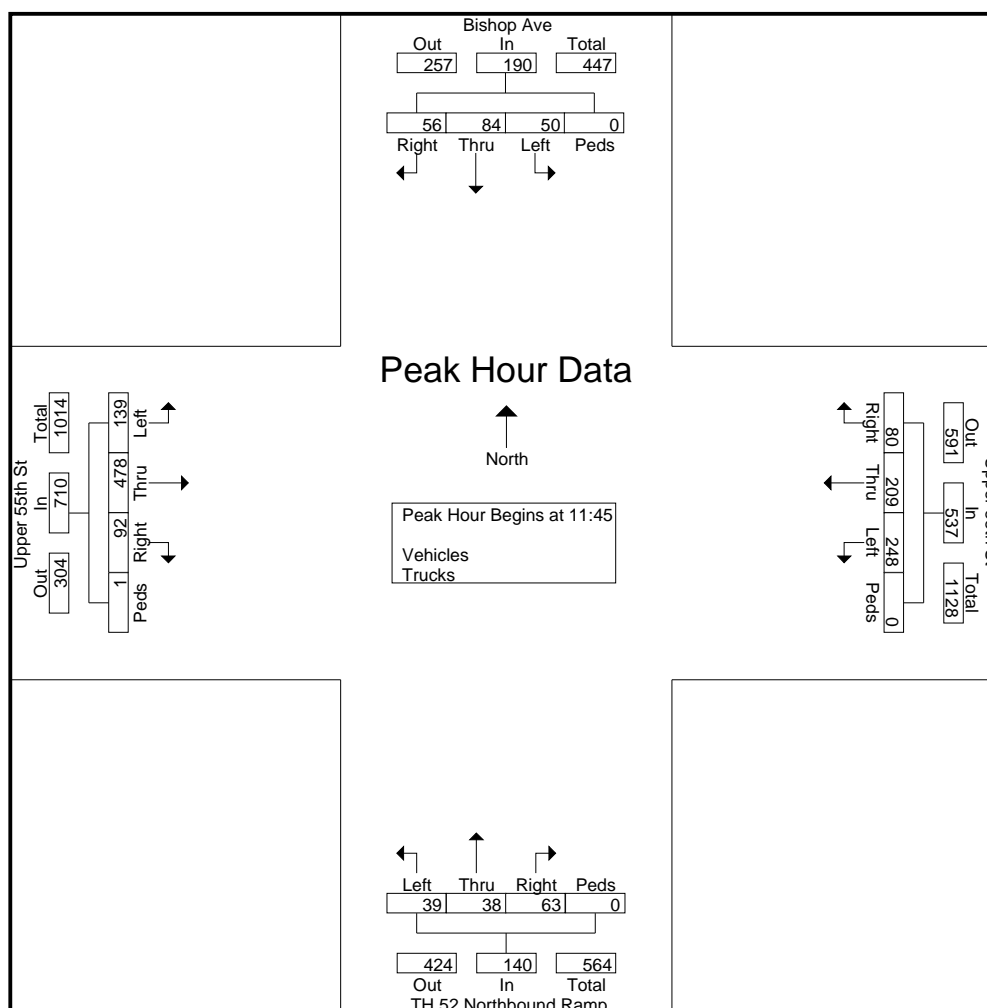

Short Elliott Hendrickson Inc.

3535 Vadnais Center Drive
St. Paul, MN 55110

"Building a Better World for All of Us"



TRAFFIC DATA

Th 52 & Upper 55th St E Ramp

Ref.Pt.: 125.928

Data By: Short Elliott Hendrickson, Inc.

TURN MOVEMENT COUNT

File Name : TH 52 & Upper 55th E Ramp 2019

Site Code : 3b

Start Date : 5/2/2019

Page No : 5

Start Time	Bishop Ave Southbound					Upper 55th St Westbound					TH 52 Northbound Ramp Northbound					Upper 55th St Eastbound					Int. Total
	Left	Thru	Right	Peds	App. Total	Left	Thru	Right	Peds	App. Total	Left	Thru	Right	Peds	App. Total	Left	Thru	Right	Peds	App. Total	
Peak Hour Analysis From 15:00 to 17:45 - Peak 1 of 1																					
Peak Hour for Entire Intersection Begins at 16:30																					
16:30	15	25	24	0	64	58	62	13	0	133	14	20	9	0	43	32	229	64	0	325	565
16:45	7	20	25	2	54	57	71	16	0	144	19	17	12	0	48	61	225	49	0	335	581
17:00	25	20	29	0	74	60	59	21	0	140	12	20	23	0	55	75	220	44	0	339	608
17:15	13	22	16	1	52	46	58	17	0	121	15	17	22	0	54	55	184	41	0	280	507
Total Volume	60	87	94	3	244	221	250	67	0	538	60	74	66	0	200	223	858	198	0	1279	2261
% App. Total	24.6	35.7	38.5	1.2		41.1	46.5	12.5	0		30	37	33	0		17.4	67.1	15.5	0		
PHF	.600	.870	.810	.375	.824	.921	.880	.798	.000	.934	.789	.925	.717	.000	.909	.743	.937	.773	.000	.943	.930

