



**MINNESOTA DEPT OF TRANSPORTATION**  
TRAFFIC DATA COLLECTION - METRO

TH-51 / SNELLING AVE AT LARPEN TEUR AVE, TH-51 SNELLING AVE AT LARPEN TEUR AVE 2007  
 REF.PT.: 006.355 Site Code : 00198733  
 DATA COLLECTED BY TDI Start Date : 5/22/2007  
 TURN MOVEMENT COUNT Page No : 1

**Groups Printed- Unshifted**

Start Time	MN-51 / SNELLING AVE. Southbound				LARPEN TEUR AVE. Westbound				MN-51 / SNELLING AVE. Northbound				LARPEN TEUR AVE. Eastbound				Int. Total
	Left	Thru	Right	Peds	Left	Thru	Right	Peds	Left	Thru	Right	Peds	Left	Thru	Right	Peds	
06:00	3	96	6	1	10	41	4	0	10	66	8	2	3	12	22	3	287
06:15	3	144	9	5	23	48	7	1	18	73	8	1	6	10	24	2	382
06:30	5	182	15	0	34	106	10	0	20	112	5	1	8	16	29	0	543
06:45	10	223	21	4	43	99	13	0	32	111	12	1	10	19	28	1	627
Total	21	645	51	10	110	294	34	1	80	362	33	5	27	57	103	6	1839
07:00	7	228	15	1	36	122	16	2	30	150	12	1	5	24	29	1	679
07:15	8	298	33	1	58	140	13	4	27	178	15	4	12	28	27	1	847
07:30	9	277	25	4	50	209	22	1	57	226	19	2	11	40	36	1	989
07:45	10	301	26	1	60	235	28	1	49	237	18	2	14	38	55	0	1075
Total	34	1104	99	7	204	706	79	8	163	791	64	9	42	130	147	3	3590
08:00	24	289	37	2	46	185	11	0	48	160	17	1	8	44	56	1	929
08:15	11	262	23	1	41	185	19	1	59	213	12	3	9	52	41	0	932
08:30	10	278	21	2	32	137	11	0	55	206	22	2	14	36	45	0	871
08:45	20	232	15	2	37	121	27	0	49	166	23	2	14	44	55	0	807
Total	65	1061	96	7	156	628	68	1	211	745	74	8	45	176	197	1	3539
*** BREAK ***																	
11:00	15	183	16	6	26	65	18	1	24	222	35	0	15	47	31	7	711
11:15	24	177	11	3	35	55	36	1	35	214	28	1	33	76	34	1	764
11:30	26	184	11	1	22	50	26	2	21	274	40	3	37	57	30	0	784
11:45	29	211	14	1	43	71	47	0	30	255	33	0	35	80	44	1	894
Total	94	755	52	11	126	241	127	4	110	965	136	4	120	260	139	9	3153
12:00	24	212	17	3	31	64	35	6	26	273	46	10	31	73	40	1	892
12:15	23	198	11	0	34	81	41	0	39	253	34	0	38	67	43	0	862
12:30	41	231	6	0	30	63	35	4	37	252	32	4	30	57	40	0	862
12:45	21	228	23	1	49	92	48	1	40	227	22	2	30	79	57	0	920
Total	109	869	57	4	144	300	159	11	142	1005	134	16	129	276	180	1	3536
*** BREAK ***																	
15:00	21	212	12	0	30	74	21	2	38	300	37	3	32	96	38	0	916
15:15	17	231	18	2	25	70	32	0	27	313	47	3	31	115	51	3	985
15:30	39	180	19	3	38	69	28	2	33	337	50	3	31	134	42	1	1009
15:45	32	210	13	6	31	84	29	5	38	381	52	2	28	124	35	2	1072
Total	109	833	62	11	124	297	110	9	136	1331	186	11	122	469	166	6	3982
16:00	41	226	14	3	17	62	20	1	49	348	43	5	30	152	53	2	1066
16:15	26	204	8	2	30	75	33	6	41	358	66	7	36	164	61	1	1118
16:30	41	222	7	0	22	53	27	0	53	362	54	3	47	183	52	1	1127
16:45	42	247	14	9	38	85	33	12	50	371	43	4	52	192	45	7	1244
Total	150	899	43	14	107	275	113	19	193	1439	206	19	165	691	211	11	4555
17:00	47	213	16	1	29	81	42	4	47	382	51	4	37	211	40	0	1205
17:15	39	289	18	0	35	69	44	1	46	380	60	4	37	182	44	4	1252
17:30	57	254	10	7	30	75	47	0	36	291	48	1	27	218	44	2	1147
17:45	39	253	11	3	30	72	29	5	35	313	52	3	40	170	36	3	1094
Total	182	1009	55	11	124	297	162	10	164	1366	211	12	141	781	164	9	4698



**MINNESOTA DEPT OF TRANSPORTATION**  
 TRAFFIC DATA COLLECTION - METRO

TH-51 / SNELLING AVE AT LARPEN TEUR AVE, TH-51 SNELLING AVE AT LARPEN TEUR AVE 2007  
 REF.PT.: 006.355 Site Code : 00198733  
 DATA COLLECTED BY TDI Start Date : 5/22/2007  
 TURN MOVEMENT COUNT Page No : 2

**Groups Printed- Unshifted**

	MN-51 / SNELLING AVE.				LARPEN TEUR AVE.				MN-51 / SNELLING AVE.				LARPEN TEUR AVE.				Int. Total
	Southbound				Westbound				Northbound				Eastbound				
	Left	Thru	Right	Peds	Left	Thru	Right	Peds	Left	Thru	Right	Peds	Left	Thru	Right	Peds	
Grand Total	764	7175	515	75	1095	3038	852	63	1199	8004	1044	84	791	2840	1307	46	28892
Apprch %	9	84.1	6	0.9	21.7	60.2	16.9	1.2	11.6	77.5	10.1	0.8	15.9	57	26.2	0.9	
Total %	2.6	24.8	1.8	0.3	3.8	10.5	2.9	0.2	4.1	27.7	3.6	0.3	2.7	9.8	4.5	0.2	



# MINNESOTA DEPT OF TRANSPORTATION

## TRAFFIC DATA COLLECTION - METRO

TH-51 / SNELLING AVE AT LARPEN TEUR AVE, TH-51 SNELLING AVE AT LARPEN TEUR AVE 2007  
 REF.PT.: 006.355 Site Code : 00198733  
 DATA COLLECTED BY TDI Start Date : 5/22/2007  
 TURN MOVEMENT COUNT Page No : 3

Start Time	MN-51 / SNELLING AVE. Southbound					LARPEN TEUR AVE. Westbound					MN-51 / SNELLING AVE. Northbound					LARPEN TEUR AVE. Eastbound					Int. Total
	Left	Thru	Right	Peds	App. Total	Left	Thru	Right	Peds	App. Total	Left	Thru	Right	Peds	App. Total	Left	Thru	Right	Peds	App. Total	
Peak Hour Analysis From 06:00 to 08:45 - Peak 1 of 1																					
Peak Hour for Entire Intersection Begins at 07:30																					
07:30	9	277	25	4	315	50	209	22	1	282	57	226	19	2	304	11	40	36	1	88	989
07:45	10	301	26	1	338	60	235	28	1	324	49	237	18	2	306	14	38	55	0	107	1075
08:00	24	289	37	2	352	46	185	11	0	242	48	160	17	1	226	8	44	56	1	109	929
08:15	11	262	23	1	297	41	185	19	1	246	59	213	12	3	287	9	52	41	0	102	932
Total Volume	54	1129	111	8	1302	197	814	80	3	1094	213	836	66	8	1123	42	174	188	2	406	3925
% App. Total	4.1	86.7	8.5	0.6		18	74.4	7.3	0.3		19	74.4	5.9	0.7		10.3	42.9	46.3	0.5		
PHF	.563	.938	.750	.500	.925	.821	.866	.714	.750	.844	.903	.882	.868	.667	.917	.750	.837	.839	.500	.931	.913

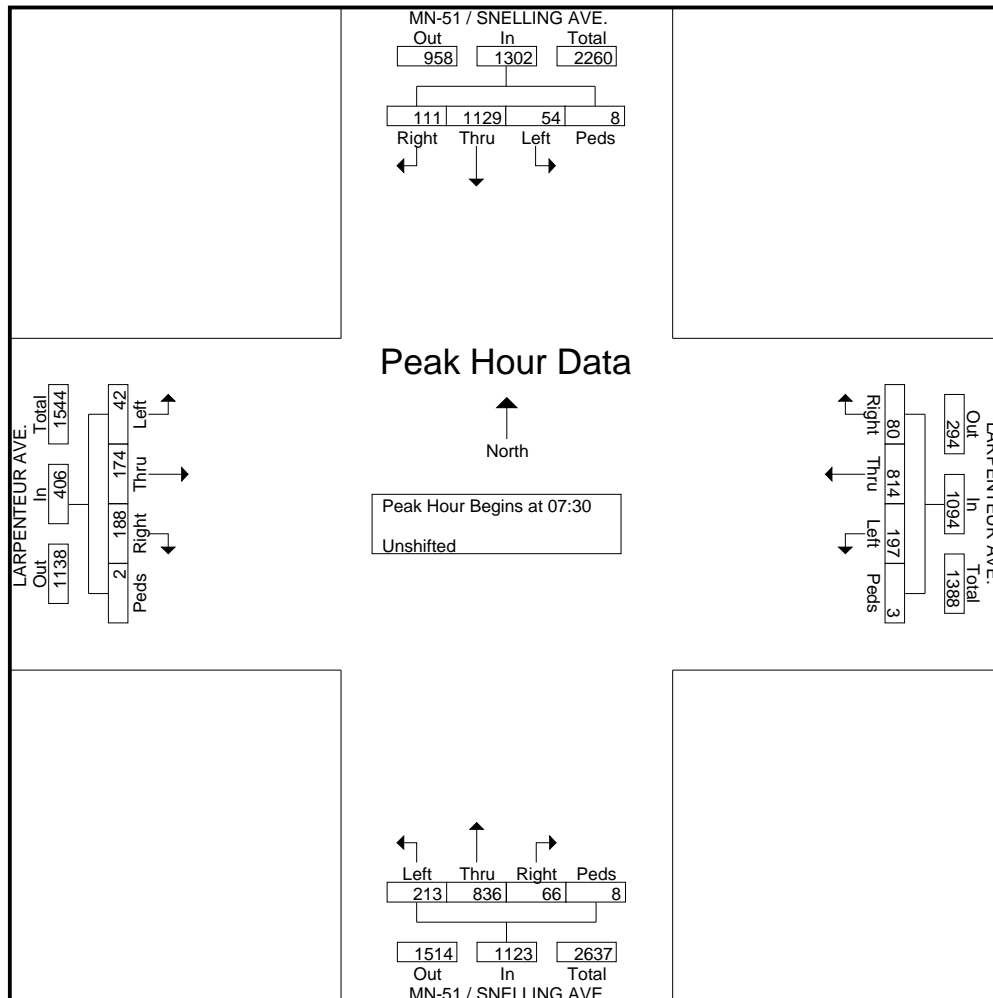



# MINNESOTA DEPT OF TRANSPORTATION

## TRAFFIC DATA COLLECTION - METRO

TH-51 / SNELLING AVE AT LARPEN TEUR AVE, TH-51 SNELLING AVE AT LARPEN TEUR AVE 2007  
 REF.PT.: 006.355 Site Code : 00198733  
 DATA COLLECTED BY TDI Start Date : 5/22/2007  
 TURN MOVEMENT COUNT Page No : 4

Start Time	MN-51 / SNELLING AVE. Southbound					LARPEN TEUR AVE. Westbound					MN-51 / SNELLING AVE. Northbound					LARPEN TEUR AVE. Eastbound					Int. Total
	Left	Thru	Right	Peds	App. Total	Left	Thru	Right	Peds	App. Total	Left	Thru	Right	Peds	App. Total	Left	Thru	Right	Peds	App. Total	
Peak Hour Analysis From 15:00 to 17:45 - Peak 1 of 1																					
Peak Hour for Entire Intersection Begins at 16:45																					
16:45	42	247	14	9	312	38	85	33	12	168	50	371	43	4	468	52	192	45	7	296	1244
17:00	47	213	16	1	277	29	81	42	4	156	47	382	51	4	484	37	211	40	0	288	1205
17:15	39	289	18	0	346	35	69	44	1	149	46	380	60	4	490	37	182	44	4	267	1252
17:30	57	254	10	7	328	30	75	47	0	152	36	291	48	1	376	27	218	44	2	291	1147
Total Volume	185	1003	58	17	1263	132	310	166	17	625	179	1424	202	13	1818	153	803	173	13	1142	4848
% App. Total	14.6	79.4	4.6	1.3		21.1	49.6	26.6	2.7		9.8	78.3	11.1	0.7		13.4	70.3	15.1	1.1		
PHF	.811	.868	.806	.472	.913	.868	.912	.883	.354	.930	.895	.932	.842	.813	.928	.736	.921	.961	.464	.965	.968

