

SEH CONSULTING
Traffic Data Collection
TURN MOVEMENT COUNT

TH 51 (Snelling Ave) at Hoyt Avenue W
Ref.Pt.: 006.105
data by SEH
TURN MOVEMENT COUNT

File Name : TH-51 at Hoyt Ave 2008
Site Code : 00000015
Start Date : 12/2/2008
Page No : 1

Groups Printed- Unshifted - Heavy Veh

Start Time	TH-51 / Snelling Ave. Southbound				Hoyt Ave W Westbound				TH-51 / Snelling Ave. Northbound				Hoyt Ave W Eastbound				Int. Total	
	Left	Thru	Right	Peds	Left	Thru	Right	Peds	Left	Thru	Right	Peds	Left	Thru	Right	Peds		
06:00	0	126	1	0	3	1	2	1	0	85	0	0	0	0	0	0	0	219
06:15	0	186	1	0	5	0	4	0	2	79	0	0	1	1	0	0	0	279
06:30	1	228	1	0	12	3	2	0	2	90	0	0	3	0	1	0	0	343
06:45	0	311	0	0	12	0	8	0	2	141	1	0	0	0	1	0	0	476
Total	1	851	3	0	32	4	16	1	6	395	1	0	4	1	2	0	0	1317
07:00	4	327	0	0	6	0	3	0	0	156	3	0	0	1	0	0	0	500
07:15	1	401	1	0	22	1	11	0	0	187	1	0	1	0	1	0	0	627
07:30	3	513	2	0	22	0	4	1	0	265	2	1	0	0	0	0	0	813
07:45	4	487	0	0	31	0	5	0	1	265	6	2	0	1	0	0	0	802
Total	12	1728	3	0	81	1	23	1	1	873	12	3	1	2	1	0	0	2742
08:00	5	421	0	2	17	0	11	0	4	267	7	1	1	0	0	0	0	736
08:15	3	403	4	2	19	0	10	0	3	251	4	4	0	0	0	0	0	703
08:30	0	394	0	0	16	0	9	0	2	252	2	0	1	0	1	0	0	677
08:45	2	369	0	0	11	2	2	0	1	248	4	0	0	0	2	0	0	641
Total	10	1587	4	4	63	2	32	0	10	1018	17	5	2	0	3	0	0	2757
*** BREAK ***																		
11:00	4	191	0	0	4	0	4	0	1	246	2	0	3	0	3	0	0	458
11:15	5	252	1	0	7	1	5	0	1	249	2	0	1	1	3	0	0	528
11:30	6	261	0	0	6	0	4	0	2	304	4	0	2	0	3	0	0	592
11:45	8	292	0	0	5	0	5	0	2	338	5	0	3	0	3	0	0	661
Total	23	996	1	0	22	1	18	0	6	1137	13	0	9	1	12	0	0	2239
12:00	7	285	1	0	4	1	3	0	2	338	7	0	0	0	0	0	0	648
12:15	5	285	0	0	3	1	3	1	0	322	10	0	1	0	0	0	0	631
12:30	2	303	1	2	6	1	5	2	1	296	8	0	1	0	2	0	0	630
12:45	6	299	1	0	9	0	3	0	0	260	8	1	0	1	1	0	0	589
Total	20	1172	3	2	22	3	14	3	3	1216	33	1	2	1	3	0	0	2498
*** BREAK ***																		
15:00	2	274	1	1	5	0	5	2	0	409	11	2	5	1	3	2	0	723
15:15	4	308	0	2	9	0	7	2	2	382	5	1	1	0	1	1	0	725
15:30	1	299	1	0	4	1	5	0	0	465	18	5	1	0	0	2	0	802
15:45	1	331	1	1	1	0	4	2	1	436	16	9	2	0	3	2	0	810
Total	8	1212	3	4	19	1	21	6	3	1692	50	17	9	1	7	7	0	3060
16:00	4	290	0	2	6	2	3	0	1	518	18	5	1	1	1	4	0	856
16:15	2	310	1	0	5	0	5	0	0	460	20	2	1	0	1	0	0	807
16:30	5	347	2	3	4	0	6	0	1	534	23	2	1	0	2	0	0	930
16:45	6	303	0	0	5	0	1	0	3	520	31	0	1	1	1	0	0	872
Total	17	1250	3	5	20	2	15	0	5	2032	92	9	4	2	5	4	0	3465
17:00	3	354	0	0	9	0	2	1	1	504	28	1	0	0	3	3	0	909
17:15	6	346	2	0	10	0	1	0	1	458	20	1	1	1	4	0	0	851
17:30	11	356	0	1	3	0	4	0	0	446	13	2	0	0	4	0	0	840
17:45	10	313	0	0	10	0	5	0	1	347	16	0	1	0	4	0	0	707
Total	30	1369	2	1	32	0	12	1	3	1755	77	4	2	1	15	3	0	3307
Grand Total	121	10165	22	16	291	14	151	12	37	10118	295	39	33	9	48	14	0	21385
Apprch %	1.2	98.5	0.2	0.2	62.2	3	32.3	2.6	0.4	96.5	2.8	0.4	31.7	8.7	46.2	13.5	0	
Total %	0.6	47.5	0.1	0.1	1.4	0.1	0.7	0.1	0.2	47.3	1.4	0.2	0.2	0	0.2	0.1	0	
Unshifted	121	9963	21	16	285	14	146	12	37	9927	292	39	33	9	47	14	0	20976
% Unshifted	100	98	95.5	100	97.9	100	96.7	100	100	98.1	99	100	100	100	97.9	100	0	98.1
Heavy Veh	0	202	1	0	6	0	5	0	0	191	3	0	0	0	1	0	0	409
% Heavy Veh	0	2	4.5	0	2.1	0	3.3	0	0	1.9	1	0	0	0	2.1	0	0	1.9

SEH CONSULTING
Traffic Data Collection
TURN MOVEMENT COUNT

TH 51 (Snelling Ave) at Hoyt Avenue W
Ref.Pt.: 006.105
data by SEH
TURN MOVEMENT COUNT

File Name : TH-51 at Hoyt Ave 2008
Site Code : 00000015
Start Date : 12/2/2008
Page No : 2

Start Time	TH-51 / Snelling Ave. Southbound					Hoyt Ave W Westbound					TH-51 / Snelling Ave. Northbound					Hoyt Ave W Eastbound					Int. Total
	Left	Thru	Right	Peds	App. Total	Left	Thru	Right	Peds	App. Total	Left	Thru	Right	Peds	App. Total	Left	Thru	Right	Peds	App. Total	
Peak Hour Analysis From 06:00 to 08:45 - Peak 1 of 1																					
Peak Hour for Entire Intersection Begins at 07:30																					
07:30	3	513	2	0	518	22	0	4	1	27	0	265	2	1	268	0	0	0	0	0	813
07:45	4	487	0	0	491	31	0	5	0	36	1	265	6	2	274	0	1	0	0	1	802
08:00	5	421	0	2	428	17	0	11	0	28	4	267	7	1	279	1	0	0	0	1	736
08:15	3	403	4	2	412	19	0	10	0	29	3	251	4	4	262	0	0	0	0	0	703
Total Volume	15	1824	6	4	1849	89	0	30	1	120	8	1048	19	8	1083	1	1	0	0	2	3054
% App. Total	0.8	98.6	0.3	0.2		74.2	0	25	0.8		0.7	96.8	1.8	0.7		50	50	0	0		
PHF	.750	.889	.375	.500	.892	.718	.000	.682	.250	.833	.500	.981	.679	.500	.970	.250	.250	.000	.000	.500	.939

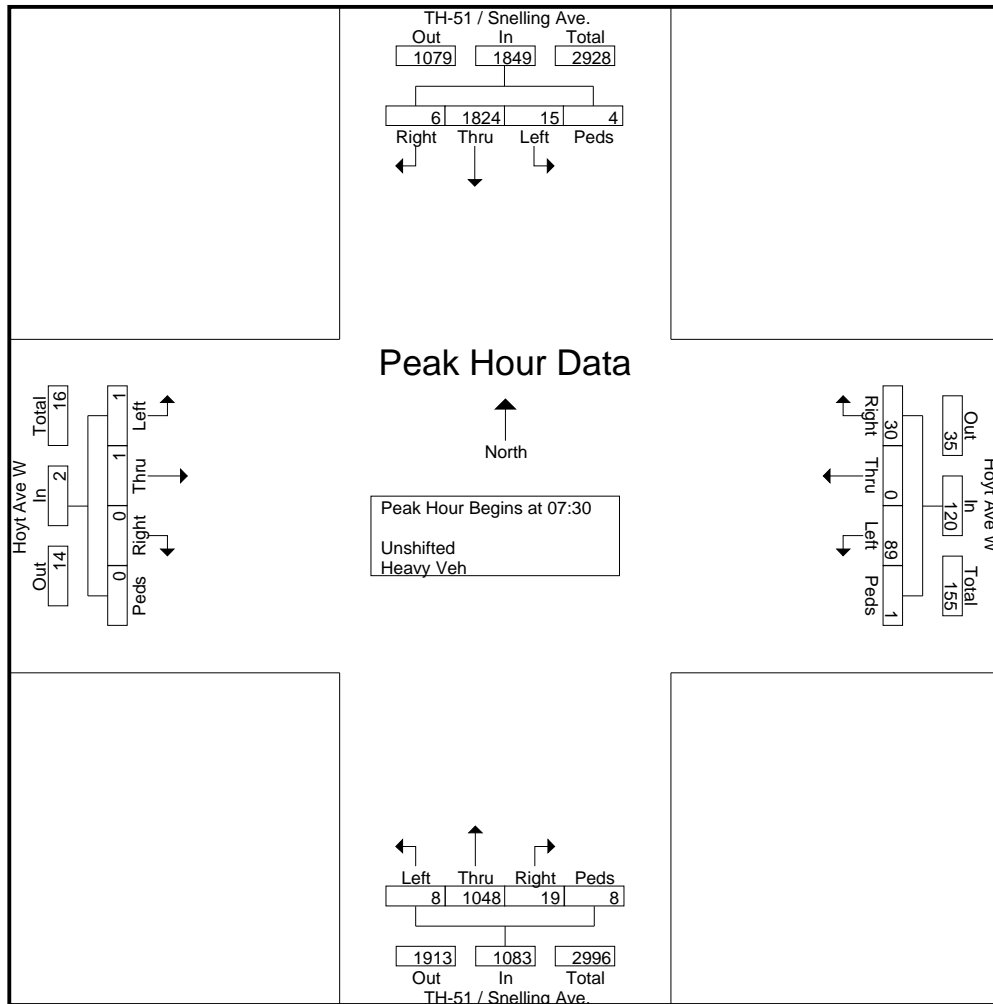

SEH CONSULTING
Traffic Data Collection
TURN MOVEMENT COUNT

TH 51 (Snelling Ave) at Hoyt Avenue W
Ref.Pt.: 006.105
data by SEH
TURN MOVEMENT COUNT

File Name : TH-51 at Hoyt Ave 2008
Site Code : 00000015
Start Date : 12/2/2008
Page No : 3

Start Time	TH-51 / Snelling Ave. Southbound					Hoyt Ave W Westbound					TH-51 / Snelling Ave. Northbound					Hoyt Ave W Eastbound					Int. Total
	Left	Thru	Right	Peds	App. Total	Left	Thru	Right	Peds	App. Total	Left	Thru	Right	Peds	App. Total	Left	Thru	Right	Peds	App. Total	
Peak Hour Analysis From 15:00 to 17:45 - Peak 1 of 1																					
Peak Hour for Entire Intersection Begins at 16:30																					
16:30	5	347	2	3	357	4	0	6	0	10	1	534	23	2	560	1	0	2	0	3	930
16:45	6	303	0	0	309	5	0	1	0	6	3	520	31	0	554	1	1	1	0	3	872
17:00	3	354	0	0	357	9	0	2	1	12	1	504	28	1	534	0	0	3	3	6	909
17:15	6	346	2	0	354	10	0	1	0	11	1	458	20	1	480	1	1	4	0	6	851
Total Volume	20	1350	4	3	1377	28	0	10	1	39	6	2016	102	4	2128	3	2	10	3	18	3562
% App. Total	1.5	98	0.3	0.2		71.8	0	25.6	2.6		0.3	94.7	4.8	0.2		16.7	11.1	55.6	16.7		
PHF	.833	.953	.500	.250	.964	.700	.000	.417	.250	.813	.500	.944	.823	.500	.950	.750	.500	.625	.250	.750	.958

