



MINNESOTA DEPT OF TRANSPORTATION

TRAFFIC DATA COLLECTION - METRO

TH-5 at TH-36 , south ramps STILLWATER

File Name : TH-5 at TH-36 south ramps 2010

Ref.Pt.: 201.189

Site Code : 00000000

JAMAR # T-2638 CAH

Start Date : 12/2/2010

TURN MOVEMENT COUNT

Page No : 1

Groups Printed- Cars & Trucks

Start Time	TH-5 Southbound				ramp to EB TH-36 Westbound				TH-5 Northbound				ramp from EB TH-36 Eastbound				Int. Total
	Left	Thru	Right	Peds	Left	Thru	Right	Peds	Left	Thru	Right	Peds	Left	Thru	Right	Peds	
06:00	6	48	0	0	0	0	0	0	0	20	6	0	10	0	13	0	103
06:15	5	69	0	0	0	0	0	0	0	32	15	0	10	0	21	0	152
06:30	8	86	0	0	0	0	0	0	0	41	16	0	16	0	23	0	190
06:45	6	94	0	0	0	0	0	0	0	45	15	0	18	1	42	1	222
Total	25	297	0	0	0	0	0	0	0	138	52	0	54	1	99	1	667
07:00	8	103	0	0	0	0	0	0	0	64	24	0	32	0	45	0	276
07:15	8	132	0	0	0	0	0	0	0	83	23	0	21	0	45	0	312
07:30	14	137	0	0	0	0	0	0	0	103	30	0	38	0	49	0	371
07:45	17	115	0	0	0	0	0	0	1	94	43	0	46	0	61	0	377
Total	47	487	0	0	0	0	0	0	1	344	120	0	137	0	200	0	1336
08:00	8	103	0	0	0	0	0	0	0	70	38	0	44	0	36	0	299
08:15	11	111	0	0	0	0	0	0	0	94	37	0	37	0	39	0	329
08:30	7	114	0	0	0	0	0	0	0	101	45	0	45	0	48	0	360
08:45	25	98	0	0	0	0	0	0	0	123	45	0	50	0	54	0	395
Total	51	426	0	0	0	0	0	0	0	388	165	0	176	0	177	0	1383
*** BREAK ***																	
15:00	15	132	0	0	0	0	0	0	1	169	41	2	59	0	54	0	473
15:15	17	141	0	0	0	0	0	0	0	198	61	0	75	0	62	0	554
15:30	13	142	0	0	0	0	0	0	0	193	58	1	86	0	47	0	540
15:45	23	121	0	0	0	0	0	0	0	178	62	1	86	0	61	0	532
Total	68	536	0	0	0	0	0	0	1	738	222	4	306	0	224	0	2099
16:00	32	134	0	0	0	0	0	0	0	195	78	1	65	0	73	0	578
16:15	21	130	0	0	0	0	0	0	0	182	74	0	83	1	47	0	538
16:30	15	149	0	0	0	0	0	0	0	198	53	0	85	0	55	0	555
16:45	18	179	0	0	0	0	0	0	0	227	62	0	104	0	64	0	654
Total	86	592	0	0	0	0	0	0	0	802	267	1	337	1	239	0	2325
17:00	26	157	0	0	0	0	0	0	0	212	54	0	92	0	70	0	611
17:15	17	145	0	0	0	0	0	0	0	215	55	0	87	1	67	0	587
17:30	15	121	0	0	0	0	0	0	0	187	54	0	90	0	58	0	525
17:45	11	115	0	0	0	0	0	0	0	186	60	0	102	0	48	0	522
Total	69	538	0	0	0	0	0	0	0	800	223	0	371	1	243	0	2245
Grand Total	346	2876	0	0	0	0	0	0	2	3210	1049	5	1381	3	1182	1	10055
Apprch %	10.7	89.3	0	0	0	0	0	0	0	75.2	24.6	0.1	53.8	0.1	46	0	
Total %	3.4	28.6	0	0	0	0	0	0	0	31.9	10.4	0	13.7	0	11.8	0	



MINNESOTA DEPT OF TRANSPORTATION

TRAFFIC DATA COLLECTION - METRO

TH-5 at TH-36 , south ramps STILLWATER
 Ref.Pt.: 201.189
 JAMAR # T-2638 CAH
 TURN MOVEMENT COUNT

File Name : TH-5 at TH-36 south ramps 2010
 Site Code : 00000000
 Start Date : 12/2/2010
 Page No : 2

Start Time	TH-5 Southbound					ramp to EB TH-36 Westbound					TH-5 Northbound					ramp from EB TH-36 Eastbound					Int. Total
	Left	Thru	Right	Peds	App. Total	Left	Thru	Right	Peds	App. Total	Left	Thru	Right	Peds	App. Total	Left	Thru	Right	Peds	App. Total	
Peak Hour Analysis From 06:00 to 08:45 - Peak 1 of 1																					
Peak Hour for Entire Intersection Begins at 08:00																					
08:00	8	103	0	0	111	0	0	0	0	0	0	70	38	0	108	44	0	36	0	80	299
08:15	11	111	0	0	122	0	0	0	0	0	0	94	37	0	131	37	0	39	0	76	329
08:30	7	114	0	0	121	0	0	0	0	0	0	101	45	0	146	45	0	48	0	93	360
08:45	25	98	0	0	123	0	0	0	0	0	0	123	45	0	168	50	0	54	0	104	395
Total Volume	51	426	0	0	477	0	0	0	0	0	0	388	165	0	553	176	0	177	0	353	1383
% App. Total	10.7	89.3	0	0		0	0	0	0		0	70.2	29.8	0		49.9	0	50.1	0		
PHF	.510	.934	.000	.000	.970	.000	.000	.000	.000	.000	.000	.789	.917	.000	.823	.880	.000	.819	.000	.849	.875

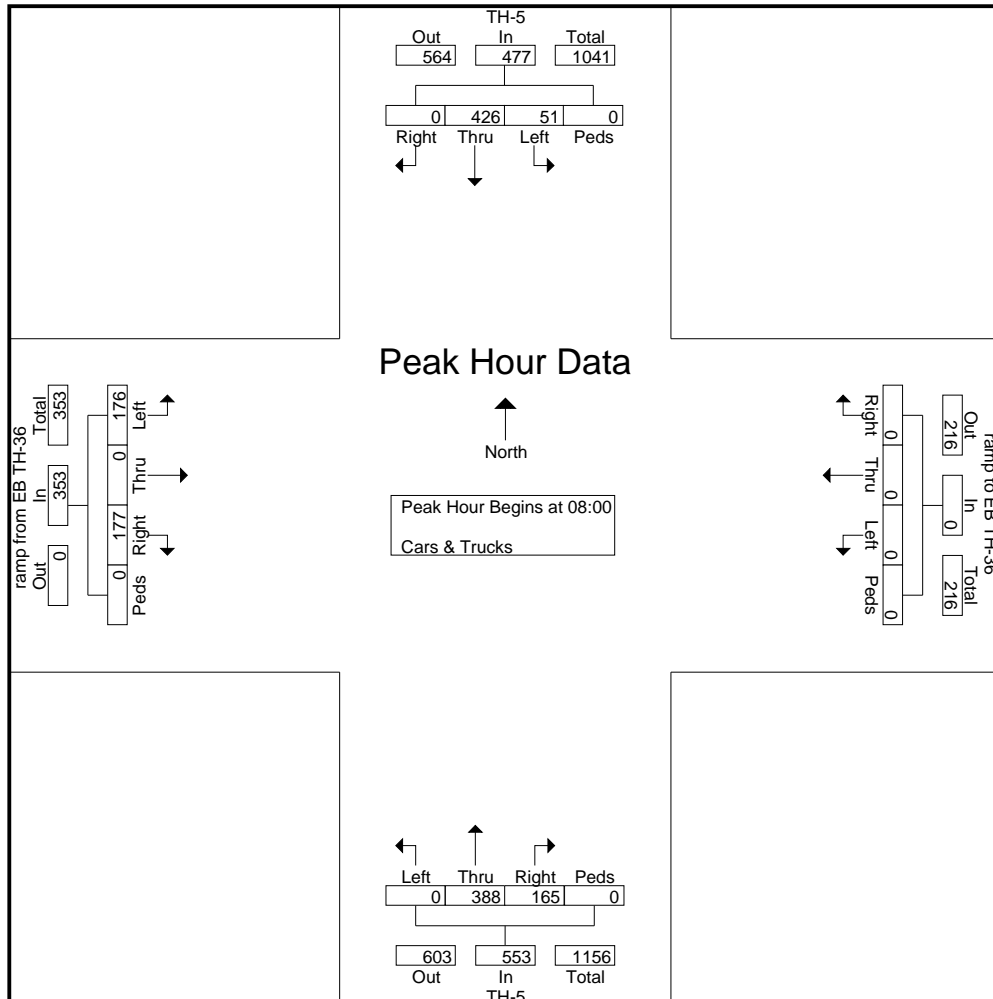



MINNESOTA DEPT OF TRANSPORTATION

TRAFFIC DATA COLLECTION - METRO

TH-5 at TH-36 , south ramps STILLWATER
 Ref.Pt.: 201.189
 JAMAR # T-2638 CAH
 TURN MOVEMENT COUNT

File Name : TH-5 at TH-36 south ramps 2010
 Site Code : 00000000
 Start Date : 12/2/2010
 Page No : 3

Start Time	TH-5 Southbound					ramp to EB TH-36 Westbound					TH-5 Northbound					ramp from EB TH-36 Eastbound					Int. Total
	Left	Thru	Right	Peds	App. Total	Left	Thru	Right	Peds	App. Total	Left	Thru	Right	Peds	App. Total	Left	Thru	Right	Peds	App. Total	
Peak Hour Analysis From 15:00 to 17:45 - Peak 1 of 1																					
Peak Hour for Entire Intersection Begins at 16:30																					
16:30	15	149	0	0	164	0	0	0	0	0	0	198	53	0	251	85	0	55	0	140	555
16:45	18	179	0	0	197	0	0	0	0	0	0	227	62	0	289	104	0	64	0	168	654
17:00	26	157	0	0	183	0	0	0	0	0	0	212	54	0	266	92	0	70	0	162	611
17:15	17	145	0	0	162	0	0	0	0	0	0	215	55	0	270	87	1	67	0	155	587
Total Volume	76	630	0	0	706	0	0	0	0	0	0	852	224	0	1076	368	1	256	0	625	2407
% App. Total	10.8	89.2	0	0		0	0	0	0		0	79.2	20.8	0		58.9	0.2	41	0		
PHF	.731	.880	.000	.000	.896	.000	.000	.000	.000	.000	.000	.938	.903	.000	.931	.885	.250	.914	.000	.930	.920

