



MINNESOTA DEPT OF TRANSPORTATION

TRAFFIC DATA COLLECTION - METRO

TH-5 at Venture Lane / Fuller Rd.
 Ref.Pt.: 048.249
 Data by: Westwood Professional Services
 TURN MOVEMENT COUNT

File Name : TH-5 at Venture Ln-Fuller Rd 2008
 Site Code : 19052001
 Start Date : 10/1/2008
 Page No : 1

Groups Printed- Unshifted

| Start Time | Venture Lane Southbound | | | | TH-5 Westbound | | | | Fuller Rd Northbound | | | | TH-5 Eastbound | | | | Int. Total |
|---------------|-------------------------|------|-------|------|----------------|-------|-------|------|----------------------|------|-------|------|----------------|-------|-------|------|------------|
| | Left | Thru | Right | Peds | Left | Thru | Right | Peds | Left | Thru | Right | Peds | Left | Thru | Right | Peds | |
| 06:00 | 0 | 1 | 1 | 0 | 27 | 170 | 0 | 0 | 3 | 1 | 6 | 0 | 2 | 224 | 6 | 0 | 441 |
| 06:15 | 0 | 1 | 2 | 0 | 33 | 174 | 2 | 0 | 0 | 1 | 5 | 0 | 5 | 350 | 10 | 0 | 583 |
| 06:30 | 1 | 9 | 2 | 0 | 42 | 230 | 10 | 0 | 1 | 0 | 4 | 0 | 5 | 405 | 15 | 0 | 724 |
| 06:45 | 0 | 13 | 5 | 0 | 33 | 229 | 14 | 0 | 0 | 1 | 5 | 0 | 7 | 408 | 13 | 0 | 728 |
| Total | 1 | 24 | 10 | 0 | 135 | 803 | 26 | 0 | 4 | 3 | 20 | 0 | 19 | 1387 | 44 | 0 | 2476 |
| 07:00 | 0 | 3 | 1 | 0 | 22 | 249 | 3 | 0 | 0 | 0 | 5 | 0 | 7 | 572 | 10 | 0 | 872 |
| 07:15 | 0 | 0 | 3 | 0 | 17 | 333 | 5 | 0 | 1 | 0 | 2 | 0 | 9 | 613 | 9 | 0 | 992 |
| 07:30 | 0 | 1 | 1 | 0 | 19 | 362 | 1 | 0 | 0 | 0 | 17 | 0 | 16 | 645 | 9 | 0 | 1071 |
| 07:45 | 0 | 0 | 3 | 0 | 26 | 314 | 3 | 0 | 1 | 0 | 8 | 0 | 22 | 690 | 17 | 0 | 1084 |
| Total | 0 | 4 | 8 | 0 | 84 | 1258 | 12 | 0 | 2 | 0 | 32 | 0 | 54 | 2520 | 45 | 0 | 4019 |
| 08:00 | 1 | 1 | 5 | 0 | 19 | 335 | 3 | 0 | 1 | 0 | 6 | 0 | 13 | 573 | 10 | 0 | 967 |
| 08:15 | 0 | 2 | 4 | 0 | 17 | 305 | 3 | 0 | 1 | 1 | 7 | 0 | 6 | 504 | 4 | 0 | 854 |
| 08:30 | 2 | 1 | 4 | 0 | 8 | 298 | 3 | 0 | 1 | 1 | 4 | 0 | 6 | 447 | 9 | 0 | 784 |
| 08:45 | 1 | 2 | 4 | 0 | 17 | 313 | 6 | 0 | 4 | 0 | 4 | 0 | 6 | 409 | 5 | 0 | 771 |
| Total | 4 | 6 | 17 | 0 | 61 | 1251 | 15 | 0 | 7 | 2 | 21 | 0 | 31 | 1933 | 28 | 0 | 3376 |
| *** BREAK *** | | | | | | | | | | | | | | | | | |
| 11:00 | 9 | 1 | 11 | 0 | 9 | 253 | 7 | 0 | 6 | 0 | 8 | 0 | 6 | 315 | 4 | 0 | 629 |
| 11:15 | 6 | 3 | 10 | 0 | 10 | 282 | 4 | 0 | 6 | 0 | 15 | 0 | 5 | 341 | 7 | 0 | 689 |
| 11:30 | 3 | 0 | 12 | 0 | 9 | 316 | 3 | 0 | 11 | 1 | 22 | 0 | 9 | 373 | 6 | 0 | 765 |
| 11:45 | 4 | 0 | 16 | 0 | 8 | 326 | 1 | 0 | 11 | 1 | 16 | 0 | 15 | 348 | 12 | 0 | 758 |
| Total | 22 | 4 | 49 | 0 | 36 | 1177 | 15 | 0 | 34 | 2 | 61 | 0 | 35 | 1377 | 29 | 0 | 2841 |
| 12:00 | 4 | 2 | 20 | 0 | 13 | 346 | 4 | 0 | 12 | 0 | 18 | 0 | 11 | 360 | 9 | 0 | 799 |
| 12:15 | 3 | 4 | 12 | 0 | 4 | 346 | 5 | 0 | 7 | 1 | 9 | 0 | 7 | 341 | 7 | 0 | 746 |
| 12:30 | 3 | 2 | 13 | 0 | 7 | 330 | 4 | 0 | 4 | 0 | 3 | 0 | 17 | 374 | 10 | 0 | 767 |
| 12:45 | 0 | 0 | 9 | 0 | 12 | 348 | 5 | 0 | 9 | 1 | 5 | 0 | 13 | 333 | 9 | 0 | 744 |
| Total | 10 | 8 | 54 | 0 | 36 | 1370 | 18 | 0 | 32 | 2 | 35 | 0 | 48 | 1408 | 35 | 0 | 3056 |
| *** BREAK *** | | | | | | | | | | | | | | | | | |
| 15:00 | 2 | 0 | 10 | 0 | 23 | 412 | 4 | 0 | 7 | 2 | 23 | 0 | 4 | 451 | 13 | 0 | 951 |
| 15:15 | 5 | 7 | 15 | 0 | 28 | 416 | 11 | 0 | 6 | 2 | 36 | 0 | 2 | 385 | 12 | 0 | 925 |
| 15:30 | 0 | 10 | 13 | 0 | 30 | 442 | 11 | 0 | 7 | 1 | 74 | 0 | 4 | 421 | 3 | 0 | 1016 |
| 15:45 | 2 | 3 | 18 | 0 | 16 | 466 | 5 | 0 | 11 | 1 | 27 | 0 | 3 | 351 | 4 | 0 | 907 |
| Total | 9 | 20 | 56 | 0 | 97 | 1736 | 31 | 0 | 31 | 6 | 160 | 0 | 13 | 1608 | 32 | 0 | 3799 |
| 16:00 | 1 | 2 | 15 | 0 | 4 | 492 | 2 | 0 | 13 | 1 | 32 | 0 | 3 | 352 | 5 | 0 | 922 |
| 16:15 | 2 | 1 | 28 | 0 | 5 | 533 | 4 | 0 | 10 | 1 | 18 | 0 | 4 | 352 | 9 | 0 | 967 |
| 16:30 | 1 | 1 | 21 | 0 | 7 | 526 | 1 | 0 | 20 | 1 | 23 | 0 | 8 | 430 | 4 | 0 | 1043 |
| 16:45 | 4 | 1 | 24 | 0 | 4 | 489 | 5 | 0 | 6 | 1 | 17 | 0 | 5 | 373 | 1 | 0 | 930 |
| Total | 8 | 5 | 88 | 0 | 20 | 2040 | 12 | 0 | 49 | 4 | 90 | 0 | 20 | 1507 | 19 | 0 | 3862 |
| 17:00 | 4 | 0 | 24 | 0 | 4 | 560 | 3 | 0 | 6 | 2 | 21 | 0 | 4 | 434 | 0 | 0 | 1062 |
| 17:15 | 1 | 2 | 20 | 0 | 1 | 539 | 1 | 0 | 7 | 1 | 20 | 0 | 4 | 415 | 4 | 0 | 1015 |
| 17:30 | 2 | 0 | 18 | 0 | 9 | 565 | 1 | 0 | 9 | 1 | 22 | 0 | 5 | 445 | 11 | 0 | 1088 |
| 17:45 | 1 | 0 | 10 | 0 | 2 | 546 | 5 | 0 | 10 | 2 | 14 | 0 | 6 | 335 | 3 | 0 | 934 |
| Total | 8 | 2 | 72 | 0 | 16 | 2210 | 10 | 0 | 32 | 6 | 77 | 0 | 19 | 1629 | 18 | 0 | 4099 |
| Grand Total | 62 | 73 | 354 | 0 | 485 | 11845 | 139 | 0 | 191 | 25 | 496 | 0 | 239 | 13369 | 250 | 0 | 27528 |
| Apprch % | 12.7 | 14.9 | 72.4 | 0 | 3.9 | 95 | 1.1 | 0 | 26.8 | 3.5 | 69.7 | 0 | 1.7 | 96.5 | 1.8 | 0 | |
| Total % | 0.2 | 0.3 | 1.3 | 0 | 1.8 | 43 | 0.5 | 0 | 0.7 | 0.1 | 1.8 | 0 | 0.9 | 48.6 | 0.9 | 0 | |



MINNESOTA DEPT OF TRANSPORTATION

TRAFFIC DATA COLLECTION - METRO

TH-5 at Venture Lane / Fuller Rd.
 Ref.Pt.: 048.249
 Data by: Westwood Professional Services
 TURN MOVEMENT COUNT

File Name : TH-5 at Venture Ln-Fuller Rd 2008
 Site Code : 19052001
 Start Date : 10/1/2008
 Page No : 2

| Start Time | Venture Lane Southbound | | | | | TH-5 Westbound | | | | | Fuller Rd Northbound | | | | | TH-5 Eastbound | | | | | Int. Total |
|--|-------------------------|------|-------|------|------------|----------------|------|-------|------|------------|----------------------|------|-------|------|------------|----------------|------|-------|------|------------|------------|
| | Left | Thru | Right | Peds | App. Total | Left | Thru | Right | Peds | App. Total | Left | Thru | Right | Peds | App. Total | Left | Thru | Right | Peds | App. Total | |
| Peak Hour Analysis From 06:00 to 08:45 - Peak 1 of 1 | | | | | | | | | | | | | | | | | | | | | |
| Peak Hour for Entire Intersection Begins at 07:15 | | | | | | | | | | | | | | | | | | | | | |
| 07:15 | 0 | 0 | 3 | 0 | 3 | 17 | 333 | 5 | 0 | 355 | 1 | 0 | 2 | 0 | 3 | 9 | 613 | 9 | 0 | 631 | 992 |
| 07:30 | 0 | 1 | 1 | 0 | 2 | 19 | 362 | 1 | 0 | 382 | 0 | 0 | 17 | 0 | 17 | 16 | 645 | 9 | 0 | 670 | 1071 |
| 07:45 | 0 | 0 | 3 | 0 | 3 | 26 | 314 | 3 | 0 | 343 | 1 | 0 | 8 | 0 | 9 | 22 | 690 | 17 | 0 | 729 | 1084 |
| 08:00 | 1 | 1 | 5 | 0 | 7 | 19 | 335 | 3 | 0 | 357 | 1 | 0 | 6 | 0 | 7 | 13 | 573 | 10 | 0 | 596 | 967 |
| Total Volume | 1 | 2 | 12 | 0 | 15 | 81 | 1344 | 12 | 0 | 1437 | 3 | 0 | 33 | 0 | 36 | 60 | 2521 | 45 | 0 | 2626 | 4114 |
| % App. Total | 6.7 | 13.3 | 80 | 0 | | 5.6 | 93.5 | 0.8 | 0 | | 8.3 | 0 | 91.7 | 0 | | 2.3 | 96 | 1.7 | 0 | | |
| PHF | .250 | .500 | .600 | .000 | .536 | .779 | .928 | .600 | .000 | .940 | .750 | .000 | .485 | .000 | .529 | .682 | .913 | .662 | .000 | .901 | .949 |

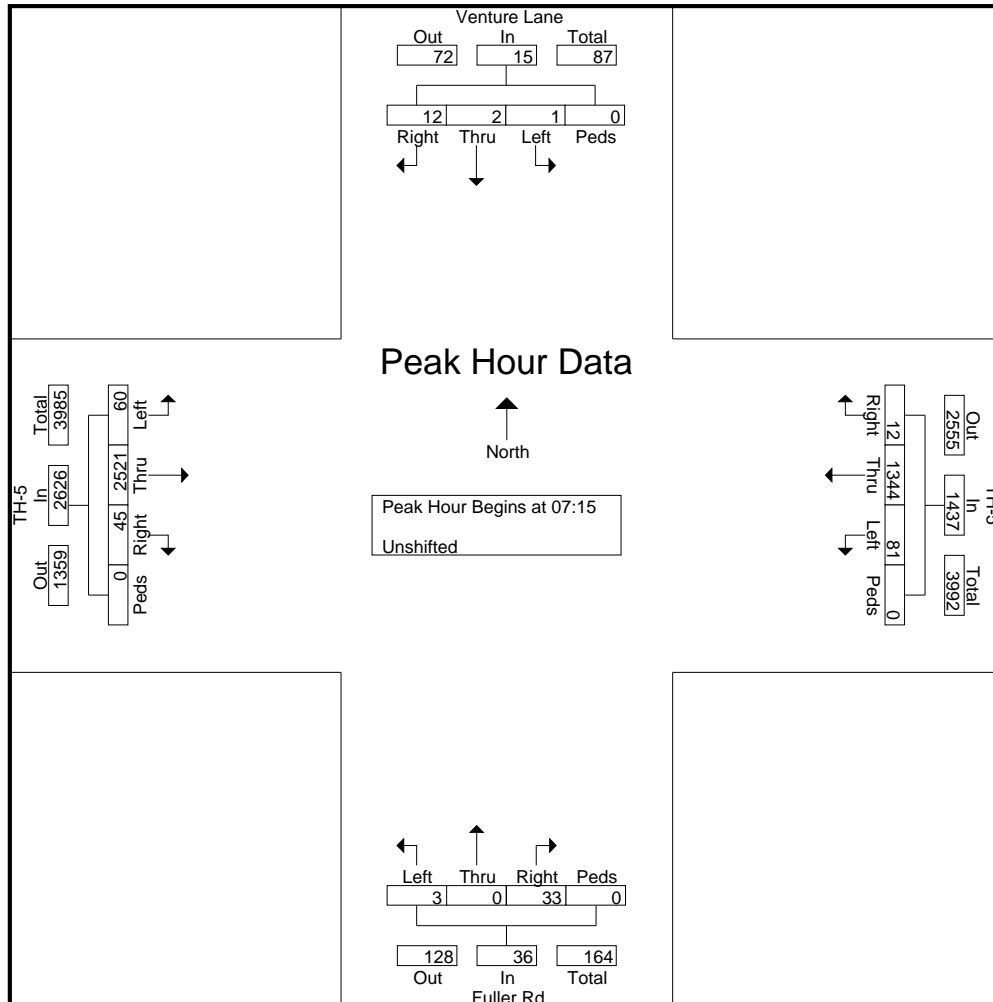



MINNESOTA DEPT OF TRANSPORTATION

TRAFFIC DATA COLLECTION - METRO

TH-5 at Venture Lane / Fuller Rd.
 Ref.Pt.: 048.249
 Data by: Westwood Professional Services
 TURN MOVEMENT COUNT

File Name : TH-5 at Venture Ln-Fuller Rd 2008
 Site Code : 19052001
 Start Date : 10/1/2008
 Page No : 3

| Start Time | Venture Lane Southbound | | | | | TH-5 Westbound | | | | | Fuller Rd Northbound | | | | | TH-5 Eastbound | | | | | Int. Total |
|------------|-------------------------|------|-------|------|------------|----------------|------|-------|------|------------|----------------------|------|-------|------|------------|----------------|------|-------|------|------------|------------|
| | Left | Thru | Right | Peds | App. Total | Left | Thru | Right | Peds | App. Total | Left | Thru | Right | Peds | App. Total | Left | Thru | Right | Peds | App. Total | |

Peak Hour Analysis From 15:00 to 17:45 - Peak 1 of 1

Peak Hour for Entire Intersection Begins at 17:00

| | | | | | | | | | | | | | | | | | | | | | |
|--------------|------|------|------|------|------|------|------|------|------|------|------|------|------|------|------|------|------|------|------|------|------|
| 17:00 | 4 | 0 | 24 | 0 | 28 | 4 | 560 | 3 | 0 | 567 | 6 | 2 | 21 | 0 | 29 | 4 | 434 | 0 | 0 | 438 | 1062 |
| 17:15 | 1 | 2 | 20 | 0 | 23 | 1 | 539 | 1 | 0 | 541 | 7 | 1 | 20 | 0 | 28 | 4 | 415 | 4 | 0 | 423 | 1015 |
| 17:30 | 2 | 0 | 18 | 0 | 20 | 9 | 565 | 1 | 0 | 575 | 9 | 1 | 22 | 0 | 32 | 5 | 445 | 11 | 0 | 461 | 1088 |
| 17:45 | 1 | 0 | 10 | 0 | 11 | 2 | 546 | 5 | 0 | 553 | 10 | 2 | 14 | 0 | 26 | 6 | 335 | 3 | 0 | 344 | 934 |
| Total Volume | 8 | 2 | 72 | 0 | 82 | 16 | 2210 | 10 | 0 | 2236 | 32 | 6 | 77 | 0 | 115 | 19 | 1629 | 18 | 0 | 1666 | 4099 |
| % App. Total | 9.8 | 2.4 | 87.8 | 0 | | 0.7 | 98.8 | 0.4 | 0 | | 27.8 | 5.2 | 67 | 0 | | 1.1 | 97.8 | 1.1 | 0 | | |
| PHF | .500 | .250 | .750 | .000 | .732 | .444 | .978 | .500 | .000 | .972 | .800 | .750 | .875 | .000 | .898 | .792 | .915 | .409 | .000 | .903 | .942 |

