



MINNESOTA DEPT OF TRANSPORTATION

TRAFFIC DATA COLLECTION - METRO

TH-47 at 142nd Ave NW
 Ref.Pt.: 022.420
 JAMAR # D4-3365 CAH
 TURN MOVEMENT COUNT

RAMSEY

File Name : TH-47 at 142nd Ave NW 2009
 Site Code : 00000000
 Start Date : 10/7/2009
 Page No : 1

Groups Printed- Cars & Trucks

Start Time	TH-47 / St Francis Blvd Southbound				142nd Ave NW Westbound				TH-47 / St Francis Blvd Northbound				142nd Ave NW Eastbound				Int. Total	
	Left	Thru	Right	Peds	Left	Thru	Right	Peds	Left	Thru	Right	Peds	Left	Thru	Right	Peds		
06:00	2	271	0	0	0	0	0	0	0	19	0	0	0	0	0	0	0	292
06:15	1	319	4	0	0	0	0	0	4	27	1	0	0	0	0	1	0	357
06:30	0	284	4	0	0	0	0	0	0	33	1	0	0	0	0	0	0	322
06:45	0	346	2	0	0	0	0	0	2	59	2	0	2	0	2	0	0	415
Total	3	1220	10	0	0	0	0	0	6	138	4	0	2	0	3	0	0	1386
07:00	0	383	7	1	0	0	0	0	0	40	3	0	0	0	0	0	0	434
07:15	0	344	7	0	0	0	0	0	1	64	2	0	0	0	0	0	0	418
07:30	0	177	7	0	0	0	0	0	1	17	1	0	0	0	1	0	0	204
07:45	3	269	6	0	0	0	0	0	3	76	7	0	0	0	1	0	0	365
Total	3	1173	27	1	0	0	0	0	5	197	13	0	0	0	2	0	0	1421
08:00	3	229	2	0	0	0	0	1	5	87	0	1	0	0	1	1	0	330
08:15	0	187	3	0	0	0	0	0	11	90	5	0	0	0	1	0	0	297
08:30	1	200	1	0	0	0	0	0	2	80	4	0	0	0	0	0	0	288
08:45	2	194	8	0	0	0	2	0	5	84	7	0	0	0	3	0	0	305
Total	6	810	14	0	0	0	2	1	23	341	16	1	0	0	5	1	0	1220
*** BREAK ***																		
15:00	2	113	2	0	0	0	10	0	6	225	19	0	1	0	4	0	0	382
15:15	2	138	2	0	0	0	3	0	11	243	10	0	0	0	3	0	0	412
15:30	2	159	1	0	0	0	7	0	15	276	7	0	0	0	4	0	0	471
15:45	9	139	0	0	0	0	0	0	6	245	7	0	0	0	2	0	0	408
Total	15	549	5	0	0	0	20	0	38	989	43	0	1	0	13	0	0	1673
16:00	1	112	1	1	0	0	0	0	5	106	2	0	1	0	1	0	0	230
16:15	6	202	4	0	0	0	2	0	12	307	12	3	0	0	2	0	0	550
16:30	7	204	4	0	0	0	9	0	12	304	8	3	0	0	5	0	0	556
16:45	7	200	2	0	0	0	1	0	14	305	6	0	0	0	1	0	0	536
Total	21	718	11	1	0	0	12	0	43	1022	28	6	1	0	9	0	0	1872
17:00	2	200	2	0	2	0	4	0	12	340	9	0	1	0	6	0	0	578
17:15	7	178	1	0	0	0	3	0	14	324	19	0	1	0	0	1	0	548
17:30	8	181	1	0	1	0	3	0	12	316	15	0	0	0	4	0	0	541
17:45	4	180	1	0	0	0	5	0	11	325	12	2	0	0	0	0	0	540
Total	21	739	5	0	3	0	15	0	49	1305	55	2	2	0	10	1	0	2207
Grand Total	69	5209	72	2	3	0	49	1	164	3992	159	9	6	0	42	2	0	9779
Apprch %	1.3	97.3	1.3	0	5.7	0	92.5	1.9	3.8	92.3	3.7	0.2	12	0	84	4	0	
Total %	0.7	53.3	0.7	0	0	0	0.5	0	1.7	40.8	1.6	0.1	0.1	0	0.4	0	0	



MINNESOTA DEPT OF TRANSPORTATION

TRAFFIC DATA COLLECTION - METRO

TH-47 at 142nd Ave NW

RAMSEY

File Name : TH-47 at 142nd Ave NW 2009

Ref.Pt.: 022.420

Site Code : 00000000

JAMAR # D4-3365 CAH

Start Date : 10/7/2009

TURN MOVEMENT COUNT

Page No : 2

Start Time	TH-47 / St Francis Blvd Southbound					142nd Ave NW Westbound					TH-47 / St Francis Blvd Northbound					142nd Ave NW Eastbound					Int. Total
	Left	Thru	Right	Peds	App. Total	Left	Thru	Right	Peds	App. Total	Left	Thru	Right	Peds	App. Total	Left	Thru	Right	Peds	App. Total	
Peak Hour Analysis From 06:00 to 08:45 - Peak 1 of 1																					
Peak Hour for Entire Intersection Begins at 06:30																					
06:30	0	284	4	0	288	0	0	0	0	0	0	33	1	0	34	0	0	0	0	0	322
06:45	0	346	2	0	348	0	0	0	0	0	2	59	2	0	63	2	0	2	0	4	415
07:00	0	383	7	1	391	0	0	0	0	0	0	40	3	0	43	0	0	0	0	0	434
07:15	0	344	7	0	351	0	0	0	0	0	1	64	2	0	67	0	0	0	0	0	418
Total Volume	0	1357	20	1	1378	0	0	0	0	0	3	196	8	0	207	2	0	2	0	4	1589
% App. Total	0	98.5	1.5	0.1		0	0	0	0		1.4	94.7	3.9	0		50	0	50	0		
PHF	.000	.886	.714	.250	.881	.000	.000	.000	.000	.000	.375	.766	.667	.000	.772	.250	.000	.250	.000	.250	.915

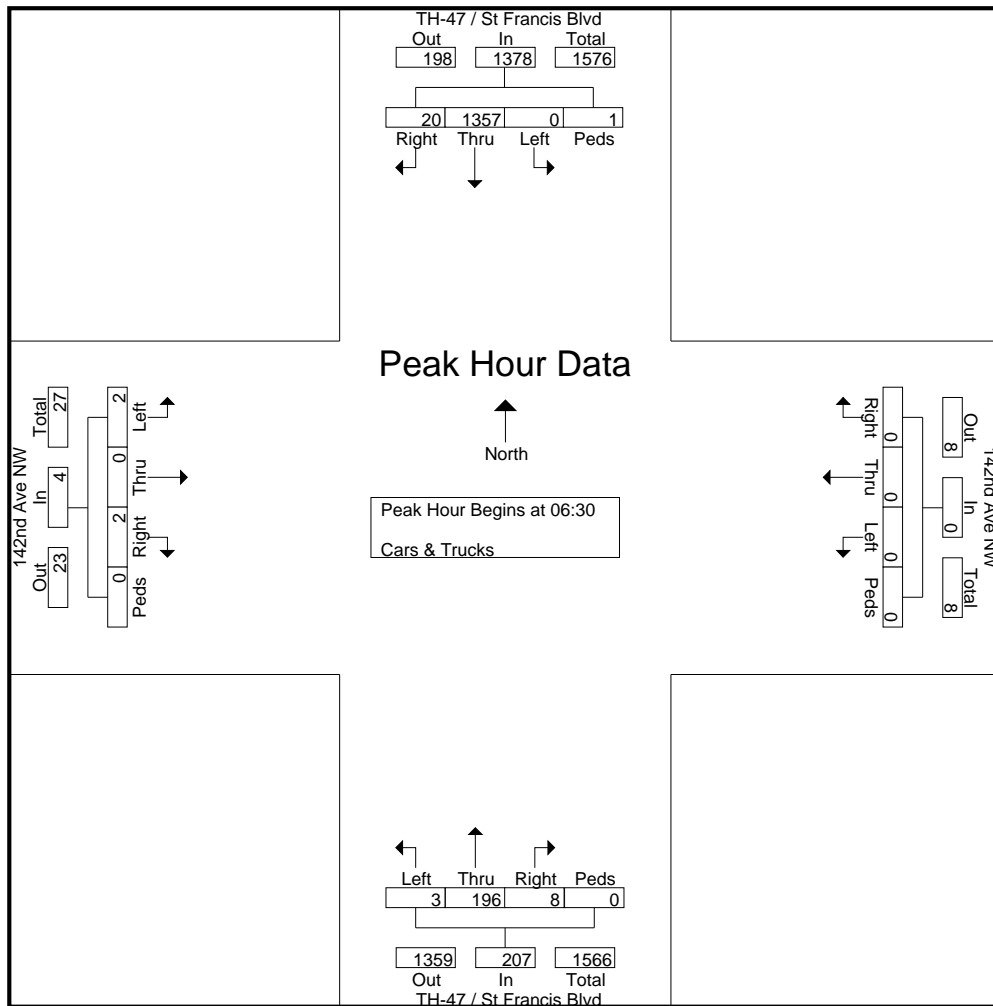



MINNESOTA DEPT OF TRANSPORTATION

TRAFFIC DATA COLLECTION - METRO

TH-47 at 142nd Ave NW
 Ref.Pt.: 022.420
 JAMAR # D4-3365 CAH
 TURN MOVEMENT COUNT

RAMSEY

File Name : TH-47 at 142nd Ave NW 2009
 Site Code : 00000000
 Start Date : 10/7/2009
 Page No : 3

Start Time	TH-47 / St Francis Blvd Southbound					142nd Ave NW Westbound					TH-47 / St Francis Blvd Northbound					142nd Ave NW Eastbound					Int. Total
	Left	Thru	Right	Peds	App. Total	Left	Thru	Right	Peds	App. Total	Left	Thru	Right	Peds	App. Total	Left	Thru	Right	Peds	App. Total	
16:15	6	202	4	0	212	0	0	2	0	2	12	307	12	3	334	0	0	2	0	2	550
16:30	7	204	4	0	215	0	0	9	0	9	12	304	8	3	327	0	0	5	0	5	556
16:45	7	200	2	0	209	0	0	1	0	1	14	305	6	0	325	0	0	1	0	1	536
17:00	2	200	2	0	204	2	0	4	0	6	12	340	9	0	361	1	0	6	0	7	578
Total Volume	22	806	12	0	840	2	0	16	0	18	50	1256	35	6	1347	1	0	14	0	15	2220
% App. Total	2.6	96	1.4	0		11.1	0	88.9	0		3.7	93.2	2.6	0.4		6.7	0	93.3	0		
PHF	.786	.988	.750	.000	.977	.250	.000	.444	.000	.500	.893	.924	.729	.500	.933	.250	.000	.583	.000	.536	.960

Peak Hour Analysis From 15:00 to 17:45 - Peak 1 of 1
 Peak Hour for Entire Intersection Begins at 16:15

