

Albeck Gerken, Inc

Transportation Engineers

Traffic Data Collection

TH-47 / University Ave at 61st Ave NE

Ref.Pt.: 008.385

Data by: Albeck Gerken Inc

TURN MOVEMENT COUNT

File Name : TH-47 at 61st Ave NE

Site Code : 01828192

Start Date : 7/15/2008

Page No : 1

Groups Printed- Unshifted

Start Time	TH-47 / University Avenue Southbound				61st Avenue NE Westbound				TH-47 / University Avenue Northbound				61st Avenue NE Eastbound				Int. Total
	Left	Thru	Right	Peds	Left	Thru	Right	Peds	Left	Thru	Right	Peds	Left	Thru	Right	Peds	
06:00	3	258	12	1	6	1	3	0	0	96	15	4	5	1	5	0	410
06:15	5	298	10	0	10	0	1	1	2	105	12	4	3	1	5	0	457
06:30	3	410	13	1	9	2	8	0	1	160	9	0	6	3	7	0	632
06:45	5	350	17	1	14	2	5	1	2	182	17	1	6	1	6	0	610
Total	16	1316	52	3	39	5	17	2	5	543	53	9	20	6	23	0	2109
07:00	5	406	12	0	8	4	5	0	3	130	12	5	1	2	6	0	599
07:15	4	404	13	0	17	6	1	0	0	161	14	2	9	4	7	0	642
07:30	12	461	14	0	13	4	4	1	0	142	28	7	3	7	7	0	703
07:45	4	365	17	2	16	9	11	0	0	175	32	6	9	5	7	1	659
Total	25	1636	56	2	54	23	21	1	3	608	86	20	22	18	27	1	2603
08:00	4	389	16	0	19	13	4	0	2	153	22	1	4	3	5	0	635
08:15	12	293	9	3	22	8	7	0	1	159	20	2	5	3	6	1	551
08:30	6	261	6	0	23	5	6	0	2	165	19	0	10	7	8	0	518
08:45	8	181	8	0	13	3	9	1	3	183	26	4	9	2	1	0	451
Total	30	1124	39	3	77	29	26	1	8	660	87	7	28	15	20	1	2155
*** BREAK ***																	
11:00	15	191	9	3	20	7	15	0	0	179	18	2	4	4	6	0	473
11:15	10	227	11	0	28	2	9	0	3	189	27	10	11	10	4	0	541
11:30	7	204	4	2	28	6	7	0	5	193	26	4	14	7	4	0	511
11:45	9	205	6	0	24	4	11	0	2	212	30	5	7	9	7	1	532
Total	41	827	30	5	100	19	42	0	10	773	101	21	36	30	21	1	2057
12:00	7	234	9	0	28	10	10	0	6	202	20	0	16	7	2	0	551
12:15	13	205	12	0	26	8	16	0	1	192	30	3	11	16	4	1	538
12:30	6	202	9	1	22	7	8	0	2	239	41	1	8	9	3	1	559
12:45	9	204	10	1	26	4	16	0	1	217	27	0	12	6	1	1	535
Total	35	845	40	2	102	29	50	0	10	850	118	4	47	38	10	3	2183
*** BREAK ***																	
15:00	6	236	12	3	24	2	14	0	4	341	26	0	19	8	3	0	698
15:15	10	203	14	0	18	2	12	0	6	323	28	0	17	7	2	0	642
15:30	11	266	10	2	21	8	11	0	2	333	26	0	30	11	5	0	736
15:45	7	227	10	1	11	8	7	0	5	418	16	1	16	8	3	0	738
Total	34	932	46	6	74	20	44	0	17	1415	96	1	82	34	13	0	2814
16:00	9	237	10	1	18	5	11	2	3	337	32	2	20	7	6	0	700
16:15	4	220	10	3	25	8	9	1	3	409	31	0	15	11	2	1	752
16:30	13	254	15	0	27	7	7	0	7	420	29	0	26	9	2	0	816
16:45	9	228	17	3	24	6	5	0	5	367	18	1	15	10	6	0	714
Total	35	939	52	7	94	26	32	3	18	1533	110	3	76	37	16	1	2982
17:00	15	198	8	3	33	6	11	2	6	374	25	0	25	10	7	1	724
17:15	8	217	12	2	27	9	8	3	5	391	27	1	19	8	0	0	737
17:30	13	216	18	0	27	5	12	0	3	408	33	1	14	8	4	0	762
17:45	11	147	9	1	22	7	9	0	5	411	43	1	9	12	5	0	692
Total	47	778	47	6	109	27	40	5	19	1584	128	3	67	38	16	1	2915
Grand Total	263	8397	362	34	649	178	272	12	90	7966	779	68	378	216	146	8	19818
Apprch %	2.9	92.7	4	0.4	58.4	16	24.5	1.1	1	89.5	8.7	0.8	50.5	28.9	19.5	1.1	
Total %	1.3	42.4	1.8	0.2	3.3	0.9	1.4	0.1	0.5	40.2	3.9	0.3	1.9	1.1	0.7	0	

Albeck Gerken, Inc

Transportation Engineers

Traffic Data Collection

TH-47 / University Ave at 61st Ave NE

Ref.Pt.: 008.385

Data by: Albeck Gerken Inc

TURN MOVEMENT COUNT

File Name : TH-47 at 61st Ave NE

Site Code : 01828192

Start Date : 7/15/2008

Page No : 2

Start Time	TH-47 / University Avenue Southbound					61st Avenue NE Westbound					TH-47 / University Avenue Northbound					61st Avenue NE Eastbound					Int. Total
	Left	Thru	Right	Peds	App. Total	Left	Thru	Right	Peds	App. Total	Left	Thru	Right	Peds	App. Total	Left	Thru	Right	Peds	App. Total	
Peak Hour Analysis From 06:00 to 08:45 - Peak 1 of 1																					
Peak Hour for Entire Intersection Begins at 07:15																					
07:15	4	404	13	0	421	17	6	1	0	24	0	161	14	2	177	9	4	7	0	20	642
07:30	12	461	14	0	487	13	4	4	1	22	0	142	28	7	177	3	7	7	0	17	703
07:45	4	365	17	2	388	16	9	11	0	36	0	175	32	6	213	9	5	7	1	22	659
08:00	4	389	16	0	409	19	13	4	0	36	2	153	22	1	178	4	3	5	0	12	635
Total Volume	24	1619	60	2	1705	65	32	20	1	118	2	631	96	16	745	25	19	26	1	71	2639
% App. Total	1.4	95	3.5	0.1		55.1	27.1	16.9	0.8		0.3	84.7	12.9	2.1		35.2	26.8	36.6	1.4		
PHF	.500	.878	.882	.250	.875	.855	.615	.455	.250	.819	.250	.901	.750	.571	.874	.694	.679	.929	.250	.807	.938

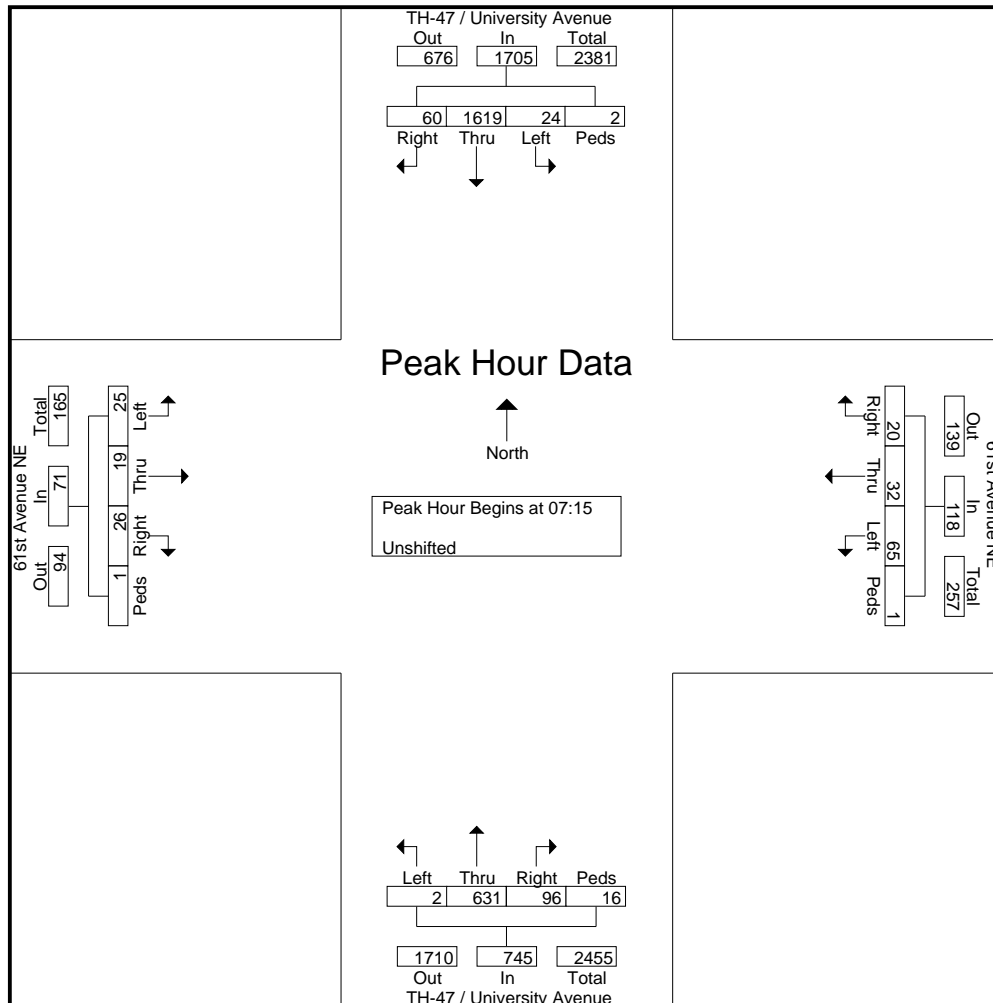

Albeck Gerken, Inc

Transportation Engineers

Traffic Data Collection

TH-47 / University Ave at 61st Ave NE

Ref.Pt.: 008.385

Data by: Albeck Gerken Inc

TURN MOVEMENT COUNT

File Name : TH-47 at 61st Ave NE

Site Code : 01828192

Start Date : 7/15/2008

Page No : 3

Start Time	TH-47 / University Avenue Southbound					61st Avenue NE Westbound					TH-47 / University Avenue Northbound					61st Avenue NE Eastbound					Int. Total
	Left	Thru	Right	Peds	App. Total	Left	Thru	Right	Peds	App. Total	Left	Thru	Right	Peds	App. Total	Left	Thru	Right	Peds	App. Total	
Peak Hour Analysis From 15:00 to 17:45 - Peak 1 of 1																					
Peak Hour for Entire Intersection Begins at 15:45																					
15:45	7	227	10	1	245	11	8	7	0	26	5	418	16	1	440	16	8	3	0	27	738
16:00	9	237	10	1	257	18	5	11	2	36	3	337	32	2	374	20	7	6	0	33	700
16:15	4	220	10	3	237	25	8	9	1	43	3	409	31	0	443	15	11	2	1	29	752
16:30	13	254	15	0	282	27	7	7	0	41	7	420	29	0	456	26	9	2	0	37	816
Total Volume	33	938	45	5	1021	81	28	34	3	146	18	1584	108	3	1713	77	35	13	1	126	3006
% App. Total	3.2	91.9	4.4	0.5		55.5	19.2	23.3	2.1		1.1	92.5	6.3	0.2		61.1	27.8	10.3	0.8		
PHF	.635	.923	.750	.417	.905	.750	.875	.773	.375	.849	.643	.943	.844	.375	.939	.740	.795	.542	.250	.851	.921

