

Albeck Gerken, Inc

Transportation Engineers

Traffic Data Collection

TH-47 at 49th Ave NE

Ref.Pt.: 006.869

Data by: Albeck Gerkin Inc

TURN MOVEMENT COUNT

File Name : TH-47 at 49th Ave NE 2008

Site Code : 01828141

Start Date : 7/10/2008

Page No : 1

Groups Printed- Unshifted

Start Time	TH-47 / University Ave Southbound				49th Ave NE Westbound				TH-47 / University Ave Northbound				49th Ave NE Eastbound				Int. Total
	Left	Thru	Right	Peds	Left	Thru	Right	Peds	Left	Thru	Right	Peds	Left	Thru	Right	Peds	
06:00	3	142	3	0	12	4	10	0	0	61	3	1	5	2	5	0	251
06:15	12	183	5	2	15	2	18	0	0	77	0	0	1	1	12	1	329
06:30	6	221	6	0	17	8	28	2	0	96	1	7	4	3	4	2	405
06:45	11	302	6	0	18	5	19	0	3	84	0	0	12	3	3	1	467
Total	32	848	20	2	62	19	75	2	3	318	4	8	22	9	24	4	1452
07:00	10	227	6	0	23	7	23	1	2	84	1	2	6	5	5	0	402
07:15	8	252	5	0	19	11	25	0	0	100	4	5	11	0	9	1	450
07:30	11	271	6	1	25	19	27	0	3	120	2	1	9	4	3	0	502
07:45	15	272	13	0	16	9	14	0	2	113	7	3	8	8	6	0	486
Total	44	1022	30	1	83	46	89	1	7	417	14	11	34	17	23	1	1840
08:00	6	182	8	1	22	11	20	2	1	111	6	0	7	2	3	0	382
08:15	7	200	8	0	19	6	21	0	3	106	2	1	8	1	4	0	386
08:30	6	147	1	3	9	10	19	0	1	109	7	1	9	6	4	0	332
08:45	10	165	5	1	16	10	11	0	1	92	6	1	7	4	1	1	331
Total	29	694	22	5	66	37	71	2	6	418	21	3	31	13	12	1	1431
*** BREAK ***																	
11:00	9	113	5	2	7	12	17	2	3	112	8	0	9	13	5	0	317
11:15	20	112	12	0	8	14	24	2	3	101	10	1	12	7	2	0	328
11:30	22	104	4	2	12	10	22	2	5	126	12	0	7	9	4	0	341
11:45	17	139	3	3	11	15	12	1	3	109	13	1	8	7	2	0	344
Total	68	468	24	7	38	51	75	7	14	448	43	2	36	36	13	0	1330
12:00	15	125	2	2	14	12	16	3	3	131	17	2	11	14	2	1	370
12:15	28	132	9	4	7	12	18	3	4	104	14	0	3	6	7	0	351
12:30	24	147	12	0	9	15	12	2	3	121	14	1	7	8	2	0	377
12:45	22	130	6	0	8	7	20	2	1	149	10	0	8	8	3	0	374
Total	89	534	29	6	38	46	66	10	11	505	55	3	29	36	14	1	1472
*** BREAK ***																	
15:00	27	136	5	1	9	3	27	0	2	185	8	0	11	10	6	0	430
15:15	26	137	11	2	8	11	22	4	3	194	21	0	9	5	5	0	458
15:30	25	162	9	1	13	10	24	1	1	245	13	1	7	9	5	0	526
15:45	20	133	8	0	8	9	20	0	4	241	14	3	13	19	4	1	497
Total	98	568	33	4	38	33	93	5	10	865	56	4	40	43	20	1	1911
16:00	39	148	7	0	15	12	14	0	6	258	17	0	12	8	5	0	541
16:15	26	161	14	1	7	9	14	1	7	269	14	1	6	18	1	0	549
16:30	27	147	10	0	12	18	15	1	9	337	23	1	7	9	4	0	620
16:45	34	159	10	4	8	13	21	0	9	282	34	1	8	13	5	0	601
Total	126	615	41	5	42	52	64	2	31	1146	88	3	33	48	15	0	2311
17:00	28	146	4	3	12	14	23	2	7	292	25	0	3	19	5	1	584
17:15	26	158	10	0	12	22	19	0	2	330	25	0	10	14	6	0	634
17:30	23	149	7	5	15	16	22	3	3	266	33	5	6	15	1	0	569
17:45	44	144	12	2	12	11	17	4	5	198	14	0	6	15	3	0	487
Total	121	597	33	10	51	63	81	9	17	1086	97	5	25	63	15	1	2274
Grand Total	607	5346	232	40	418	347	614	38	99	5203	378	39	250	265	136	9	14021
Apprch %	9.8	85.9	3.7	0.6	29.5	24.5	43.3	2.7	1.7	91	6.6	0.7	37.9	40.2	20.6	1.4	
Total %	4.3	38.1	1.7	0.3	3	2.5	4.4	0.3	0.7	37.1	2.7	0.3	1.8	1.9	1	0.1	

Albeck Gerken, Inc

Transportation Engineers

Traffic Data Collection

TH-47 at 49th Ave NE
 Ref.Pt.: 006.869
 Data by: Albeck Gerkin Inc
 TURN MOVEMENT COUNT

File Name : TH-47 at 49th Ave NE 2008
 Site Code : 01828141
 Start Date : 7/10/2008
 Page No : 2

Start Time	TH-47 / University Ave Southbound					49th Ave NE Westbound					TH-47 / University Ave Northbound					49th Ave NE Eastbound					Int. Total
	Left	Thru	Right	Peds	App. Total	Left	Thru	Right	Peds	App. Total	Left	Thru	Right	Peds	App. Total	Left	Thru	Right	Peds	App. Total	
Peak Hour Analysis From 06:00 to 08:45 - Peak 1 of 1																					
Peak Hour for Entire Intersection Begins at 07:00																					
07:00	10	227	6	0	243	23	7	23	1	54	2	84	1	2	89	6	5	5	0	16	402
07:15	8	252	5	0	265	19	11	25	0	55	0	100	4	5	109	11	0	9	1	21	450
07:30	11	271	6	1	289	25	19	27	0	71	3	120	2	1	126	9	4	3	0	16	502
07:45	15	272	13	0	300	16	9	14	0	39	2	113	7	3	125	8	8	6	0	22	486
Total Volume	44	1022	30	1	1097	83	46	89	1	219	7	417	14	11	449	34	17	23	1	75	1840
% App. Total	4	93.2	2.7	0.1		37.9	21	40.6	0.5		1.6	92.9	3.1	2.4		45.3	22.7	30.7	1.3		
PHF	.733	.939	.577	.250	.914	.830	.605	.824	.250	.771	.583	.869	.500	.550	.891	.773	.531	.639	.250	.852	.916

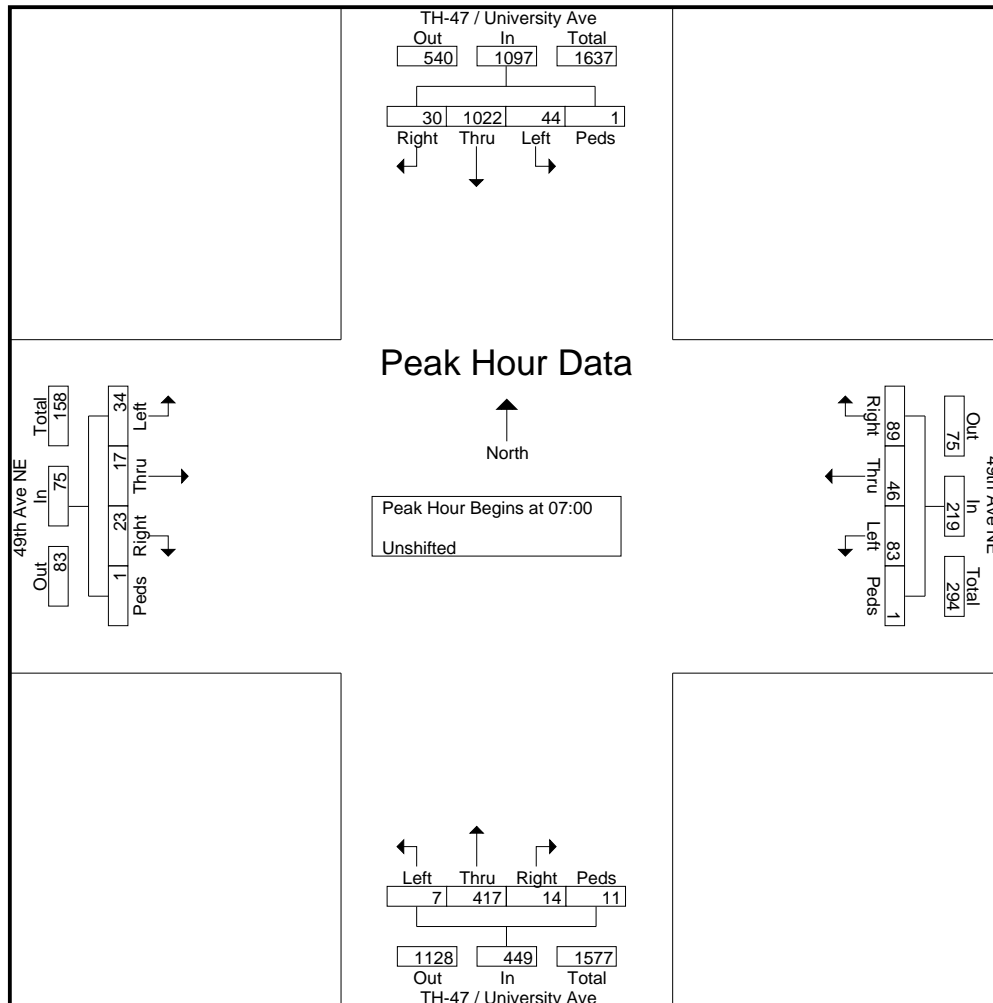

Albeck Gerken, Inc

Transportation Engineers

Traffic Data Collection

TH-47 at 49th Ave NE
 Ref.Pt.: 006.869
 Data by: Albeck Gerkin Inc
 TURN MOVEMENT COUNT

File Name : TH-47 at 49th Ave NE 2008
 Site Code : 01828141
 Start Date : 7/10/2008
 Page No : 3

Start Time	TH-47 / University Ave Southbound					49th Ave NE Westbound					TH-47 / University Ave Northbound					49th Ave NE Eastbound					Int. Total
	Left	Thru	Right	Peds	App. Total	Left	Thru	Right	Peds	App. Total	Left	Thru	Right	Peds	App. Total	Left	Thru	Right	Peds	App. Total	
Peak Hour Analysis From 15:00 to 17:45 - Peak 1 of 1																					
Peak Hour for Entire Intersection Begins at 16:30																					
16:30	27	147	10	0	184	12	18	15	1	46	9	337	23	1	370	7	9	4	0	20	620
16:45	34	159	10	4	207	8	13	21	0	42	9	282	34	1	326	8	13	5	0	26	601
17:00	28	146	4	3	181	12	14	23	2	51	7	292	25	0	324	3	19	5	1	28	584
17:15	26	158	10	0	194	12	22	19	0	53	2	330	25	0	357	10	14	6	0	30	634
Total Volume	115	610	34	7	766	44	67	78	3	192	27	1241	107	2	1377	28	55	20	1	104	2439
% App. Total	15	79.6	4.4	0.9		22.9	34.9	40.6	1.6		2	90.1	7.8	0.1		26.9	52.9	19.2	1		
PHF	.846	.959	.850	.438	.925	.917	.761	.848	.375	.906	.750	.921	.787	.500	.930	.700	.724	.833	.250	.867	.962

