

ALLIANT ENGINEERING, INC.

733 S Marquette Ave #700, Minneapolis, MN 55402

Intersection: TH 47 & 37th Avenue
 Date: 3/19/2024
 Duration: 0600-1800

Site Code: 601
 Ref Pt: N/A
 Page No: 2 of 4

All Vehicles (Cars & Trucks) Printed

Start Time	TH 47 Southbound						37th Avenue Westbound						TH 47 Northbound						37th Avenue Eastbound						Int. Veh. Total	Int. Ped/Bike Total
	U-Turn	Left	Thru	Right	App. Total	Peds/Bikes	U-Turn	Left	Thru	Right	App. Total	Peds/Bikes	U-Turn	Left	Thru	Right	App. Total	Peds/Bikes	U-Turn	Left	Thru	Right	App. Total	Peds/Bikes		
7:30	--	24	196	8	228	1	--	27	4	33	64	--	--	3	97	9	109	1	--	10	5	18	33	--	434	2
7:45	1	31	261	10	303	--	--	20	7	25	52	--	--	5	120	11	136	1	--	13	7	15	35	--	526	1
8:00	--	13	194	8	215	--	--	26	8	25	59	--	--	2	83	14	99	1	--	12	1	13	26	1	399	2
8:15	--	19	177	12	208	--	--	31	4	16	51	--	--	6	90	11	107	--	--	5	5	12	22	--	388	--
Hour Total	1	87	828	38	954	1	--	104	23	99	226	--	--	16	390	45	451	3	--	40	18	58	116	1	1747	5
% of App.	0.1%	9.1%	86.8%	4.0%			0.0%	46.0%	10.2%	43.8%			0.0%	3.5%	86.5%	10.0%			0.0%	34.5%	15.5%	50.0%				
% of Total	0.1%	5.0%	47.4%	2.2%	54.6%	20.0%	0.0%	6.0%	1.3%	5.7%	12.9%	0.0%	0.0%	0.9%	22.3%	2.6%	25.8%	60.0%	0.0%	2.3%	1.0%	3.3%	6.6%	20.0%		
Cars Total	1	81	791	34	907	1	--	99	23	94	216	--	--	15	363	39	417	3	--	38	13	57	108	1	1648	5
Cars % of Movement	100%	93.1%	95.5%	89.5%	95.1%	20.0%	0.0%	95.2%	100%	94.9%	95.6%	0.0%	0.0%	93.8%	93.1%	86.7%	92.5%	60.0%	0.0%	95.0%	72.2%	98.3%	93.1%	20.0%	94.3%	
Trucks Total	--	6	37	4	47	--	--	5	--	5	10	--	--	1	27	6	34	--	--	2	5	1	8	--	99	--
Trucks % of Movement	0.0%	6.9%	4.5%	10.5%	4.9%	--	0.0%	4.8%	0.0%	5.1%	4.4%	--	0.0%	6.3%	6.9%	13.3%	7.5%	--	0.0%	5.0%	27.8%	1.7%	6.9%	--	5.7%	

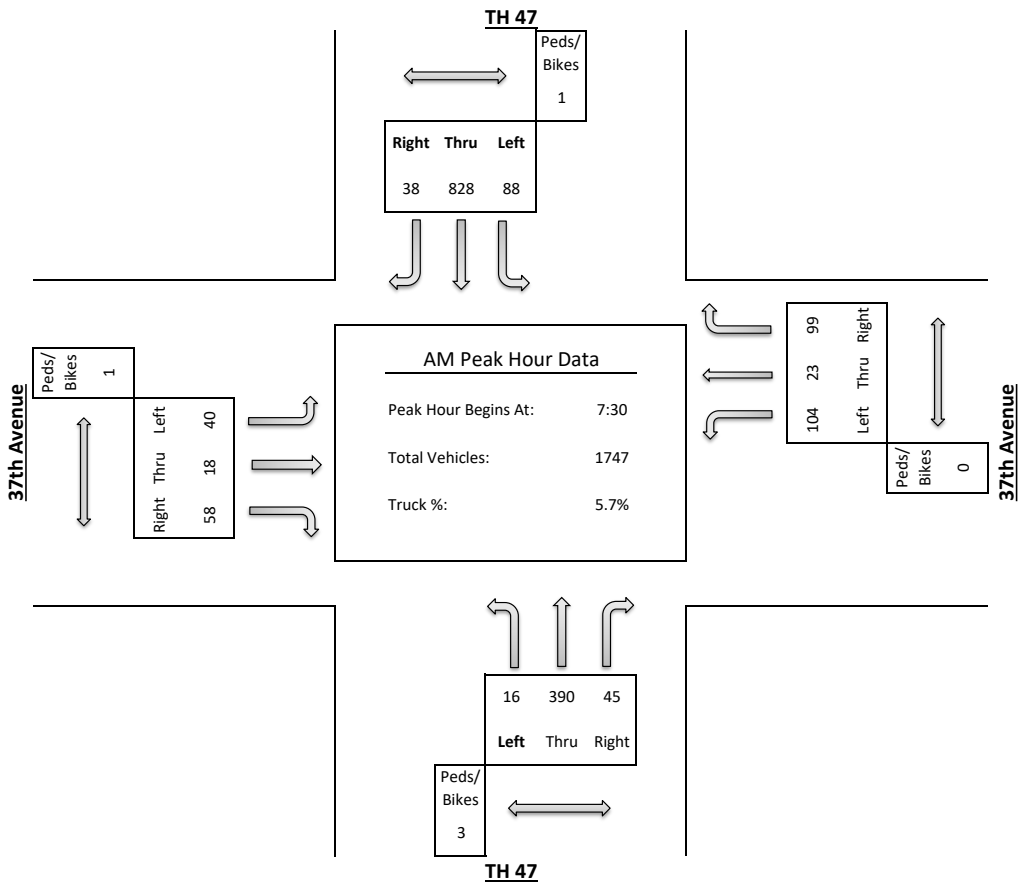

ALLIANT ENGINEERING, INC.

733 S Marquette Ave #700, Minneapolis, MN 55402

Intersection: TH 47 & 37th Avenue
 Date: 3/19/2024
 Duration: 0600-1800

Site Code: 601
 Ref Pt: N/A
 Page No: 3 of 4

All Vehicles (Cars & Trucks) Printed

Start Time	TH 47 Southbound						37th Avenue Westbound						TH 47 Northbound						37th Avenue Eastbound						Int. Veh. Total	Int. Ped/Bike Total
	U-Turn	Left	Thru	Right	App. Total	Peds/Bikes	U-Turn	Left	Thru	Right	App. Total	Peds/Bikes	U-Turn	Left	Thru	Right	App. Total	Peds/Bikes	U-Turn	Left	Thru	Right	App. Total	Peds/Bikes		
11:30	--	16	90	4	110	--	--	18	6	19	43	--	--	5	86	12	103	--	--	6	4	1	11	--	267	--
11:45	3	31	85	10	129	1	--	15	11	23	49	--	2	5	87	14	108	--	--	9	7	6	22	--	308	1
12:00	--	13	84	5	102	1	--	14	2	24	40	--	1	3	79	15	98	--	--	8	6	4	18	--	258	1
12:15	--	17	78	10	105	1	--	19	3	24	46	--	1	5	71	15	92	--	--	7	5	5	17	--	260	1
Hour Total	3	77	337	29	446	3	--	66	22	90	178	--	4	18	323	56	401	--	--	30	22	16	68	--	1093	3
% of App.	0.7%	17.3%	75.6%	6.5%			0.0%	37.1%	12.4%	50.6%			1.0%	4.5%	80.5%	14.0%			0.0%	44.1%	32.4%	23.5%				
% of Total	0.3%	7.0%	30.8%	2.7%	40.8%	#####	0.0%	6.0%	2.0%	8.2%	16.3%	0.0%	0.4%	1.6%	29.6%	5.1%	36.7%	0.0%	0.0%	2.7%	2.0%	1.5%	6.2%	0.0%		
Cars Total	3	67	300	27	397	3	--	64	21	86	171	--	4	18	309	49	380	--	--	26	21	16	63	--	1011	3
Cars % of Movement	100%	87.0%	89.0%	93.1%	89.0%	#####	0.0%	97.0%	95.5%	95.6%	96.1%	0.0%	100%	100%	95.7%	87.5%	94.8%	0.0%	0.0%	86.7%	95.5%	100%	92.6%	0.0%	92.5%	
Trucks Total	--	10	37	2	49	--	--	2	1	4	7	--	--	--	14	7	21	--	--	4	1	--	5	--	82	--
Trucks % of Movement	0.0%	13.0%	11.0%	6.9%	11.0%	--	0.0%	3.0%	4.5%	4.4%	3.9%	--	0.0%	0.0%	4.3%	12.5%	5.2%	--	0.0%	13.3%	4.5%	0.0%	7.4%	--	7.5%	

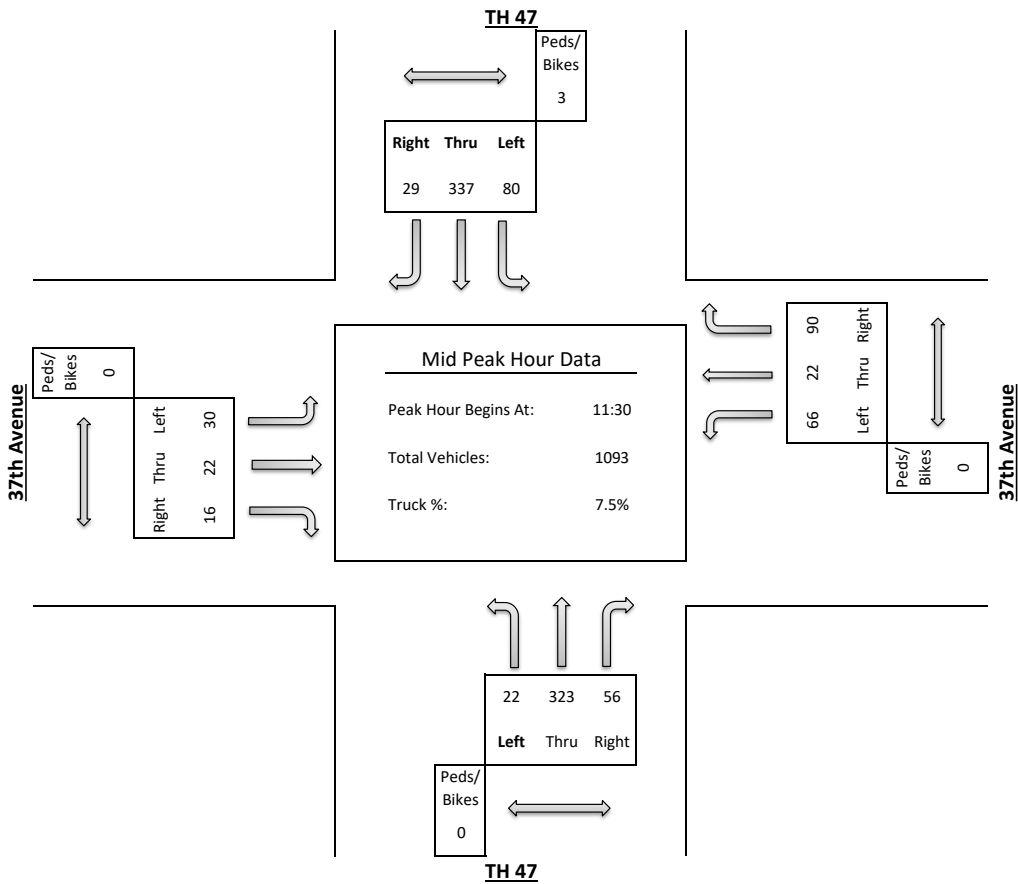

ALLIANT ENGINEERING, INC.

733 S Marquette Ave #700, Minneapolis, MN 55402

Intersection: TH 47 & 37th Avenue
 Date: 3/19/2024
 Duration: 0600-1800

Site Code: 601
 Ref Pt: N/A
 Page No: 4 of 4

All Vehicles (Cars & Trucks) Printed

Start Time	TH 47 Southbound						37th Avenue Westbound						TH 47 Northbound						37th Avenue Eastbound						Int. Veh. Total	Int. Ped/Bike Total
	U-Turn	Left	Thru	Right	App. Total	Peds/Bikes	U-Turn	Left	Thru	Right	App. Total	Peds/Bikes	U-Turn	Left	Thru	Right	App. Total	Peds/Bikes	U-Turn	Left	Thru	Right	App. Total	Peds/Bikes		
15:30	--	39	131	8	178	2	--	23	10	39	72	--	1	9	184	21	215	--	--	7	3	8	18	--	483	2
15:45	--	33	130	9	172	--	--	13	8	20	41	--	1	3	178	28	210	--	--	15	9	14	38	--	461	--
16:00	--	25	114	6	145	--	--	24	13	36	73	--	1	8	190	17	216	--	--	12	9	5	26	--	460	--
16:15	--	22	118	12	152	4	--	20	11	35	66	--	--	12	187	34	233	1	--	6	6	9	21	--	472	3
Hour Total	--	119	493	35	647	4	--	80	42	130	252	--	3	32	739	100	874	1	--	40	27	36	103	--	1876	5
% of App.	0.0%	18.4%	76.2%	5.4%			0.0%	31.7%	16.7%	51.6%			0.3%	3.7%	84.6%	11.4%			0.0%	38.8%	26.2%	35.0%				
% of Total	0.0%	6.3%	26.3%	1.9%	34.5%	80.0%	0.0%	4.3%	2.2%	6.9%	13.4%	0.0%	0.2%	1.7%	39.4%	5.3%	46.6%	20.0%	0.0%	2.1%	1.4%	1.9%	5.5%	0.0%		
Cars Total	--	114	472	32	618	3	--	73	38	124	235	--	3	31	725	98	857	1	--	36	26	34	96	--	1806	4
Cars % of Movement	0.0%	95.8%	95.7%	91.4%	95.5%	75.0%	0.0%	91.3%	90.5%	95.4%	93.3%	0.0%	100%	96.9%	98.1%	98.0%	98.1%	25.0%	0.0%	90.0%	96.3%	94.4%	93.2%	0.0%	96.3%	
Trucks Total	--	5	21	3	29	1	--	7	4	6	17	--	--	1	14	2	17	--	--	4	1	2	7	--	70	1
Trucks % of Movement	0.0%	4.2%	4.3%	8.6%	4.5%	#####	0.0%	8.8%	9.5%	4.6%	6.7%	0.0%	0.0%	3.1%	1.9%	2.0%	1.9%	0.0%	0.0%	10.0%	3.7%	5.6%	6.8%	0.0%	3.7%	

